

A Work Project, presented as part of the requirements for the Award of a Masters Degree in
Management from NOVA – School of Business and Economics

BUSINESS PROCESS REENGINEERING AT MERCEDES-BENZ

INÊS JORGE FIUZA MARQUES

2177

A Project carried out under the supervision of:
Átilla Vári

Budapest, 13th May 2016

Business Process Reengineering at Mercedes-Benz

Inês Jorge Fiuza Marques

Abstract

The main aspects of the Work Project will revolve around the business retail process of Mercedes-Benz Hungary. The main question to be answered was “How can Mercedes-Benz Hungary increase the sales consultants’ productivity and become number 1 in Hungary?” The methodology will clarify how the research to test the Business Project’s hypothesis was conducted: interviews, benchmarking and others. Subsequently, the results were developed in the form of sales process maps which were then analysed and recommendations provided. In the end, a small academic research on the luxury sector is provided as well as an individual reflection on the work done.

Keywords: Mercedes-Benz, Hungary, automotive, luxury

Table of Contents

Abstract	2
Brief Context	4
Reflection on the work done and individual contribution.....	7
Academic Review.....	21
Personal Reflection	26
References	28
Appendixes.....	30

Brief Context

The Consulting Report was conducted between Mercedes-Benz Hungária Kft. and a CEMS Consulting Team from Corvinus University of Budapest, composed of two international students and three home students. As for now, I will refer to Mercedes-Benz Hungária Kft. simply as Mercedes-Benz or Mercedes-Benz Hungary.

Our client, Mercedes-Benz, is the fastest growing premium automotive brand in Hungary. It is a 100% owned subsidiary of Daimler AG and functions as a wholesaler, distributing to 17 passenger car dealerships in Hungary. As for the scope of the project, we only focused on passenger cars and not vans, fleets or trucks.

In the Hungarian market, there are three large representatives in the premium automotive segment: Mercedes-Benz, Audi and BMW. Currently, Audi is in first place, with Mercedes-Benz in second place and BMW in third place. This ranking has been constantly changing in the past years. Mercedes-Benz has the goal to reach a steady first place by latest 2020. According to the Magyar Gépjármű Szövetség, which is the Hungarian Association of Car Manufacturers, in the whole 2015 car sales were 77.172, which represent a 14.4% increase from the previous year. This was the best result in terms of volume out of the last seven years. The overall market leader on 2015 was Opel, confirming the previous year position, followed by Skoda and Ford. Regarding the presence of premium brands on the list, we could find Audi in 12th place (2194 sales in 2015, representing an 8.9% variation and a share of 2.8%), BMW in 13th (2091 sales in 2015, representing a variation of 20.5% and a market share of 2.7%) followed by Mercedes-Benz in 14th (2044 sales in 2015, representing a variation of 36% and a 2.6% market share). All the brands are very close to each other, so the littlest fluctuations in the market will affect the ranking. In the first quarter of 2016, Mercedes-Benz surpassed BMW, reaching 2nd place in the ranking of the premium automotive segment. Regarding overall market, in the first quarter of 2016, the market leader

was Suzuki (with 2247 sales, representing a 86.8% increase), with a market share of 11.4%, outperforming Opel, former leader (sales of 2023 units, representing a 4.3% decrease) and Skoda (1888 sales, decreasing 14.6%). Just now in May 2016, there was a press release from Daimler where they announced an investment of €256M on the plant that Mercedes-Benz owns in Hungary. This project includes as well the development and expansion of the existing capacities. This plant increases the value of the Hungarian market, putting the plant as a “high-impact development”. In 2015 the plant in Kecskemét manufactured more than 180 000 compact cars in 2015. The four-door CLA coupé and CLA shooting brake are produced exclusively in this plant for export to the whole world.

According to preliminary interviews with our company representative and an evaluation of the wholesale organization, the main problem of the dealer network is the lack of productivity from the sales consultants. They spend extensive time with one single client and therefore the scope of our project was focused on finding reliable recommendations for Mercedes-Benz on tackling this issue. Most likely this is the reason restraining the company from reaching first place.

Following a Mercedes-Benz presentation, we could conclude that the usage of certain of the IT systems could be time consuming, leading to lower productivity of the sales consultants. This may result from the inappropriate usage or inadequate task distribution between the sales team’s members. Furthermore, there is saturation in the retail car market, which puts Mercedes-Benz in a position where it needs to innovate and to be ready for the upcoming challenges. Consequently, currently Mercedes-Benz offers several solutions, such as the *Mercedes me app*, the *Integrated Service Package* and *Driving Camp*. These services came to satisfy customer demand, however, the car retail market is always changing and products are continuously becoming more complex. Therefore, the company had to strengthen their business model, as well as to intensify customer care in order to maintain high level of

customer satisfaction. Regarding the client's perspective, they are looking for timesaving, for good service agreements and for smooth retail processes, which is what we will try to provide with our recommendations.

Despite not being the first in Hungary in terms of premium segment, Mercedes-Benz internal surveys measure an extremely high customer satisfaction index. However, it is not enough for their sales to rise and therefore Mercedes-Benz is looking for other ways to reach number one. One of their ideas is to launch new job positions, such as the *Product Expert* (it would function as an Apple Genius, offering high standard support, expertise and product experience, but not substitute the sales consultant), the *Star Assistant* (welcoming person) and the *Mobile Star* (delivery and test-drive hassle free, this person will take the car where the customer wants it, providing flexible individual care). The **Product Expert** is the one they are focusing the most efforts on and also where our team provided recommendations towards its entry in the Hungarian market.

Currently there are six positions in the dealerships' organizational structure: the general management, the sales manager, the sales consultant, the sales assistant, the used car manager and the after sales manager. The number of employees in these categories varies across dealerships and each of them gets their own tasks and responsibilities. Along our report, we made suggestions towards how these tasks could be switched or transferred in order to optimize the process. In the current context of the company, Mercedes-Benz knew some of the reasons why their process was not optimized. Not only the tasks were not appropriately distributed but there were also glitches with the IT systems used throughout the sale. Our company advisor mentioned issues such as duplication of data and a duplicated sales funnel (one sales funnel reporting to the dealerships' HQ and the other to Mercedes-Benz Hungary).

Our main challenge in the Business was to provide recommendations, which would lead to the optimization of the sales process. Mercedes-Benz is aware that the process is now time-consuming and that the sales consultants are not at their maximum productivity. Therefore, we had the task to suggest ways to increase this productivity, increasing the sales, in order to help Mercedes-Benz reach first place in the premium segment market. This position can only be reached when the process is optimized, which will drive more clients (either new or returning) to the dealerships and will allow the sales consultants to complete more sales in the same amount of time.

Reflection on the work done and individual contribution

Problem Definition

According to the information provided in the kick-off meeting at Mercedes-Benz, the sales process had to be optimized and changed in regards to time efficiency and ability to be easily adopted by the sales consultants. If the introduction of new job profiles and the changes in the IT systems are not implemented smoothly they will lead to inconvenience and complications in the process. The inefficient task delegation and the double entering of data in online systems may be currently extending the actual sale time. This results in the decrease of the number of sales conducted per week, hindering the sales consultants' ability to reach their target, or forcing them to work extra hours in order to do it. Mercedes-Benz believes that this process can be optimized and improved in order to make a better usage of the sales consultants' working hours.

The company seeks to become number 1 brand in the Hungarian premium automotive segment, based on sales value, surpassing Audi who is currently in this position. In order to achieve this, Mercedes-Benz has to increase the efficiency of the sales process, reached by increasing the sales consultants' productivity, throughout its various dealerships, while maintaining the currently outstanding customer satisfaction index (CSI). This can be done

through the acquisition of new customers or to reaching a high percentage of returning customers.

The main question our Business Project was answering was: ***How can Mercedes-Bens increase sales consultants' productivity and become No.1 in Hungary by latest 2020?***

Hypothesis & Methodology

In order to test our hypothesis and assess where the automotive retail process was not being efficient, we conducted research and process development. According to the preliminary meeting with Mercedes-Benz, together we identified that the lack of efficiency and productivity of the sales consultants came from absence of smoothness in the I.T. Systems, as well as, from the entering of duplicated data and ineffective allocation of tasks. In our methodology and analysis we tested if these were the real pain points, which were preventing the process from being optimized.

On a global approach, we divided the methodology in two steps: the information gathering and the process development. In order to gain the most efficient information for the report, we conducted two approaches for obtaining data: primary research and secondary research. The primary investigation was constituted by in-depth interviews (at two Pappas Auto dealerships, with the sales manager and sales consultants), as well as a secret shopping activity at the competitor's dealerships (to assess the *Product Genius* at BMW, which corresponds to the *Product Expert* that Mercedes wants to introduce). On the other hand, the secondary research passed by a competitor analysis and benchmarking with a focus on industry best practices and on the *Product Expert* position. This allowed us to enhance the reliability and validity of our results. The process development was divided into four stages: the visualization of the 9 steps in the high-level process map; the development of 'As-Is' maps with potential pain points; the reconstruction of the 'As-Is' maps based on different responsibilities and the creation of 'To-Be' maps.

On a deeper level of primary data collection, we conducted three interviews at different dealerships, where we contacted sales directors and sales consultants, both in the urban area of Budapest and in the countryside areas of Hungary. The first two interviews (in the capital) provided us a detailed picture about the operations of the dealership and about the relationship between Mercedes-Benz Hungary and Pappas Auto (where we conducted the interviews).

We received information on the current situation revolving around all the phases of the sales process and the areas for improvement. Moreover, as a retail consultant from Mercedes-Benz was present, we received insights on the job positions they want to develop. The discussion with the sales consultants allowed us to identify pain points and also assess the openness to change and the capability to adapt.

In the interview we conducted in the dealership on the countryside, we successfully discussed with the sales consultant the pain points in detail, as we already had a broader picture from the previous interviews. On the side, we kept developing and updating the sales process map, which would be our major deliverable in terms of analysis and recommendations. Further on, I will develop on this topic.

Besides the interviews, the primary research included a secret shopping activity. One of the team members visited a BMW dealership in the Budapest area, where he got a first-hand experience about the *BMW Genius* role, which is equivalent to Mercedes-Benz's *Product Expert*. This was an extremely valuable data collection as it allowed us to understand how such a position can work in a Hungarian context. Moreover, we could also assess flaws and areas of improvement in the BMW position, in order to provide better recommendations for Mercedes-Benz.

Regarding the secondary research, we focused on two main points: a proper competitor analysis and the understanding of the applied theory and charts. During the

competitor analysis, we focused on the industry best practices of the *Product Expert*. We conducted deep research on the competition, such as Audi and BMW, and also dig in Tesla to have a slightly different approach to the automotive retail process. Along the analysis, we focused on motivations of the companies and the employees and we gathered information from job openings, such as necessary background and career possibilities.

Regarding the theoretical material, mainly used to create the maps, we used the DMAIC – Six Sigma Method. This method allowed us to have a refined process, with quantifiable and sustainable results. We focused especially in the analysis face, where we developed swim-lane charts representing the process maps of the retail phases.

For the construction of the Sales Process Map, we based ourselves on the data collected during the interviews, as well as on the Automotive Sales Process Map of Mercedes-Benz Hungary, provided by our company advisor. Along the construction of the sales process map, we identified the pain points mentioned by the sales consultants, which allowed us to later provide recommendations for the optimization.

In order to efficiently visualize the differences between the current process map and the recommended one that we will construct with our suggested modifications, we used the “As-Is” and the “To-Be” Business Process Maps. The first contains all the currently existing phases of a typical business process model, as well as a list of roles, steps and exceptions. The “To-Be” process map developed afterwards displays the suggested changes and modifications, making them clear for the stakeholders.

For an accurate and easy visualization of these maps, we used Swim-Lane Charts, which visually distinguish job sharing and responsibilities of the various sub-processes of the business. This type of diagram makes responsibilities more clear and, as one of the recommendations regards the shift of tasks, it can describe the changes in a more efficient way.

Still regarding the methodology, we could identify delimitations and limitations to our project. Most importantly, it is important to state that we only focused our attention on the activity of Mercedes-Benz Hungary and therefore our findings will not be representative of the whole activity of Daimler A.G. Moreover, we only had interviews in one dealership group (Pappas Auto Magyarország Kft.), which makes our recommendations not valid for other Hungarian groups. Additionally, as a request from Mercedes-Benz, our efforts were drawn to the personal car business unit, not including fleets, buses, vans and trucks.

Analysis & Results

The beginning of our analysis involved the development of the sales process map. It was used as an overall tool for visualizing the complete actions a sales consultant goes through from the first contact with a client until the delivery of the final product. It is a high-level retail sales process map, including nine phases (and several sub-processes) connected to each other. We built this map with the information collected from the interviews, both at Mercedes-Benz with the company advisor but also at the dealerships. Below, the map can be found.

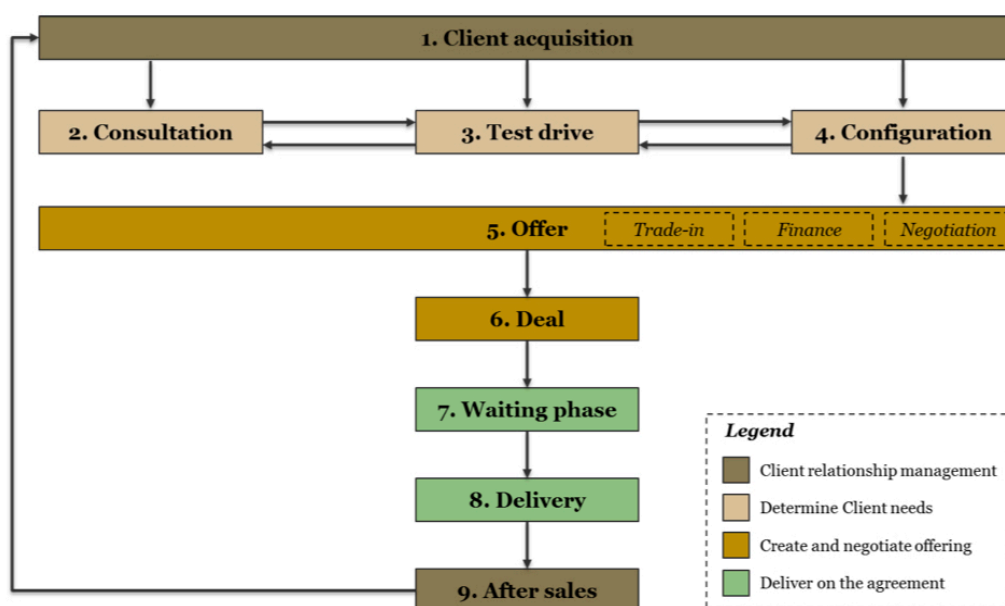

Figure 1: High-level retail sales process map of Mercedes-Benz Hungária Kft.

Now, it is important to detail a bit more each step, to allow comprehension of the process as well as a better understanding of the recommendations. It begins with client acquisition. This step represents the starting potential for consumer engagement and there are multiple channels of entry. The main two forms of customer contact are walk-ins or former customers from the dealership's database. If there is interest in buying a new vehicle then a meeting is set-up.

The following 3 steps correspond to the attendance of customer needs. The stage of consultation is especially crucial, as it will identify the exact details of what the client wants. This phase can run smoothly and quickly or it can take up additional time depending on two factors: the experience and expertise of the client and if they already have a model in mind or not. Once the model choice is narrowed to one, the sales consultant moves on to performing a test drive with the client. This phase requires preliminary administration work based on the client (especially in the case of a new contact). After the test drive, if the consumer is satisfied, they proceed to the step of configuration. If not, then they go back to consultation in order to choose another model for test drive that matches the client's preferences better. The configuration request can occur through different channels, online or offline: personal request, emails or standard website configuration. This stage can take more time, as the configuration needs to be on point regarding what the consumer wants, meaning several changes are bound to occur from the constant contact between the client and the consultant.

After the consumer has accepted a certain configuration, the duo proceeds to creating and negotiating offerings. Once the agreement is finalized, the sales consultant continues to the offering stage. It incorporates several sub-processes: trade-in, financing and negotiation. Trade-in enables the customer to trade their old car, abating on the new car's price. Financing requires back and forth communication with the finance department and the banks. In negotiation the client attempts for further discounts.

Once all the previous phases have been completed and accepted, the client can proceed to the deal phase. They have to sign compulsory documents and most likely wait for the production of the car (in rare occasions, the dealership may have it on stock, because it is a standard car or a service car, for instance). The latter represents the waiting phase and then the delivery happens. This is a big moment for the customer and should be emphasized as such. After the “celebration” of ownership, the sales consultant still has to perform internal system updates and administration tasks about the purchase, the consumer details and other necessary information.

In the following months and years to the purchase, the sales consultant has to keep on contact with the client, following up in his needs and wants. The after-sale is very important for customer satisfaction, as it makes the client feel supported and cared for. Moreover, it may lead to up-selling of other products/services or the purchase of a new Mercedes-Benz later on. The wholesale process can last between a few hours up to several days, depending primarily on the type of customer that the consultant is dealing with. They need to have the sensibility to identify the type of consumer type, catering their initial needs.

Moving on to the actual results we obtained from our analysis, we were able to identify six pain points hindering a smooth development. These placed different degrees of burden on the optimization of the sales process and on enabling the sales consultants to work on full potential. In the recommendations, we provided solutions to tackle these pain points.

The first pain point was identified in the Information/Consultation phase. The consultation can last for several hours in a scenario where the potential client enters the dealership with a high level of uncertainty. When this lack of sureness on needs and preferences happens, the consultants are compelled to provide detailed information on multiple models. In the worst-case scenario, this lagging process may not even lead to a purchase.

The second pain point we verified was during the configuration phase. According to data collected during the interviews, the sales consultants have to create numerous configurations for the same client, which leads to the creation of durational burdens. Many times, when consumers want to configure a new car, they don't even come to the dealership. Previous and experienced car buyers get in contact with the sales consultants with the expectation that they recall their taste based on prior purchases and configure the car accordingly, even if they are talking about a totally different model. This can lead to the need of several reconfigurations, which take a lot of time from the consultants. Another reason why this process is not optimized is due to the fact that the Mercedes-Benz website (which allows configurations) is not directly linked to the Global Ordering Systems. Therefore, the consultants have to introduce by hand the configuration in the Mercedes-Benz website and then on the GO system in order to be able to order the vehicle. This is a very slow and sluggish process, which leads to a burden in administrative tasks.

Regarding the next two pain points they were located in the offer phase. This stage incorporates a complex process, due to the sub processes involved. At this point we identified differences between the rural and the urban dealership. In the capital area, there is financial staff appointed to help the sales consultants keep in contact with the bank. Therefore, the sales consultants from Budapest have less administrative burdens with this task. However, the process still creates considerable lag times due to the constant need from banks to have all the confirmations and updated documents from buyers (and they require the information in multiple rounds and not all at once). Furthermore the bank's decision may take a long time. On the other hand, in the countryside, sales consultants do not get support on this issue. Therefore, they have higher burdens completing the financial process as well as having to personally fill out numerous documents needed for financing. This heavy administrative burden is taking up a lot of time from consultants, which could otherwise be used in

performing their actual work of completing sales. The other pain point within the offering phase was appointed at the trade-in sub-process. After the interview analysis, we only encountered this issue in the countryside dealerships. Due to less traffic, the dealerships could not afford to have a used-car manager. Therefore, it was the task of the sales consultants to deal simultaneously with the trading of used cars as well as with the selling of a new car. This involved several other administrative tasks, such as entering pictures and data of the old car into the used car market website, as well as further negotiations regarding it. In Budapest there was a specific division responsible for coping with trade-ins.

The fifth pain point in the research derived from the duplication in the sales funnel system. In the dealerships, the sales consultants had to deal with two sales funnel, one reporting to Pappas Auto HQ and the other one to Mercedes-Benz Hungary. Despite the two systems representing similar collections of data, the formulation and descriptions of particular data are different, creating an administrative burden. The differences in definitions in the two sales funnel lead to entering somehow different data into them, indicating that the data cannot be measured efficiently. Therefore, the probability of having incorrect results based on the sales funnels increases.

The sixth and final pain point we discovered drew on the abundance of administrative work delegated to the sales consultants. They have to fill out multiple sources of documents, such as general terms and agreements, data privacy statements, etc. throughout the whole process. These are needed documents, as they will ensure that a valid and legally binding contract is formulated. Again, we identified this pain point to be stronger in the countryside dealerships, where the sales consultants are expected to upload all the documents into the e-filing system. The burden emerged when we noticed that the e-filing incorporated multiple duplications of work. In a nutshell, consultants have to scan the documents, save them in the E-file, send them back to the manager and then they are still required to make an extra copy.

Additionally, they have to fill out the excel files with all the relevant data previously entered.

On top of all this, the sales consultants have to update a totally different excel file at the request of the sales managers in order to keep them informed about the contracts and deliveries.

Some of the burdens at dealerships are inevitable. There are obstacles that have to be encountered and surpassed, which limits the opportunity for a successfully optimized process. Also, we noticed that the location of the dealerships directly influence the complexity and burden of the pain points. However, the capabilities of the sales consultants and some of the pain points can be exploited optimally, in order to reach the highest productivity.

Recommendations

Relying on the information collected during the interviews, along with the secondary research data collected, we created a detailed “As-Is” and “To-Be” maps of the Mercedes-Benz Hungary sales process. These maps show the sequence of steps in the process, the interrelations between them as well as the actors responsible for these steps. For each phase, it was designed an “As-Is” and a “To-Be” process map, with the latter being created as an ideal future version of the current process (*due to confidentiality reasons, I will only show you the “As-Is” and “To-Be” charts for the Test-Drive phase, which can be found in appendix 1 and 2*). Based on these maps and on the pain points identified, the team compiled a list of recommendations to support Mercedes-Benz Hungary in reaching their goals and increasing the efficiency of the retail sales process.

First, Mercedes-Benz dealerships studied in this report should rearrange the sales-related tasks among employees in different positions, and/or should consider hiring new colleagues to perform these activities. This recommendation is directly linked to pain point one, three, four and six. As mentioned, rural and urban dealerships have different needs and complexities. Therefore, the specifics of the recommendation will be different for both types

of dealerships. For the ones with low showroom traffic (predominantly rural), we advised them to hire sales assistants who could relief some of the administrative burden put on the sales consultants. They would be well integrated and knowledgeable about the process in order to independently perform the required tasks (e.g. preparing and filling documents, updating sales funnels). On the other side, high traffic dealerships in the capital area are suggested to introduce the position of *Product Expert*. They would work together with the sales consultants, sharing some customer-related tasks, such as the acquisition of new prospects in the showroom and during special events (*Acquisition phase*) and providing assistance with the delivery (*Delivery phase*). Moreover, they would provide deeper and more technical knowledge as well as helping the consumer evaluates the different models during *Consultation and Information stage*. However, it is key to understand that they would not make the sale; they would just be a support to the sales consultant. Based on the benchmarking studies we conducted, we propose this position to be for younger and outgoing individuals, with a high interest in cars and Mercedes-Benz. They don't necessarily need to have engineering or automotive background, as Mercedes-Benz will provide deep training. What is necessary is passion and being good at clarifying complex things in an easy way. Regarding remuneration, we suggest a fixed salary and possibly a bonus based on the number of new customers acquired or test-drives conducted. As they would not be performing sales activities, they would have to dress differently from the sales consultants. We suggested smart casual instead of business formal. A lower burden on the sales consultants, more time to spend with the clients and more efficient reporting would result from these recommendations. Summarizing, mostly administrative tasks would be eliminated from the consultants' agenda in rural dealerships and customer-related, but non-core and highly time-consuming tasks, would be eliminated in the Budapest dealerships.

As our second recommendation, we suggest the creation of an interface between the car configurator of the central website and the GO system used for creating official configurations and offers towards the consumers. As an ideal solution for pain point two, it would require the sales consultant to type one code from the website as an input and the GO system would automatically obtain the individual specifications codes, creating the configuration. Furthermore, it would create an appealing offer document, which automatically would fill in the data from the configuration, only requiring manual input regarding the SNL discounts and additional details. The interface would as well automatically update the sales funnel and CRM systems. This recommendation would decrease the time spent by the sales consultant creating multiple configurations and boost the consumer satisfaction by decreasing waiting time on waiting for an official offer and providing a visual experience.

Thirdly, we suggest Mercedes-Benz to aim at the standardization of the reporting systems (i.e., sales funnels) across its dealerships. The sales funnels should be compared across definitions to reach a common understanding of the terms (“configuration” and “offer”, e.g.). Afterwards, data introduction into the two funnels should be unified, avoiding double administrative work. In the long term, automation between the report system, the CRM system and the GO system will be ideal, providing two main benefits: increase of productive time and better data quality. Furthermore, this recommendation would implement best practice system across Hungarian dealerships, with expected results of a lower reporting burden, more reliable data and better functioning sales incentives system.

Next, we advise Mercedes-Benz to minimize redundancies between all systems used in different dealerships. We divided the recommendation in three actions. The AS400 should be phased out. The functionality of the new systems should be developed to make them valuable and used friendly (e.g. development of a link between the GO and the dealership’s CRM). Finally, the required documents from the sales consultants should be standardized

across all the dealerships, avoiding administration tasks aimed at the same target and data (e.g. no separate contract should be asked by the managers except the one which is already available in the systems). Solving these redundancies would lead to lower administrative time spent by the sales consultants, as they would only have to update the general systems.

Finally, all dealerships should have a proper, separate delivery site. This is the most important step on the customer journey, and can greatly modify the experience. A separate decorated room can provide the appreciate privacy, while the design will make the memory of the consumer extremely better.

Besides the above recommendations, we have also suggested small process improvement recommendations, helping to further increase the efficiency of the sales process (e.g. more regular data update in the systems). Using the detailed process maps in junction with the suggestions, Mercedes-Benz Hungary can take further steps in having a top-of-class sales system of the premium automotive segment, increasing the efficiency of the sales team and maintaining the high CSI by delivering outstanding customer experience.

Concerns towards Implementation

While suggesting the recommendations, some concerns regarding implementations issues came to our mind. However, we do think that the outcomes, which will come out from the suggestions, will overpower any possible issue that could have arose in the implementation stage.

There can be some shortcomings regarding the extra costs for HR on hiring sales assistants and product experts. However, the dealerships do need the extra people and should understand that hiring the new colleagues will lead to higher sales and therefore higher revenues for the dealership. Moreover, issues related to the lack of compliance by both parts regarding the standardization/sharing of the I.T. systems can also rise. Dealerships may feel a lack of privacy or issues related to other car brands they may sell, as the dealerships are not

exclusive, but selective. Also, we only studied Pappas Auto, therefore we don't know until which point is the Mercedes-Benz system compatible with the other dealerships'. Hence, it would be important to study all the partner dealerships and respective systems in order to confirm that this change would be better for all.

Another shortcoming that may rise at the implementation stage is the resistance to change of the dealership's employees. A change is rarely easy and it has to be well explained how it will help the company and why is it needed. Moreover, there may be a lack of technological expertise, especially in the rural dealerships, which will require training. Otherwise, the new systems could bring another burden instead of smoothing the process. From the interviews we conducted and the analysis we performed, we could assess that the companies are ready for these changes and are willing to perform them. As soon as they see the added value in the recommendations, both the dealerships and Mercedes-Benz will be open to implement changes that will allow them to reach their objectives.

Individual Contribution

For the Business Project we worked really well as a group. All of us were involved in all the project phases, especially at the beginning in the interviews and research. Specifically in the secondary research, I was responsible for the competitor analysis and benchmarking. It was challenging and though at times to retrieve all the information, due to the fact that English is not so widely present in Hungary, especially not in the automotive sector. However, little by little I found the articles and the studies necessary in order to present an accurate competition analysis (also with the help of the Hungarian teammates and Google Translate). It was interesting as we did some benchmarking with other countries that have the *Product Expert* position. It was curious to see how such a position could work in the automotive sector, without taking the smoothness out of the process or shadowing too much

the sales consultant. Therefore, this was a crucial part of our research in order to provide the best recommendations.

Regarding the interviews, I was involved in the development of the guidelines and also a part of the analysis. Concerning the last part all the students in the team were involved in the analysis of a certain interview, and we all completed each other's work. Each interview guideline had to be adapted after the previous interview, especially due to changes in the agenda or questions that were already answered or left unanswered. About the report writing, I was responsible for the whole introduction part. I had to introduce the company, the context, the problem definition and formulation as well as to give a deeper understanding on the I.T. systems and the organizational structure of the company. It included a lot of research, which was necessary to provide the most complete information. Additionally, I was involved in the development of the maps and the recommendations. This was a more creative part of the report, which also required brainstorming and strategic thinking on what would work best. Everyone provided insights on what we thought would work or not and it was very stimulating to be involved in this process.

Academic Review

For the academic review, I am going to study luxury branding theories. It is a topic that can be related to the BP as Mercedes-Benz can be considered a premium to luxury automotive brand. Therefore some of the to be studied theories will apply to the company at stake.

According to BCG's Projections in 2014, the global market for luxury goods and services was at €1.4 Trillion. Per category, luxury goods represented €680 billions, while experiential luxury stood for €720 billion. The luxury market is growing, with the highest perspectives in the BRIC countries (Kapferer, 2008). The number of rich people is constantly increasing, enlarging the gap between extraordinary and ordinary people (Forbes, Feb. 2010).

The phenomenon of the democratization of luxury is happening. Due to economic growth after the crisis, the middle class feels optimistic and wants to trade-up and the need to belong and show off is leading this market to grow, directly correlated to GDP growth (Kapferer, 2008). According to The BCG's Estimates in 2012, the growth of experiential luxury was between 27%-28%, while the growth for personal luxury goods was at 19%-22%, in the BRIC countries. Europe, U.S. and Japan, the growth rates stood at an average of 6%. It is therefore clear where the market is growing more exponentially. This is a point where the market has to be careful, as the loss of exclusivity is a major threat for luxury brands.

There is no commonly agreed definition of what is luxury, and the concepts are still very blurry (Kapferer, 2001, p.319). According to Bain & co., "traditionally the word luxury applies to tangible goods, suggesting superior materials and designs sold in an upscale retail environment". On the traditional definition, luxury relies on beauty and aesthetic excellence, craftsmanship and precious and rare materials. There is physical rarity of qualified labour and material, luxury becomes multisensory and must have human content/origin. On the other hand, according to T. Jackson (*citation*), luxury means "exclusivity, premium prices, image and status which combine to make them more desirable reasons other than function". Absolute luxury brings a consensus among the authorities. It represents the categories and famous brands, which are held in the world as symbols of luxury (Kapferer, 2008). Whereas in the past luxury represented aristocracy, etiquette, and inherited rank; it now represents meritocracy, reward by success and access to elite pleasures (Kapferer, 1996). According to J-N. Kapferer's early approach, luxury could be defined as a distance, expressing the gap between desire and access. The greater the inaccessibility, the greater the desire, turning luxury into a relative concept (Kapferer, 1996). In this definition, luxury should be highly visible (many people desire), but artificially rare (not many can access it). This leads to the theoretical dream equation: the desirability of a luxury brand is correlated with the difference

between brand awareness and brand penetration (Dubois & Paternault, 1994). In a more recent approach, luxury can also be defined as the creator's light, where the brand expresses the *aura* (light) of the creator (Kapferer & Bastien, 2012; Dion & Arnould, 2011). In this theory, luxury represents the charismatic legitimacy based on an exceptionally charismatic persona, which can be the brand founder (Armani and Giorgio Armani for example) or the artistic director who designs the products (Galliano for Dior, until 2013). The brand is fully involved in this *aura*, from the *griffe* (art, pure creation) on top of the pyramid, passing by luxury products (small series, handmade) and upper-range products (limited production, selective distribution) until it reaches the accessories and licensed products, which are represented in a wider but still selective distribution. In order to feed the dream, brands apply a strong sales strategy to the wider market in the bottom of the pyramid in order to provide investment to nourish the "myth" around the brand. The charismatic authority has to be legitimized in order to legitimize the aura, through authorities in the domain and has to be confirmed periodically, to avoid the risk of evaporation. Fashion shows are the most important collective ritual for luxury brands (Dion & Arnould, 2011), tackling this issue.

Luxury is aspirational and the mass wants to have a little of what it symbolizes. It elevates them, it gives them pleasure, beauty and style, it gives them meaning, high quality, out of the ordinary products and social distinction. Luxury at its best will deliver a rare intense emotion (Kapferer, 2008). Contrastingly, luxury is also in danger. With the middle class growth in many countries, there is a business opportunity for the mass brands to mimic luxury codes and capture the demand (Kapferer, 2008). Therefore, luxury brands have to be careful not to run after this demand, which would mean running after volume and losing exclusivity.

If the luxury consumer is not educated it may be confused with the brands in the market, as main street brands are imitating high streets brands, and the frontiers are becoming

more and more unclear (Kapferer, 2008). This is happening because mainstream brands are using the codes of luxury, such as small limited series, top models, and well-designed stores, for instance. Moreover, a lot of terms, such as mass luxury, premiumization, mass prestige (“masstige”) and new luxury are showing up, increasing even more the confusion in the mass-market consumers. Most luxury brands refrain from explicitly calling themselves luxury, and are at the same selling more and more products from the first tiers of the pyramid such as sunglasses. Additionally, more and more non-luxury brands are selling “masstige” products, providing their customers with a little feel of luxury (Silverstein & Fiske, 2003, p.50; Truong, McColl and Kitchen, 2009, p. 376). These “masstige” products in the mass market reduce the level of rarity achieved through reasonable prices, which requires a compromise on quality, exclusivity and aesthetics (Keller, 2009, p.295).

Luxury brands have then the challenge to preserve the image of exclusivity (Keller 2009, p.292). This is why many brands are selling line extensions, which are aimed to the mass market, positioned in the lower levels of the product pyramid. For instance, Ferrari has mass-market stores where they sell watches, apparel, computer cases and all this diverse products, which categories do not compete with their core product. Ferrari cars still remain exclusive and expensive however they are exploiting the value of the brand by offering products in these diverse categories sold to the masses (Berthon et al. 2009, p. 54).

Another topic that rose confusion is the luxury or premium discussion. In the car sector, brands such as Audi, BMW and Mercedes-Benz are located in the premium sector, whereas Porsche, Lamborghini and Ferrari, for instance, are in the luxury sector. What differentiates them is the lower price for a high quality (Kapferer, 2008). They are less exclusive and are at the reach of a medium-high class. However, they position themselves as luxury, which generates confusion on the non-educated consumer. Luxury however is not simply a higher price than premium. It represents two indissociable faces: a sociological face,

incarnating social stratification, and a psychological face, giving the client pleasure and the dream of exception (Kapferer, 2008). For economists, luxury provides less functional benefits than premium. It brings more emotional benefits and status, rather than being useful and practical. Luxury gets closer to art (Kapferer, 2008), cultivating them and having them present in their collections, campaigns, runway shows and stores.

An interesting topic to study would be the presence of the brands online. Until which point would it be interesting and valuable for the brands to provide an online shop to their consumers? Wouldn't it take out part of the experience? Burberry, for instance, has been selling twice as much online than offline (HBR, 2013), however this may mean that there is intensification in distribution methods and it is giving the access to the wider public. Brands have to be careful in order not to fall into the generalization of luxury (as mentioned), by changing to mechanized products and a sales strategy focused on non-core product lines, which reach a wider public. Regarding a critical thinking towards luxury brands and the branding strategies, I do believe it is hard for them to maintain the exclusivity, while reaching the mass market in terms of visibility. Moreover, they need to have a share to sell to the mass market in order to have the investment to feed the dream. Especially as there is no specific definition of luxury, consensual among all the authorities, the research further on luxury topics becomes harder. After all, what is luxury? It is a relative term, which changes for each person but the same person can perceive luxury differently in different contexts or stages of their lives. For instance, while Volkswagen Golf can be seen as a luxury car to a student of university loans, a Mercedes-Benz S-Class can be seen as an ordinary car to a wealthy businessman. Luxury now has become an extremely used and exhausted label for almost anything (Berry, 1994, p.3; Vickers & Renaud, 2003, p.460).

This is the reason why I find luxury marketing and management so interesting. The brands have to feed the exclusivity, have to give people the sense of belonging and being

special, without committing the mistake of becoming ordinary. Luxury is the dream; it gives social elevation and self-distinction. It is art, priceless, hedonism and superlative.

Personal Reflection

The Business Project was a very productive and interesting learning process. I learnt a lot from my peers and from the company, as well as from the company and the sector. It was an industry where my insights were quite low, so it was challenging, especially in the beginning, but also very rewarding. Teamwork was definitely the skill I found to be more preeminent in me. Some of the group members did not trust as much in the group and were more individualistic. As such, we had to apply a working method, which would suit everyone. I definitely learnt a lot about working with different people, and I had to change sometimes my way of thinking in the benefit of obtaining the best results. In the end everything turned out for the best.

Moreover, from the BP work, I could see that I am a very organized person that likes to have things done on time and accurately. Sometimes this can turn out to make me somehow “pushy” or “bossy”. However, I think I reached a balance without being “too much” but still showing my point when things needed to be done, and well done. There were some situations in the group when things were not going so well, especially when some group members were busier with other tasks and leaving the BP behind because it was “not so important”. Then, I would take over their parts, as I also understood that I couldn’t see things undone or unfinished just hanging around. However, everything was solved after a small conversation with the members in question, explaining them that we had put a lot of effort in this already and that we all had other things to do but this was also our responsibility and our task.

I pay attention to detail but I am not a perfectionist. I understood across this BP work that this a point which I can improve. It is crucial to pay special attention to detail, to look at

each little thing and investigate it. Especially while studying interviews, everything is important and not just what the interviewee is saying. Corporal language or changes in tone, for instance, have to be studied with a different look and a special touch and sensibility. I believe this is still an area where I can improve and develop for further projects. In the team, I took the role of moderator, keeping in touch with all the team members and assuring that everyone was in agreement. When doing a group project it is important to be all in the same pace, especially when we are working separately. Moreover, I also moderated arguments that could arise, in order to avoid conflicts in the team and the creation of a smooth, friendly environment. I took this role because I have a very stable person. I am as well a very good listener and I understand different points of view. Moreover, I tend to avoid conflicts, but still believe that arguments in a discussion are productive. Along the BP I also developed my learning on the automotive sector but also on the consumer approaches and the retail processes. It was interesting to see how the company operated from within, the system they used and their methods. Moreover, I also learnt how to develop swim-lane charts and the different uses for them. I believe they will be useful in the future, especially if I seek a function in process management or operations management. Overall, the whole business project was a learning curve. Not just was I working with people from different cultures (Hungarians and Danish), as well as with a topic on which I had no background. However, in the end, it made me grow and be more open minded and culturally aware.

References

- Autotrader. 2014. "Car Buyer of the Future". Source: Márton Mattusich, Provided: 22.02.2016
- Berry, C.J. 1994. *The idea of luxury – a conceptual framework and historical investigation*. Cambridge: Cambridge University Press
- Berthon, P. et al. 2009. "Aesthetics and Ephemerality: Observing and Preserving the Luxury Brand". *California Management Review*. Vol 52. Pp 45-70
- BMW Careers. 2016. "Start Your BMW Career As A BMW Genius".
- Chambers, N. 2011. "Tesla is Turning the Car Sales Model on Its Head". *Autotrader*
- Dion, D. and Arnould, E. 2011. "Retail Luxury Strategy: Assembling Charisma through Art and Magic". *Journal of Retailing*.
- Dubois, B and Paternault, C. 1994. "Le luxe en Europe: Demande comparable mais visions contrastées". *Communication Business News*
- Elberse, A., 2015. "Burberry in 2014". *Harvard Business Review*
- Gallo, C. 2014. "BMW Radically Rethinks The Car Buying Experience". *Forbes*
- GoLeansixsigma. 2012. "DMAIC: The 5 Phases of Lean Six Sigma". Source: Márton Mattusich. Provided: 22.02.2016
- Heine, K. 2012. "The concept of luxury brands"
- Kapferer J-N. 2008. *The new strategic brand management*. London: Kogan Page
- Kapferer, J-N and Bastien, V. 2009, "The specificity of luxury management: turning marketing upside down". *Journal of Brand Management*. Vol. 16, no. 5-6.
- Kapferer, J-N and Bastien, V. 2009. *The luxury strategy (break the rules of marketing to build luxury brands)*. London: Kogan Page
- Keller, K.L. 2009. "Managing the growth trade-off: challenges and opportunities in luxury branding". *Journal of Brand Management*. Vol. 16. Pp 290-300

Mainka, J. 2014. “‘I have far the best team’ – Interview with Ingo Fröhlich, General Manager of Mercedes-Benz Hungária Kft.”. <http://budapesttimes.hu/2014/05/09/i-have-by-far-the-best-team/>. (accessed: 20.04.2016)

Mainka, J. 2015. “‘We are very satisfied with the local conditions’ – Interview with Reinhard Leutgeb, Managing Director of Pappas Auto Magyarország Kft.”. <http://budapesttimes.hu/2015/07/10/we-are-very-satisfied-with-the-local-conditions/> (accessed: 20.04.2016)

Roland Berger. 2015. *Automotive Insights*.

Silverstein, MJ and Fiske, N. 2003. “Luxury for the masses”. *Harvard Business Review*

Tesla Careers. 2015. “Product Specialist Description”.

The Economist. 2015. “The Motor Trade: Death of a car salesman”. August 22, 1-5.

Truon, Y., McColl, R. and Kitchen, P.J. 2009. “New luxury brand positioning and the emergence of masstige brands. *Journal of Brand Management*. Vol. 16. Pp 370-380

Verity Partners LLC. 2016. *Automotive Dealer Virtual Sales, Marketing and Technology*.

Vickers, J.S. and Renand, F. 2003. “The marketing of luxury goods: an exploratory study – three conceptual dimensions. *The Marketing Review*. Vol 3. Pp 460-478

Appendixes

Appendix 1: Test-drive phase – “As-Is” map

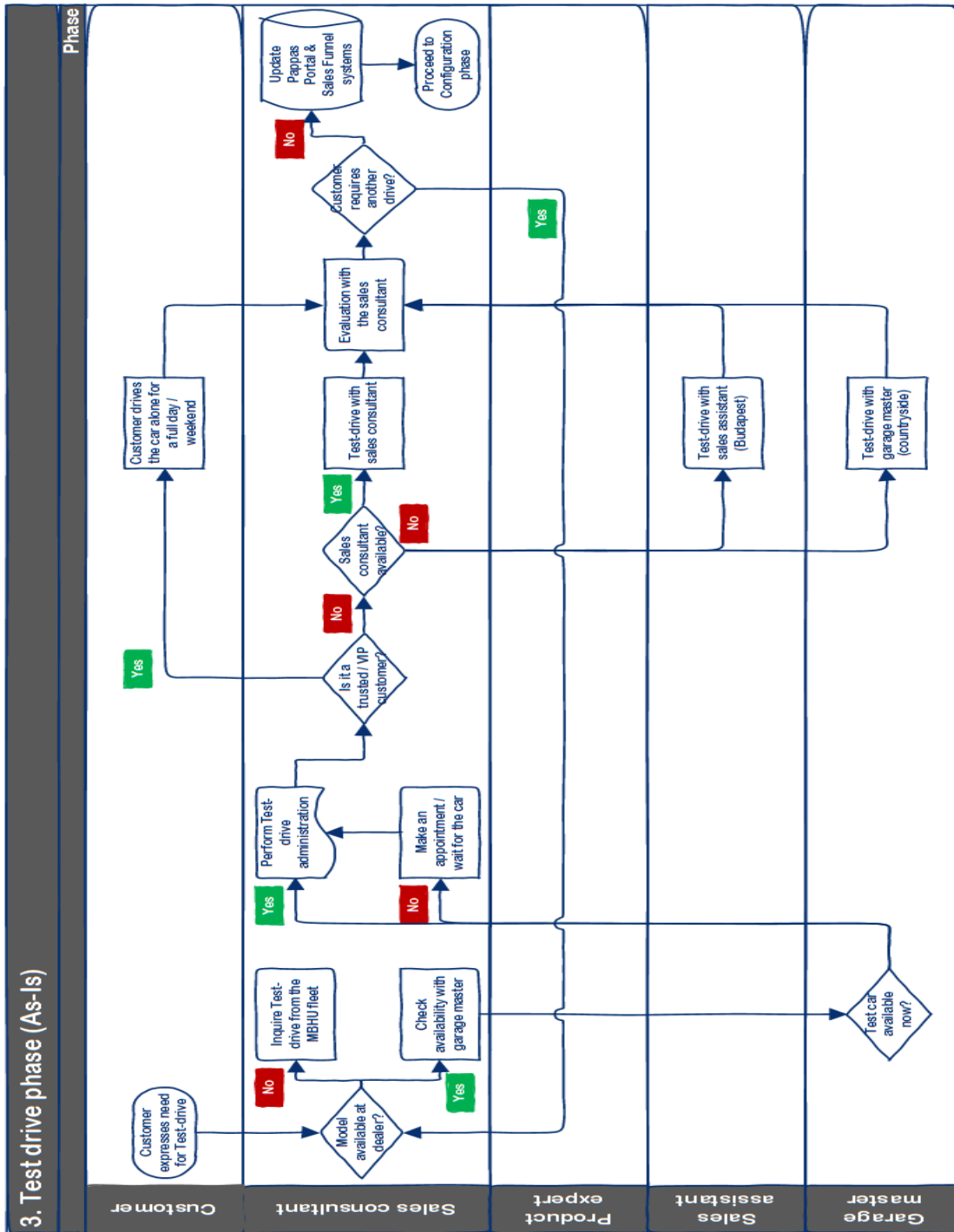

Appendix 2: Test-drive phase – “To-Be” map

