



**Cátia Marisa Pereira Marques**

Licenciatura em Biologia

**Concentration of Beverages by Osmotic  
Evaporation: Effect on Organoleptic  
Properties and Antioxidant Activity**

Dissertação para obtenção do Grau de Mestre em  
Biotecnologia

Orientador: Isabel Maria Rôla Coelho, Prof. Auxiliar,  
FCT/UNL

Co-orientador: Vítor Manuel Delgado Alves, Prof.  
Auxiliar, ISA/ULisboa

Júri:

Presidente: Prof. Doutora Ana Cecília Afonso Roque  
Arguente: Prof. Doutora Carla Maria Carvalho Gil Brazinha de Barros Ferreira  
Vogal: Prof. Doutora Isabel maria Rôla Coelho



FACULDADE DE  
CIÊNCIAS E TECNOLOGIA  
UNIVERSIDADE NOVA DE LISBOA

**Outubro, 2014**





**Cátia Marisa Pereira Marques**

Licenciatura em Biologia

**Concentration of Beverages by Osmotic  
Evaporation: Effect on Organoleptic  
Properties and Antioxidant Activity**

Dissertação para obtenção do Grau de Mestre em  
Biotecnologia

Orientador: Isabel Maria Rôla Coelho, Prof. Auxiliar,  
FCT/UNL

Co-orientador: Vítor Manuel Delgado Alves, Prof.  
Auxiliar, ISA/ULisboa

Júri:

Presidente: Prof. Doutora Ana Cecília Afonso Roque  
Arguente: Prof. Doutora Carla Maria Carvalho Gil Brazinha de Barros Ferreira  
Vogal: Prof. Doutora Isabel maria Rôla Coelho



FACULDADE DE  
CIÊNCIAS E TECNOLOGIA  
UNIVERSIDADE NOVA DE LISBOA

**Outubro, 2014**



## **Concentration of Beverages by Osmotic Evaporation: Effect on Organoleptic Properties and Antioxidant Activity**

Copyright © 2014 – Cátia Marisa Pereira Marques, Faculdade de Ciências e Tecnologia, Universidade Nova de Lisboa

A Faculdade de Ciências e Tecnologia e a Universidade Nova de Lisboa têm o direito, perpétuo e sem limites geográficos, de arquivar e publicar esta dissertação através de exemplares impressos reproduzidos em papel ou de forma digital ou por qualquer outro meio conhecido ou que venha a ser inventado, e de a divulgar através de repositórios científicos e de admitir a sua cópia e distribuição com objetivos educacionais ou de investigação, não comerciais, desde que seja dado crédito ao autor e editor.



À minha família, que são para mim o mundo.



That which is impenetrable to us really exists. Behind the secrets of nature remains something subtle, intangible, and inexplicable. Veneration for this force beyond anything that we can comprehend is my religion.

— Albert Einstein



## Agradecimentos

---

Este trabalho é o resultado de escolhas conscientes e espírito de descoberta e foi sem dúvida um ano de desafios, novas aprendizagens e de desenvolvimento pessoal. Atingida esta etapa não poderia deixar de agradecer às pessoas que o tornaram possível. Assim deixo o meu profundo agradecimento:

À minha Orientadora, Professora Doutora Isabel Coelho por me ter dado a oportunidade de realizar este trabalho. Pela disponibilidade demonstrada e confiança nas minhas capacidades, pelo empenho que demonstrou no trabalho em curso ao longo deste ano, motivando-me sempre a alargar os meus conhecimentos na área em estudo.

Ao meu Co-orientador, Professor Doutor Vítor Alves pela disponibilidade, boa disposição e clareza. Ajudando-me em todos os passos e criticando o meu trabalho nos momentos mais necessários.

À forma como Orientadora e Co-orientador funcionaram em equipa procurando sempre o melhor para este projeto. Sem eles este trabalho não seria possível e por este motivo lhes estou muito grata.

À Rita Ferreira, que foi uma pessoa fundamental para este projeto, mas acima de tudo para a forma como trabalho em laboratório e como me sinto no papel de investigadora, uma vez que me ensinou todas as ferramentas para realizar um trabalho profissional. Neste contexto agradeço também à Carla Martins, pela disponibilidade para ajudar sempre que necessário, procurando sempre ensinar-me o melhor modo de fazer as coisas.

À Florina por acreditar tanto em mim e por estar sempre disponível para melhorar o meu dia.

A todos os colegas com os quais partilhei o laboratório, tanto na FCT como no ISA (Marta Neta, Andreia Medeiros, Carina Manjua, Hugo Andrade, Flávia Ribeiro, Patrícia Fradinho, Vanessa Batista, Daniela Silva e Daniel Duarte) que me proporcionaram bons momentos e facilitaram os momentos mais complicados.

Aos meus amigos e familiares que acompanharam a minha jornada e me incentivaram a dar sempre o melhor de mim.

Aos meus pais, Rui e Olinda, Mano Pedro, Mana Rita, avós Tomaz e Quitéria e ao meu Alexandre por darem tudo deles e aceitarem tudo de mim, e por fazerem de mim a pessoa que sou hoje, por me amarem e por me compreenderem. O vosso apoio é o meu pilar!



## Resumo

---

A concentração de bebidas tem grande interesse, uma vez que permite a redução dos custos de transporte, armazenamento e embalagem, da mesma forma permite o aumento do tempo de vida dos produtos, originado pela superior resistência à atividade microbiana.

Os processos com membranas têm vindo a ser propostos para a concentração de bebidas como alternativas promissoras ao processo tradicional de concentração devido às moderadas condições de operação. Neste estudo foi usado o processo de evaporação osmótica com o objetivo de concentrar três diferentes chás e sumo de laranja natural, bem como avaliar o efeito deste processo nas propriedades organoléticas e atividade antioxidante.

O processo de concentração foi levado a cabo num contactor de membrana de fibras ocas. A bebida foi circulada na carcaça do contactor e a solução osmótica concentrada ( $\text{CaCl}_2$  5M) foi circulada no interior das fibras. O fluxo, força motriz e coeficiente de transferência de massa foram avaliados durante o tempo do processo. Todas as bebidas foram concentradas pelo menos três vezes.

As bebidas concentradas foram analisadas em termos da sua atividade antioxidante (métodos DPPH e FRAP), conteúdo de fenólicos totais (método Folin-Ciocalteu) e cor. A concentração de ácido ascórbico foi medida para o sumo de laranja pelo método 2,6 - diclorofenolindofenol – extração com xileno.

Os resultados indicam que a atividade antioxidante e o conteúdo de fenólicos totais permaneceu constante durante as primeiras seis horas do processo de concentração, após as quais foi registado o seu decréscimo. Foram observadas alterações na cor das bebidas após o processo de concentração ( $7,11 < \Delta E^*_{i,F} < 24,32$ ). O conteúdo de ácido ascórbico decresceu 32,7% durante o processo de concentração. Contudo, estes resultados não são uma limitação, uma vez que este pode ser operado num menor tempo, usando contactores de membrana com maiores áreas de contacto.

*Palavras-chave:* evaporação osmótica; contactores de membrana; concentração de bebidas; atividade antioxidante; conteúdo fenólico; ácido ascórbico.



## Abstract

---

The concentration of beverages has a great interest because it enables lowering the transportation, storage and packaging costs, as well as the increase of product's shelf life originated by its higher resistance to microbial activity.

Membrane processes have been proposed for beverages' concentration as promising alternatives to the traditional concentration processes due to the mild operating conditions. In this work, the osmotic evaporation membrane process was used in order to concentrate three different teas and fresh orange juice, as well as evaluating the effect of this process on the organoleptic properties and antioxidant activity.

The concentration process was carried out in a hollow fibre membrane contactor. The beverage was circulated through the shell side of the contactor and a concentrated osmotic solution (CaCl<sub>2</sub> 5M) was circulated inside the fibres. The flux, the driving force and the mass transfer coefficient were evaluated during the process time. All beverages were concentrated at least three times.

The concentrated beverages were analysed in terms of their antioxidant activity (DPPH and FRAP methods), total phenolic content (Folin-Ciocalteu method) and colour. Ascorbic acid concentration was measured for the orange juice by 2,6 - dichlorophenolindophenol - xylene extraction method.

The results indicate that the antioxidant activity and total phenolic content remains constant during the first six hours of the concentration process, after which a decrease was noticed. Alterations in the beverages colour after the concentration process ( $7.11 < \Delta E^*_{i,F} < 24.32$ ) were observed. The content of ascorbic acid decreases 32.7% during the concentration process. However, these results are not a limitation since the process can be operated in a shorter time, using membrane contactors with higher contact areas.

*Keywords:* osmotic evaporation; membrane contactors; beverage concentration; antioxidant activity; phenolic content; ascorbic acid.



# Contents

---

<b>Chapter 1 Thesis Introduction .....</b>	<b>- 1 -</b>
1.1 Background and Motivation .....	- 3 -
1.2 Objectives and Thesis outline .....	- 6 -
1.3 References.....	- 7 -
<b>Chapter 2 Optimization of the operating conditions in OE .....</b>	<b>- 9 -</b>
2.1 Introduction .....	- 11 -
2.2 Experimental .....	- 21 -
2.2.1 Osmotic Evaporation unit and procedures .....	- 21 -
2.3 Results and Discussion.....	- 23 -
2.3.1 Optimization of hydrodynamic conditions on the fibres .....	- 23 -
2.3.2 Optimization of hydrodynamic conditions in the shell side of the module .....	- 24 -
2.3.3 Mass transfer correlations .....	- 25 -
2.3.3.1 Fibres mass transfer correlation .....	- 25 -
2.3.3.2 Shell side mass transfer correlation .....	- 26 -
2.4 Intercalary Remarks.....	- 27 -
2.5 References.....	- 28 -
<b>Chapter 3 Study of Teas Concentration Process.....</b>	<b>- 31 -</b>
3.1 Introduction .....	- 33 -
3.2 Experimental .....	- 35 -
3.2.1 Extraction process of teas .....	- 35 -
3.2.2 Concentration process by OE .....	- 35 -
3.2.3 Total Solids determination.....	- 35 -
3.2.4 Total phenolic content .....	- 36 -
3.2.5 Antioxidant Activity .....	- 36 -
3.2.6 Colour analysis.....	- 37 -
3.3 Results and Discussion.....	- 38 -
3.3.1 Concentration process by OE .....	- 38 -
3.3.2 Evaluation of teas concentration .....	- 40 -
3.3.3 Antioxidant activity and phenolic content .....	- 42 -
3.3.3.1 Total phenolic content .....	- 42 -
3.3.3.2 Antioxidant activity.....	- 43 -
3.3.3.3 Relation between antioxidant activity and total phenol content.....	- 44 -
3.3.4 Colour analysis.....	- 46 -

3.4 Intercalary Remarks.....	- 47 -
3.5 References.....	- 48 -
<b>Chapter 4 Study of Orange juice Concentration Process .....</b>	<b>- 51 -</b>
4.1 Introduction .....	- 53 -
4.2 Experimental .....	- 56 -
4.2.1 Preparation of the orange juice .....	- 56 -
4.2.2 Concentration process by OE.....	- 56 -
4.2.3 Total phenolic and ascorbic acid content.....	- 57 -
4.2.4 Antioxidant Activity .....	- 57 -
4.2.5 Viscosity measurement .....	- 57 -
4.2.6 Colour analysis.....	- 57 -
4.3 Results and Discussion.....	- 59 -
4.3.1 Evaluation of the concentration process by OE .....	- 59 -
4.3.3 Antioxidant Activity .....	- 62 -
4.3.3.1 Total phenolic content .....	- 62 -
4.3.3.2 Ascorbic acid content .....	- 63 -
4.3.3.3 Antioxidant activity .....	- 64 -
4.3.3.4 Relation between antioxidant activity and total phenolic content .....	- 65 -
4.3.4 Colour analysis.....	- 65 -
4.4 Intercalary remarks .....	- 67 -
4.5 References.....	- 68 -
<b>Chapter 5 Conclusions and Future Perspectives .....</b>	<b>- 71 -</b>
5.1 General Conclusions.....	- 73 -
5.2 Suggestions for Future Research .....	- 75 -
<b>A. Annexes .....</b>	<b>- 77 -</b>

## List of figures

---

Figure 2.1. Water activity profile in the OE process (Alves, Koroknai, Bélafi-Bakó, & Coelho, 2004) . -	11 -
Figure 2.2. Temperature profiles due to polarization in OE process (Bui, Nguyen, & Joachim, 2005)- 12	-
Figure 2.3 Experimental setup: (1) membrane contactor; (2) calcium chloride anhydrous solution reservoir; (3) water/sucrose solution reservoir; (4) balance; (5) pump; (6) flow meter; (7) pressure gauge; (8) thermocouple. ....	21 -
Figure 2.4 Relation between the calcium chloride anhydrous solution and the water flux for OE experiments. ....	23 -
Figure 2.5 Overall mass transfer coefficient for the experiments carried out varying the Reynolds number in the fibres, for different CaCl <sub>2</sub> solutions (Shell side: deionized water, Re = 2.17). Orange line: membrane mass transfer coefficient. ....	23 -
Figure 2.6 Water flux as a function of the Reynolds number in the shell side of the module, for three different sucrose solutions (fibres:CaCl <sub>2</sub> (5M), Re = 0.9).....	24 -
Figure 2.7 Overall mass transfer coefficients for the experiments carried out varying the Reynolds number in the shell side of the module, for three different sucrose solutions (fibres:CaCl <sub>2</sub> (5M), Re = 0.9) .....	25 -
Figure 2.8 Relation between experimental data (points) and the correlation obtained by Viegas et al. (Dashed Line) for the mass transfer coefficient on the fibres side of the module. Correlation with the alteration of $\alpha$ parameter from 0.2 to 0.6 (Line).....	26 -
Figure 2.9 Relation between the experimental data (dots) and the correlation obtained by Yang and Cussler (Dashed Line) for the mass transfer coefficient on the shell side of the module. Correlation with the alteration of $\alpha$ parameter from 1.25 to 0.7 (Line).....	26 -
Figure 3.1. Water flux as a function of the time. Green – Medicinal Rosil N° 6 tea; Brown – Black tea; Pink – Forest Fruit tea. ....	38 -
Figure 3.2 Overall mass transfer coefficient as a function of the time. Green – Medicinal Rosil N° 6 tea; Brown – Black tea; Pink – Forest Fruit tea. ....	39 -
Figure 3.3. Driving force as a function of the time. Green – Medicinal Rosil N° 6 tea; Brown – Black tea; Pink – Forest Fruit tea. ....	40 -
Figure 3.4 Variation of the water flux and total solids content (TS) through the concentration process to the Medicinal Rosil N° 6 tea. Blue – Water flux. Green - TS.....	41 -
Figure 3.5. Variation of the water flux and total solids content (TS) through the concentration process to the Black tea. Blue – Water flux. Brown - TS. ....	41 -
Figure 3.6. Variation of the water flux and total solids content (TS) through the concentration process to the Forest Fruit tea. Blue – Water flux. Pink - TS.....	41 -
Figure 3.7 Total phenolic content through the concentration process. Brown – Black tea; Green – Medicinal Rosil N° 6 tea; Pink – Forest Fruit tea.....	42 -

Figure 3.8. Antioxidant activity through concentration process by FRAP method. Brown – Black tea; Pink – Forest Fruit tea; Green – Medicinal Rosil N° 6 tea.....	43 -
Figure 3.9. Antioxidant activity through concentration process by DPPH method. Brown – Black tea; Pink – Forest Fruit tea; Green – Medicinal Rosil N° 6 tea.....	43 -
Figure 3.10 Relation between phenolic content and antioxidant activity (FRAP) to the medicinal Rosil N° 6 tea.....	45 -
Figure 3.11 Relation between phenolic content and antioxidant activity (DPPH) to the medicinal Rosil N° 6 tea.....	45 -
Figure 3.12 Relation between phenolic content and antioxidant activity (FRAP) to the Black tea ...	45 -
Figure 3.13 Relation between phenolic content and antioxidant activity (DPPH) to the Black tea ...	45 -
Figure 3.14 Relation between phenolic content and antioxidant activity (FRAP) to the Forest Fruit tea .	45 -
Figure 3.15 Relation between phenolic content and antioxidant activity (DPPH) to the Forest Fruit tea	45 -
Figure 4.1 Water flux as a function of the time performed with 1.7 x 55 MiniModule. ....	59 -
Figure 4.2 Concentration of Orange Juice as a function of the time using the 2.5 x 8 EXTRA-FLOW Liqui-Cel module.....	60 -
Figure 4.3 Water flux as a function of the time using the 2.5 x 8 EXTRA-FLOW Liqui-Cel module. ....	61 -
Figure 4.4 Driving force as a function of the time using the 2.5 x 8 EXTRA-FLOW Liqui-Cel module. ....	61 -
Figure 4.5 Overall mass transfer coefficient as a function of the time using the 2.5 x 8 EXTRA-FLOW Liqui-Cel module.....	61 -
Figure 4.6 Total phenolic content through the concentration process for orange juice. ....	62 -
Figure 4.7 Antioxidant activity through concentration process by FRAP method for orange juice ...	64 -
Figure 4.8 Antioxidant activity through concentration process by DPPH method for orange juice....	64 -
Figure 4.9 Relation between phenolic content and antioxidant activity (FRAP) for orange juice. ....	65 -
Figure 4.10 Relation between phenolic content and antioxidant activity (DPPH) for orange juice. ...	65 -
Figure A.1 Dimension specifications for the 1.7 x 55 MiniModule membrane contactor. ....	80 -
Figure A.2 Dimension specifications for the 2.5 x 8 EXTRA-FLOW Liqui-Cel membrane contactor.-	81 -
Figure A.3 Temperature profile for the Medicinal Rosil N° 6 tea concentration process. Fibres: CaCl <sub>2</sub> 5M.....	84 -
Figure A.4 Temperature profile for the Black tea concentration process. Fibres: CaCl <sub>2</sub> 5M.....	84 -
Figure A.5 Temperature profile for the Forest Fruit tea concentration process. Fibres: CaCl <sub>2</sub> 5M....	84 -
Figure A.6 Temperature profile for the Orange juice concentration process. Fibres: CaCl <sub>2</sub> 5M.....	84 -
Figure A.7 Calibration curve for FRAP method. ....	85 -
Figure A.8 Calibration curve for DPPH method. ....	85 -
Figure A.9 Calibration curve for the Folin-Ciocalteu method. ....	85 -
Figure A.10 Calibration curve for the 2,6 – dichlorophenolindophenol – Xylene extraction method.-	85 -
Figure A.11 Concentrated orange juice viscosity curve. ....	86 -

## List of tables

---

Table 2.1 Mass transfer correlations used to predict the individual mass transfer coefficients .....	- 16 -
Table 3.1 Main ingredients of teas .....	- 34 -
Table.3.2 Initial and final permeate fluxes during tea concentration process .....	- 38 -
Table 3.3 Average of the overall Mass transfer coefficients ( $10^{-11} \text{ m}^{-1} \text{ s}^{-1} \text{ Pa}^{-1}$ ) for each tea during the OE process .....	- 39 -
Table 3.4 Differences in the colour of teas before and after the concentration process. Subscripts I, F and R represents Initial juice, Final juice and Reconstituted to the initial concentration juice respectively. ....	- 46 -
Table 4.1 Characteristics table of the two membrane contactors used in the concentration process of fresh Orange juice. ....	- 56 -
Table 4.2 Effective mass of phenolics (mg GAE) during the concentration process. ....	- 62 -
Table 4.3 Ascorbic acid content before and after the Orange juice concentration process by OE....	- 63 -
Table 4.4 Differences in the colour of orange juice before and after the concentration process. Subscripts I, F and R represents Initial juice, Final juice and Reconstituted to the initial concentration juice respectively.....	- 65 -
Table 4.5 Whiteness index and browning index for the orange juice before and after (reconstituted for the initial concentration) the concentration process. ....	- 66 -
Table A.1 Specifications for 1.7 x 55 MiniModule. ....	- 79 -
Table A.2 Specifications for 2.5 x 8 EXTRA-FLOW Liqui-Cel.....	- 80 -
Table A.3 Characteristics of Celgard, X50-215 Microporous Hollow Fiber Membrane.....	- 82 -
Table A.4 Calcium chloride characteristics corresponded to 25 °C used in the hydrodynamic calculations .....	- 83 -
Table A.5 Operating conditions for the viscosity measure of the concentrated orange juice. ....	- 86 -



## List of abbreviations

---

### Abbreviations

AACC	American Association Cereal Chemistry
BI	Browning index
CIE	Comission Internationale de l'Eclairage (International Commission on Illumination)
DGM	Dusty Gas Model
DPPH	Diphenylpicrylhydrazyl
F <sup>2+</sup> TPTZ	Ferrous – tripyridyltriazine
F <sup>3+</sup> TPTZ	Ferric – tripyridyltriazine
FO	Forward osmosis
FRAP	Ferric reducing ability power
GAE	Galic acid equivalent
MD	Membrane distillation
OE	Osmosis evaporation
PP	Polypropylene
PTFE	Polytetrafluoroethylene
PVDF	Polyvinylidene fluoride
TE	Trolox equivalent
TEAC	Trolox equivalent antioxidant activity
TS	Total solids
UV/ Vis	Ultraviolet – visible spectroscopy
WI	Whiteness index

### Variables

a	Water activity (dimensionless)
A	Membrane area (m <sup>2</sup> )
C*	Chroma value (dimensionless)
dh	Hydraulic diameter (m)
dp	Membrane pore size (m)
Dw	Water diffusion coefficient in the aqueous solution (m <sup>2</sup> s <sup>-1</sup> )
h°	Hue angle (dimensionless)
Jw	Water flux (m <sup>3</sup> m <sup>-2</sup> s <sup>-1</sup> )
k	Individual mass transfer coefficient (m s <sup>-1</sup> )
kmp	Membrane mass transfer coefficient (m s <sup>-1</sup> Pa <sup>-1</sup> )
Kp	Overall mass transfer coefficient (m s <sup>-1</sup> Pa <sup>-1</sup> )
L*	Lightness value (dimensionless)

M	Molality (mol L <sup>-1</sup> )
M <sub>w</sub>	Water molar mass (Kg mol <sup>-1</sup> )
P	Total pressure (Pa)
P <sup>*w</sup>	Pure water vapour pressure (Pa)
R	Gas constant (K K <sup>-1</sup> mol <sup>-1</sup> )
Re	Reynolds number (dimensionless)
Sc	Schmidt number (dimensionless)
Sh	Sherwood number (dimensionless)
T	Temperature (K)
v	Cross flow velocity (m s <sup>-1</sup> )
Δa <sup>*</sup>	Difference on red / green axis (dimensionless)
Δb <sup>*</sup>	Difference on yellow / blue axis (dimensionless)
ΔE <sup>*</sup>	Total colour difference value (dimensionless)
ΔL <sup>*</sup>	Difference in lightness / darkness value (dimensionless)

### Greek symbols

α	Constant (dimensionless)
β	Constant (dimensionless)
δ	Membrane thickness (m)
ε	Membrane porosity (dimensionless)
φ	Fibre packing fraction (dimensionless)
η	Viscosity (Pa s)
μ	Absolute viscosity (N s m <sup>-2</sup> )
ρ	Density (Kg m <sup>-3</sup> )
τ	Membrane tortuosity (dimensionless)
γ̇	Shear rate (s <sup>-1</sup> )

### Subscripts

l <sub>m</sub>	Logarithmic mean
m	Membrane
s	Shell
t	Tube / fibres
w	water

# Chapter 1

---

## Thesis Introduction



## 1.1 Background and Motivation

Natural beverages consumption is increasing due to their nutritional value and high levels of antioxidants, favouring health and well-being of the consumer. Teas with a global consumption of about 20% of the total consumption of beverages, and fresh juices with an annual growth of about 2% are examples of beverages which are being increasingly consumed due to their pleasant flavour and nutritional value (Neves, et al., 2010).

Tea consumption dates from the 27th century B.C. and today remains in the diet of millions of people, being one of the oldest beverages produced by biotechnological methods (Morais, Cavalcanti, Costa, & Aguiar, 2009). The interest in tea comes mainly from its aromas as well as the beneficial effect that the beverage can play in the health of consumers.

Depending on the processing used there are traditionally classified four types of tea distinguished by the degree of oxidation (Ruan, Wu, & Härdter, 1999).

- White tea: Tea developed from young leaves not subjected to any oxidative process.
- Green tea: Developed from tea leaves that already have some oxidative process, but which is stopped by the application of heat in the vapour form.
- Black tea: Tea made from leaves with a high degree of oxidation.
- Oolong tea: Tea with a degree of oxidation between green teas and black teas.

Nearly half of the dry matter of teas is insoluble in water and some of its constituents are polyphenols, amino acids, caffeine, sugars and fatty acids. The most significant groups in the context of this work are polyphenols and vitamins. The polyphenols in tea represent about 25% of dry matter and belong mostly to the group of flavonoids or catechins depending on the type of tea. Regarding to vitamins present in tea the importance lies on riboflavin (vitamin B2) which remains constant during the processing of tea and ascorbic acid (vitamin C) which is completely oxidized during the oxidative process of tea (Lima, Mazzafera, Moraes, & Silva, 2009).

In the field of fruit juices, the orange juice is, according to Markestrat data consultancy, the most consumed one, representing 32% of the consumers' preferences (Neves, et al., 2010). Therefore, orange juice was selected in this study, not only for its economic importance, but also because of the importance of oranges in Portugal.

Orange is one of the most consumed fruits in the world, taking up an area of 20361 hectares in Portugal. Algarve region is one of the largest producing areas, representing 69% of the total orange's European production (Publicações: O Mercado da Laranja em Portugal, 2014).

In its nutritional composition the high level of vitamin C, folic acid and minerals stands out. The orange's antioxidant properties are due fundamentally to beta-carotene, also responsible for the orange colour.

The way that nowadays the drinks reach the market place depends on the type of beverages.

Teas are generally commercialized in the form of leaves or as liquid product. However, several recognized brands have already tried to innovate the product image through new forms of consumption, and in China are now produced each year, about fifteen thousand tons of tea concentrates (Xu, Chen, Yuan, Tang, & Yin, 2012).

The fruit juices like orange juice can currently reach the market in two general forms (Gil-Izquierdo, Gil, & Ferreres, 2002):

- Fresh product, collected directly from the raw material and subjected to pasteurization;
- Concentrated product.

From the commercial point of view, the beverages' concentration has a great interest due to the decrease of transportation, storage and packaging costs, as well as the product's shelf life increase originated by its higher resistance to microbial activity (Álvarez, et al., 2000; Cassano, et al., 2003; Alves & Coelho, 2006; Galaverna, et al., 2008). In addition, the beverages' concentration allows assuring the availability of seasonal products during the whole year, thus showing economic advantages and increasing the importance of agricultural products (Álvarez, et al., 2000).

During the beverages' concentration process, water must be selectively removed, thus making it possible for the consumer, through water addition, obtain a beverage similar to the original, in terms of appearance, flavour and nutritional quality (Alves & Coelho, 2006).

The industrial processes used currently to concentrate beverages involve typically multi-stage vacuum evaporation (Petrotos & Lazarides, 2001). This commercial concentration process is based on a heat treatment, thereby implying alterations on the quality of the concentrated beverages, both in terms of organoleptic properties, such as colour and aroma compounds, and phenolic compounds content (Barbe, Bartley, Jacobs, & Johnson, 1998; Nii, Jebson, & Cussler, 2002).

Moreover, these industrial processes involve by high energetic costs that emphasize their disadvantages (Cassano, et al., 2003).

In order to overcome the negative aspects of the concentration process performed under high temperature, studies have emerged on alternative techniques. Freeze-concentration is a process used industrially in order to concentrate fruit juice. In this process, the water is removed in the form of crystals, allowing the flavour preservation and the maintenance of the chemical and biochemical product properties (Ramos, Delgado, Bautista, Morales, & Duque, 2005). However, this technique can only be applied to clarified liquid foods, revealing low productivity, not only because of the low degree of final concentration accomplished (40 to 55%), but also because of the significant product losses occurred (Dova, Petrotos, & Lazarides, 2007). Consequently, the disadvantages of this process are evident, especially in what regards to the high costs associated to this technique.

Alternatively, there are membrane processes, such as Forward Osmosis (FO), Membrane Distillation (MD) and Osmotic Evaporation (OE), besides the membrane filtration process. Membrane processes operate under ambient temperature and pressure, being in this way able to overcome many

limitations of conventional evaporation process and allowing the beverages' concentration at a higher level, not occurring the thermal and chemical damages referred (Alves & Coelho, 2002; Cassano, et al., 2003). The operating pressure and temperature assure the advantage of a minor energetic cost associated, when compared to pressure driven membrane process.

Several authors have pointed out the use of integrated membrane processes as a viable alternative to currently used thermal concentration process (Álvarez, et al., 2000; Petrotos & Lazarides, 2001; Cassano, et al., 2003; Galaverna, et al., 2008).

Forward osmosis uses an osmotic solution in order to create an osmotic pressure gradient through a membrane that is permeable to water and impermeable to the solute, enabling the water removal during the concentration process. This technique allows achieving high final concentration without fouling. This technique main disadvantages are related to the membranes, namely the possibility of some salt diffusion through the membrane, as well as the membrane's lifetime and, inevitably, the maintenance cost associated to the membrane replacement and reconcentration of the osmotic solution (Petrotos & Lazarides, 2001; Zhao, Zou, Tang, & Mulcahy, 2012).

Reverse osmosis can also be used, but in this case the water removal is due to the pressure gradient applied, that compared to the other membrane technologies, is higher (24 - 100 bar) (Martins, 2006). The final concentration content is limited to 20% of soluble solids (Álvarez, et al., 2000; Cassano, et al., 2003).

The membrane distillation is a technology in which two aqueous solutions are separated by a hydrophobic and microporous membrane. This process' driving force is the water vapour pressure difference between the two solutions on the process (Cassano, et al., 2003). On an experimental situation, the two solutions are under different temperatures and this thermal gradient induces the water flux from the solution of higher temperature to the solution of lower temperature. This process, when applied to beverages' concentration is limited in what concerns to flux and aromas' retention (Alves & Coelho, 2006).

In the osmotic evaporation process, a hydrophobic, microporous membrane separates two solutions, one of them being a salt solution. Osmotic evaporation has advantages when compared to reverse osmosis, as it allows achieving juice concentrations similar to the industrial evaporation process because it does not show osmotic pressure limitations (Gostoli, 1999). Furthermore, osmotic evaporation overcomes membrane distillation because it allows isothermal operations, which is crucial for the concentration of a variety of beverages (Alves & Coelho, 2006). This process also preserve the beverage's aroma and nutritional value (Cassano, et al., 2003; Galaverna, et al., 2008; Cassano, Conidi, & Drioli, 2010; Onsekizoglu, Bahceci, & Acar, 2010; Torun, et al., 2014).

## 1.2 Objectives and Thesis outline

The aim of the present work is to study the potential of the osmotic evaporation process for the concentration of beverages (teas and orange juice), assessing its effect on the overall quality of the concentrated products obtained. The work has three specific objectives:

- Evaluation of the optimal hydrodynamic conditions for the experimental setup used, in which was used an hollow fibre membrane contactor;
- Study of the concentration process of four beverages (orange juice and teas) by osmotic evaporation, operating with the optimized operating conditions;
- Evaluation of bioactive compounds content and antioxidant activity throughout the concentration process.

This thesis describes the study of the osmotic evaporation process applied to the concentration of orange juice and teas. It is organized in five chapters. Each one includes a short review of the state of the art, describes the materials and methods used in that chapter and presents the results discussion and the main conclusions obtained in that part of the work. A description of the chapters is presented below in more detail.

Chapter 1 consists on a general introduction of the research area in which this thesis is included, presenting the motivation and specific objectives of the work developed.

Chapter 2 is focused on to the optimization of the operating conditions of osmotic evaporation process. It includes the evaluation of the mass transfer coefficients, for the tube side and shell side, as well as the selection of the most suitable mass transfer correlations to describe mass transfer from those referred in the literature.

Chapter 3 presents the study of the osmotic evaporation process applied to the concentration of teas. This chapter analyses the process of concentration itself as well as the bioactive compounds content, antioxidant activity and colour during the concentration process.

Chapter 4 describes the osmotic evaporation process applied to the concentration of orange juice. As in chapter three, it is also focused on the evaluation of antioxidant activity, bioactive components and colour alterations of the juice during the concentration process.

Chapter 5 presents the final conclusions of this study as well as suggestions for future developments.

### 1.3 References

AACC International. Approved Methods of Analysis, 11<sup>th</sup> Ed. Method 86-10.01. Ascorbic Acid - Indophenol-Xylene Extraction Method. Approved November 3, 1999. AACC International, St Paul, MN, USA. <http://dx.doi.org/10.1094/AACCIntMethod-86-10.01>

Álvarez, S., Riera, F. A., Álvarez, R., Coca, J., Cuperus, F. P., Bouwer, S. T., Boswinkel, G., Gemert, R.W., Veldsink, J.W., Giorno, L., Donato, L., Todisco, S., Drioli, E., Olsson, J., Trägårdh, G., Gaeta, S.N., Panyor, L. (2000). A new integrated membrane process for producing clarified apple juice and apple juice aroma concentrate. *Journal of Food Engineering*, *46*, 109-125.

Alves, V. D., & Coelho, I. M. (2002). Mass transfer in osmotic evaporation: effect of process parameters. *Journal of Membrane Science*, *208*, 171-179.

Alves, V. D., & Coelho, I. M. (2006). Orange juice concentration by osmotic evaporation and membrane distillation: A comparative study. *Journal of Food Engineering*, *74*, 125-133.

Barbe, A. M., Bartley, J. P., Jacobs, A. L., & Johnson, R. A. (1998). Retention of volatile organic flavour/fragrance components in the concentration of liquid foods by osmotic distillation. *Journal of Membrane Science*, *145*, 67-75.

Cassano, A., Drioli, E., Galaverna, G., Marchelli, R., Silvestro, G. D., & Cagnasso, P. (2003). Clarification and concentration of citrus and carrot juices by integrated membrane processes. *Journal of Food Engineering*, *57*, 153-163.

Cassano, A., Conidi, C., & Drioli, E. (2010). Physico-chemical parameters of cactus pear (*Opuntia ficus-indica*) juice clarified by microfiltration and ultrafiltration processes. *Desalination*, *250*, 1101-1104.

Dova, M. I., Petrotos, K. B., & Lazarides, H. N. (2007). On the direct osmotic concentration of liquid foods. part I: Impact of process parameters on process performance. *Journal of Food Engineering*, *78*, 422-430.

Galaverna, G., Silvestro, G. D., Cassano, A., Sforza, S., Dossena, A., Drioli, E., & Marchelli, R. (2008). A new integrated membrane process for the production of concentrated blood orange juice: Effect on bioactive compounds and antioxidant activity. *Food Chemistry*, *106*, 1021-1030.

Gardner, P. T., White, T. A., McPhail, D. B., & Duthie, G. G. (2000). The relative contributions of vitamin C, carotenoids and phenolics to the antioxidant potential of fruit juices. *Food Chemistry*, *68*, 471-474.

Gil-Izquierdo, A., Gil, M. I., & Ferreres, F. (2002). Effect of Processing Techniques at Industrial Scale on Orange Juice Antioxidant and Beneficial Health Compounds. *Journal of Agricultural and Food Chemistry*, *50*, 5107-5114.

Gostoli, C. (1999). Thermal effects in osmotic distillation. *Journal of Membrane Science*, *163*, 75-91.

Lima, J. D., Mazzafera, P., Moraes, W. S., & Silva, R. B. (2009). Tea: aspects related to the quality and prospects. *Ciência Rural*, *39*, 1270-1278.

Martins, F. L. (2006). Desenvolvimento experimental, modelagem e simulação do processo de evaporação osmótica para concentração de soluções de sacarose contendo aroma de frutas tropicais. Tese de Doutorado em Engenharia Química, Universidade Federal do Rio de Janeiro, Brasil.

Morais, S. M., Cavalcanti, E. S. B., Costa, S. M. O., & Aguiar, L. A. (2009). Ação antioxidante de chás e condimentos de grande consumo no Brasil. *Brazilian Journal of Pharmacognosy*, 19, 315-320.

Neves, M. F., Trombin, V. G., Milan, P., Lopes, F. F., Cressoni, F., & Kalaki, R. (2010). *O retrato da citricultura brasileira*. Brasil: Markestrat.

Nii, S., Jebson, R. S., & Cussler, E. L. (2002). Membrane evaporators. *Journal of Membrane Science*, 201, 149-159.

Onsekizoglu, P., Bahceci, K. S., & Acar, M. J. (2010). Clarification and the concentration of apple juice using membrane processes: A comparative quality assessment. *Journal of Membrane Science*, 352, 160-165.

Petrotos, K. B., & Lazarides, H. N. (2001). Osmotic concentration of liquid foods. *Journal of Food Engineering*, 49, 201-206.

*Publicações: O Mercado da Laranja em Portugal*. (June 30, 2014). Obtained of Observatório dos Mercados Agrícolas e das Importações Agro-Alimentares: [http://www.observatorioagricola.pt/item.asp?id\\_item=129](http://www.observatorioagricola.pt/item.asp?id_item=129)

Ramos, F. A., Delgado, J. L., Bautista, E., Morales, A. L., & Duque, C. (2005). Changes in volatiles with the application of progressive freeze-concentration to Andes berry (*Rubus glaucus* Benth). *Journal of Food Engineering*, 69, 291-297.

Ruan, J., Wu, X., & Härdter, R. (1999). Effects of potassium and magnesium nutrition on the quality components of different types of tea. *Journal of the Science of Food and Agriculture*, 79, 47-52.

Torun, M., Rácz, G., Fogarassy, E., Vatai, G., Dinçer, C., Topuz, A., & Özdemir, F. (2014). Concentration of sage (*Salvia fruticosa* Miller) extract by using integrated membrane process. *Separation and Purification Technology*, 132, 244-251.

Xu, Y., Chen, S., Yuan, H., Tang, P., & Yin, J. (2012). Analysis of cream formation in green tea concentrates with different solid concentrations. *Journal of Food Science and Technology*, 49, 362-367.

Zhao, S., Zou, L., Tang, C. Y., & Mulcahy, D. (2012). Recent developments in forward osmosis: Opportunities and challenges. *Journal of Membrane Science*, 396, 1-21.

## Chapter 2

---

# Optimization of the operating conditions in OE





The water flux is proportional to the water vapour pressure difference between both phases:

$$J_w = K_p \Delta p_{wb} \Leftrightarrow J_w = K_p (P_1 - P_2)$$

Equation 2.1

Where  $K_p$  is the overall mass transfer coefficient ( $m s^{-1} Pa^{-1}$ ) and  $P_1$  and  $P_2$  correspond respectively to the water's vapour pressure of the solutions in the sell side and in the fibres (Pa).

Concerning the water's vapour pressure, it can be related to the water's activity according to the equation 2.2.

$$P_i = a_i P_i^*$$

Equation 2.2

Where  $a_i$  is the water activity in the two phases and  $P_i^*$  is the pure water vapour pressure (Pa). This way, the water saturation vapour pressure at the bulk temperature is given by the respective Antoine equation, as represented in equation 2.3 (Poling, Prausnitz, & O'Connell, 2001).

$$P^* = \exp \left[ 23,2 - \left( \frac{3816,2}{T(K) - 46,1} \right) \right]$$

Equation 2.3

Due to the low temperatures, the water fluxes obtained are low, representing a disadvantage to the technology industrialisation. To overcome this situation and increase mass transfer rate the use of membrane contactors with high specific areas, easy scale-up and low manufacturing costs, will make this technique very promising for the concentration process at industrial scale (Alves, Koroknai, Bélafi-Bakó, & Coelho, 2004). The hollow fibre modules use microporous fibres that are woven into a fabric that allows more uniform fibre spacing, which in turn leads to higher mass transfer coefficients than those obtained with individual fibres (Gabelman & Hwang, 1999). In this master thesis it was used a hollow fibre module with parallel flow in the shell side.

The temperature polarization is a phenomenon observed during the process of mass transfer in osmotic evaporation technology. This phenomenon occurs due to the evaporation of water from the feed side which promotes a temperature reduction along the boundary layer and a consequent increase in the temperature of the brine side, because of the condensation of water in that side of the membrane. The temperature profiles during the process of mass transfer are shown in figure 2.2.

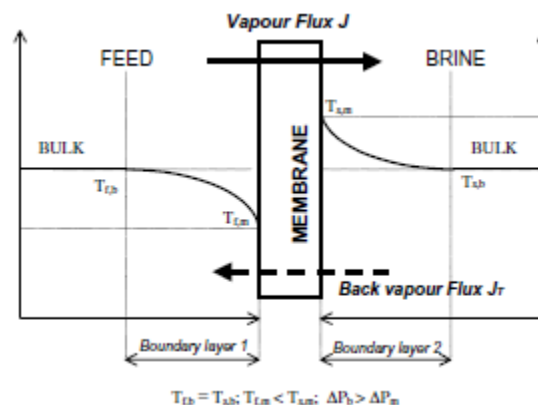

Figure 2.2. Temperature profiles due to polarization in OE process (Bui, Nguyen, & Joachim, 2005)

Thinner membranes with higher heat conductivity, allow a more efficient process because the thermal equilibrium is reached more quickly, minimizing the effect of temperature polarization (Kunz, Benhabiles, & Ben-Ain, 1996). Temperature monitoring during the process of mass transfer is important in order to minimize the difference of chemical potential that can happen due to the variations related with the temperature.

Nevertheless, the temperature polarization phenomenon represents a small contribution compared to the concentration polarization phenomenon (Bui, Nguyen, & Joachim, 2005).

During the process of osmotic evaporation, water evaporates from the solution to be concentrated and the vapour is transported to the opposite side where condensation occurs, leading to dilution of the osmotic solution. The processes of evaporation and condensation on the membrane interfaces, induces the increasing of the solute concentration in the feed side and the dilution of the solute concentration on the brine side. This phenomenon is known as concentration polarization, and the concentration gradient formed is contrary to the temperature gradient observed (figure 2.1) (Bui, Nguyen, & Joachim, 2005).

As a result, due to the concentration polarization phenomena, the water activity at the membrane interface is different from the bulk water activity resulting on the establishment of two diffusional boundary layers. Consequently, the reduction of the effective driving force takes place due to the existence of three water flux resistances (Alves & Coelho, 2002).

- Boundary layers resistance on both sides of the membrane;
- Membrane resistance.

In this situation, the water flux may be associated with the respective individual mass transfer coefficients by equation 2.4.

$$J_w = k_s(a_s - a_{ms}) = k_t(a_{mt} - a_t)$$

Equation 2.4

Where  $k_s$  and  $k_t$  are the individual mass transfer coefficients in the boundary layers ( $m\ s^{-1}$ ).

The effect of concentration polarization phenomenon is closely related to operational conditions and it is, therefore, easy to minimize by improving the hydrodynamic conditions, namely increasing the Reynolds number ( $Re$ ) on both sides of the membrane (Martins, 2006).

The rate of water transport between the two phases is crucial for the design and cost of systems of osmotic evaporation (Viegas, et al., 1998). Thereby the overall mass transfer coefficient is extremely important, since it limits the rate at which the components are transferred. The overall mass transfer coefficient can be defined as:

$$K_p = \frac{1}{\left(\frac{P_{ws}^*}{k_s}\right) + \left(\frac{1}{k_{mp}}\right) + \left(\frac{P_{wt}^*}{k_t}\right)}$$

Equation 2.5

Where  $K_p$  is the overall mass transfer coefficient ( $m\ s^{-1}\ Pa^{-1}$ );  $P_{ws}^*$  e  $P_{wt}^*$  are the pure water vapour pressures at both sides of the membrane ( $Pa$ );  $k_{mp}$  is the membrane mass transfer ( $m\ s^{-1}\ Pa^{-1}$ ).

The mass transfer coefficient of the membrane ( $k_{mp}$ ) is a value that varies with the partial pressure of air in the pores of the membrane and the composition of the aqueous solutions, which in most cases are not significant factors, causing the  $k_{mp}$  to be assumed as constant (Alves & Coelho, 2002). The membrane mass transfer coefficient ( $k_{mp}$ ) is directly proportional to pore size and porosity of the membrane, and inversely proportional to thickness and tortuosity of the same.  $k_{mp}$  may be described by the Dusty Gas Model (DGM) (Alves, Koroknai, Bélafi-Bakó, & Coelho, 2004):

$$k_{mp} = \frac{1,8 \times 10^{-5}}{RT\delta} \left[ \frac{3\tau}{\varepsilon d_p \left( \frac{8RT}{\pi M_w} \right)^{1/2}} + \frac{\tau p_{air}}{\varepsilon P D_{w-air}} \right]^{-1}$$

Equation 2.6

Where  $d_p$  is the pore size (m);  $\varepsilon$  is the porosity;  $p_{air}$  is the air partial pressure (Pa);  $\tau$  is the tortuosity;  $\delta$  is the membrane thickness (m);  $D_{w-air}$  the water vapour diffusion coefficient in air;  $M_w$  the water molar weight ( $\text{kg mol}^{-1}$ );  $R$  is the gas constant ( $\text{JK}^{-1}\text{mol}^{-1}$ );  $T$  the temperature (K);  $P$  the total pressure (Pa).

The overall resistance to mass transfer ( $1/K_p$ ) is the sum of three resistances to the water flux: the resistance of the boundary layer in the diluted solution side, the resistance of the membrane and the resistance of the boundary layer in the osmotic solution side.

Considering a situation where the concentration polarization is negligible, which means that resistance occurs only in the membrane, the overall mass transfer coefficient is equivalent to the membrane mass transfer coefficient. If the boundary layers cannot be neglected, the dependence of the individual mass transfer coefficient of both sides of the membrane can be correlated according to the general mass transfer correlation (Alves & Coelho, 2002):

$$Sh = \alpha Re^\beta Sc^\gamma$$

Equation 2.7

Where  $\alpha$ ,  $\beta$  e  $\gamma$  are constants. The dimensionless numbers are defined as follows (Bui, Nguyen, & Joachim, 2005):

$$Sh_i = \frac{k_i \times d_{hi}}{D_{iw}} \quad Re_i = \frac{v_i \times d_{hi} \times \rho_i}{\mu_i} \quad Sc_i = \frac{\mu_i}{D_{iw} \times \rho_i}$$

Where the subscript (i) can represent either the fibre values or the shell values;  $d_h$  is the hydraulic diameter (m);  $\rho$  is the density ( $\text{kg m}^{-3}$ );  $v$  is the cross-flow velocity ( $\text{m s}^{-1}$ );  $\mu$  is the viscosity of the liquids (Pa.s).

The evaluation of the mass transfer coefficients is extremely important for the design of mass transfer equipment.

For hollow fibres, the evaluation of correlations is more complicated since these membranes are flexible and irregularly distributed in the shell, the Reynolds numbers for the well-packed membrane modules are very low and the mass transfer takes place in the laminar flow regime. As a result, the flow outside the fibres in the membrane modules has a much more complicated profile and for that reason is mathematically more difficult to predict (Gawronski & Wrzesinska, 2000).

The mass transfer correlations in the fibres are generally similar and applied to a large number of cases. However, the same cannot be considered for the shell side. In this context, there are several correlations determined by different authors, but none of them is applicable to a high number of experimental conditions (Gawronski & Wrzesinska, 2000). It is still possible to conclude:

- The shell side Sherwood number strongly depends on the fibre packing density;
- The fibre Sherwood number is independent of the module packing density;
- Mass transfer is influenced by the inlet ports design and module geometry.

Table 2.1 lists some of the correlations used in hollow fibre membrane contactors.

Table 2.1 Mass transfer correlations used to predict the individual mass transfer coefficients

Equation	Author	Comment	Reference
<i>Tube side flow</i>			
$Sh=2.66Re^{0.25} Sc^{0.33} (d/L)^{0.33}$	Alves et al.	Correlation valid for Reynolds between 0.5 and 45.	(Alves & Coelho, 2007)
$Sh=1.62Re^{0.33} Sc^{0.33} (d/L)^{0.33}$	Lévêque	Equation that predicts with reasonable accuracy the mass transfer coefficients for high Graetz.	(Gawronski & Wrzesinska, 2000)
$Sh=0.2Re^{1.01} Sc^{0.33} (d/L)^{0.33}$	Viegas et al.	Obtained correlation for $Re < 24$ e $Gz < 65$ .	(Viegas, et al., 1998)
$Sh=1.5 ((d/L)ReSc)^{0.33}$	Dahuron and Cussler	Equation obtained with electrolytes and protein extraction trials.	(Gawronski & Wrzesinska, 2000)
$Sh=1.64((d/L)ReSc)^{0.33}$	Yang and Cussler	Obtained equation for gas absorption.	(Gawronski & Wrzesinska, 2000)
<i>Shell side flow parallel to the fibres</i>			
$Sh=15.4Re^{0.92} Sc^{0.33} (dh/L)$	Alves et al.	Correlation valid for Reynolds between 0.5 and 45.	(Alves & Coelho, 2007)
$Sh=8.71Re^{0.74} Sc^{0.33} (dh/L)$	Viegas et al.	Obtained correlation with solvent extraction tests, applied at low Reynolds ( $0.16 < Re < 7.30$ )	(Viegas, et al., 1998)
$Sh=8.8Re Sc^{0.33} (dh/L)$	Dahuron and Cussler	Equation obtained for extraction solvents with packing factor equal to 0.15.	(Gabelman & Hwang, 1999)
$Sh=5.85Re^{0.6} Sc^{0.33} (dh/L)$	Prasad and Sirkar	Correlation obtained for liquid-liquid extraction trials applied to different types of solutes and solvents and $Re < 500$ .	(Gabelman & Hwang, 1999)
$Sh=0.022Re^{0.6} Sc^{0.33}$	Knudsen and Katz	Correlation does not apply generally in membrane contactors.	(Gabelman & Hwang, 1999)
$Sh=1.25(Re dh/L)^{0.93} Sc^{0.33}$	Yang and Cussler	Equation obtained for high Reynolds range ( $0.5 < Re < 500$ ) in tests of stripping gas.	(Gabelman & Hwang, 1999)

$Sh=(0.53-0.58\phi)Re^{0.53}Sc^{0.33}$	Costello et al.	Correlation obtained for the gas removal applied to Reynolds higher than 20 ( $20 < Re < 300$ ).	(Gabelman & Hwang, 1999)
<i>Hollow fibre fabric</i>			
$Sh=0.82Re^{0.49} Sc^{0.33}$	Wickramasinghe et al.	Average of correlations developed using four different configurations, with $0.001 < Re < 10$ .	(Gabelman & Hwang, 1999)
$Sh=0.18Re^{0.86} Sc^{0.33}$	Wang and Cussler	Developed using a rectangular module.	(Gabelman & Hwang, 1999)
$Sh=0.46Re^{0.46} Sc^{0.33}$	Wang and Cussler	Developed using a baffled cylindrical module, similar to other correlations obtained with modules having uniform fibre spacing.	(Gabelman & Hwang, 1999)
$Sh=0.57Re^{0.31} Sc^{0.33}$	Bhaumik et al.	Developed using a cylindrical module with liquid flow perpendicular to the fibres.	(Gabelman & Hwang, 1999)

During the process of osmotic evaporation, there are several parameters that influence the process. In the following pages, the most relevant factors will be discussed in order to understand how they can affect the process.

The membrane to be used in an osmotic evaporation process should be microporous, hydrophobic and composed of a polymeric material.

The water transport through the membrane occurs in the form of vapour through the pores. Consequently, as the pore diameter increases, the molecular diffusion also increases (Alves & Coelho, 2004).

The membrane thickness is also important because it determines the water diffusion path, and must be low, thus minimizing the resistance of the membrane.

Therefore the ideal membranes for osmotic evaporation processes are polymeric membranes formed by materials such as polytetrafluoroethylene (PTFE), polypropylene (PP) or polyvinylidene fluoride (PVDF) with pore diameters between 0.01 to 1.0  $\mu\text{m}$ , thickness from 10 to 300  $\mu\text{m}$  and porosity between 40 and 80% (Kunz, Benhabiles, & Ben-Aïn, 1996; Courel, Tronel-Peyroz, Rios, Dornier, & Reynes, 2001).

Another important feature with respect to the osmotic evaporation membranes is the relation between hydrophobicity and wettability. With the purpose of the occurrence of the osmotic evaporation, according to the theoretical principles that support it, is necessary to ensure the integrity of the gas phase supported by the material constituting the membrane. If membrane wetting occurs, caused by the pressure difference resulting from the movement of fluids, an additional liquid flow occurs, leading to mixing of solutions and consequently the passage of all non-volatile constituents of the solution, leading to the incorrect operability of the process (Courel, Tronel-Peyroz, Rios, Dornier, & Reynes, 2001).

The hydrodynamic conditions play a major role in the phenomenon of mass transfer. The optimum hydrodynamic conditions must be determined for each situation, but in general are associated with higher Reynolds numbers obtained with higher flow velocities.

The increased flow velocity on the osmotic solution side reduces the thickness of the boundary layer providing a superior driving force and therefore superior flux to a point where it stabilizes (Alves & Coelho, 2007).

Likewise increasing the velocity on the side of the solution to be concentrated reduces the effect of concentration polarization, also increasing the flux. However, the increase of the flow velocity must consider the limits of the pressure difference between the two sides of the membrane so that there does not occur penetration of liquid water into the pores (Martins, 2006).

The temperature is an important factor in the osmotic evaporation process since it affects the vapour-liquid equilibrium, even though it has a minimal effect on the mass transfer coefficient due to the use of certain osmotic agents that allows, despite of temperature fluctuations, the maintenance of the bulk water activity (Alves & Coelho, 2002).

The water flux increases with the temperature because: (i) with higher temperatures the diffusivity of water vapour in the pores of the membrane is facilitated leading to an increase in membrane mass transfer coefficient, (ii) the driving force increased due to the exponential relation between water vapour pressure and temperature.

The osmotic solution is typically a saline solution. The salt used should be able to reduce the difference in chemical potential between both sides of the membrane, providing the evaporation of water. It should also provide a range of high solubility for different temperatures and be stable in all analysed temperatures. It should not be volatile or react with volatile compounds, and finally must not present incompatible characteristics with the membrane or other materials that compromise the system, ie, should not be corrosive, toxic or destructive. Since the evaporation process has the ultimate goal of being implemented on industrial scale, the economic viability of the selected salt should be taken into account (Michaels, Hill & Jonson, 1998).

Studies with different osmotic agents determined that if the osmotic solutions used have the same water activity and the processes are carried out according to the same hydrodynamic conditions, similar water fluxes are obtained independently of the osmotic agent used. In any case, the choice of an osmotic agent must take into account parameters such as the water activity, viscosity and density of the osmotic solution (Alves & Coelho, 2002).

The osmotic solution is diluted during the mass transfer process. The lower concentration of solutes in this solution corresponds to a higher water activity, smaller density and viscosity of the solution, being the last ones responsible for the improvement of the hydrodynamic conditions. However, the increase of water activity has a greater importance than the decrease in properties of density and viscosity. Therefore, it occurs the reduction of the driving force and consequently a decrease in the permeate flux (Alves & Coelho, 2002).

Regarding the solution to be concentrated, the solids concentration increases during the concentration process because of the reduction of the water volume. The increased concentration of solutes promotes the increase in viscosity. Therefore it is expected the decrease of the water flux and diffusion coefficient. Despite the increasing concentration being equivalent to a reduction of water activity, this decrease is not significant as in osmotic solution, and therefore no significant changes are recorded in the permeate flux until higher concentrations of 40 % are obtained (Vaillant, et al., 2001).

To minimize the viscous effects caused by the increase of the viscosity of the beverages during the concentration process, the solution to be concentrated should circulate in the shell side of the module while the osmotic solution circulates in the lumen of the fibres.

The first papers on membranes were published in the 60's, especially after the discovery of asymmetric membranes technology by Loeb and Sourirajan. The interest in such studies increased with the research on blood oxygenation in the 70's and 80's, and by this time were developed new membranes with potential applications in various areas.

In 1988 Lefebvre announces the osmotic evaporation as a recent technology with eventual success in concentration of liquids such as milk, juice, coffee, tea and other non-food aqueous solutions (Lefebvre, 1988).

By the 90's the first pilot plants to study the osmotic evaporation process begins to emerge.

Sheng, Johnson, & Lefebvre, (1991) studied the effect of operating conditions (flow rate, temperature and concentration) in the osmotic evaporation flux during concentration tests of orange, apple and grape juices, using a PTFE membrane with pore size of 0.2  $\mu\text{m}$  and thickness of 100  $\mu\text{m}$ . These authors found that the flux of water decreases with the increase of concentration of the juice and it is strongly dependent on the osmotic pressure difference. It also concluded that there is a relation between pore size and the obtained water flux in osmotic evaporation process.

Godino, Pena, Zarate, & Mengual, (1995) showed the influence of temperature on osmotic pressure and found that the largest fluxes obtained during osmotic evaporation are acquired with higher temperatures.

Courel, Dornier, Herry, Rios, & Reynes, (2000) determined hydrodynamic factors that can improve the process of osmotic evaporation, namely the increase in temperature. In the same year Bailey, Barbe, Hogan, Johnson, & Sheng, (2000) found that the water flux increases if a previous ultrafiltration step is carried out, because of the reduction in the viscosity of concentrated juice - membrane boundary layer, where the solute concentration is higher.

Alves & Coelho, (2002) analysed the importance of temperature, hydrodynamic conditions, nature and concentration of the osmotic agent applied to osmotic evaporation process. In this article, the authors describe the mass transfer model as a three resistances model.

Alves & Coelho, (2004) evaluated the influence of the pore diameter on the flux of water, describing it according to the following models: (i) dusty-gas; (ii) Knudsen; (iii) molecular diffusion. In addition to this publication Alves, Koroknai, Bélafi-Bakó, & Coelho, (2004) tested the osmotic evaporation process operating on different modules. They concluded that it is possible to operate the process so that only the membrane offers the resistance to mass transfer.

Chapter 2 is intended to study the hydrodynamic conditions of the osmotic evaporation process carried out in a hollow fibre membrane contactor, in order to proceed afterwards to the concentration experiments. The study conducted in this chapter determines the most favourable hydrodynamic operating conditions, which will increase the efficiency and yield of the concentration process.

## 2.2 Experimental

### 2.2.1 Osmotic Evaporation unit and procedures

The experimental setup for osmotic evaporation process is presented in figure 2.3. It consists on a hollow fibre membrane contactor (1.7 x 55 MiniModule) with an effective surface area of 0.54 m<sup>2</sup>. This membrane contactor contains 7400 polypropylene fibres (Celgard X50-215 Microporous Hollow Fibre Membrane) with a nominal pore size of 0.04 µm, 40% porosity, 18 cm long, an internal diameter of 220 µm and a thickness of 40 µm. The description of the membrane contactor and the fibres used in this work are present in annex I.

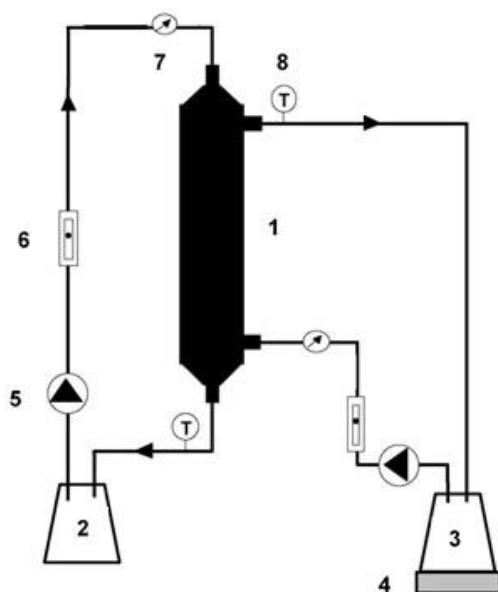

Figure 2.3 Experimental setup: (1) membrane contactor; (2) calcium chloride anhydrous solution reservoir; (3) water/sucrose solution reservoir; (4) balance; (5) pump; (6) flow meter; (7) pressure gauge; (8) thermocouple.

The solutions were prepared with anhydrous calcium chloride (Panreac, Spain) (concentrations 2.5 - 6.7 M), deionized water and sucrose (concentrations of 10% (w/w); 20% (w/w) and 45% (w/w))

The solutions were pumped through the shell side of the module (water or sucrose solution) and lumen of the fibres (calcium chloride anhydrous solution) in a counter-current mode. The calcium chloride anhydrous solution was chosen as osmotic solution because it is non-toxicity, its availability at low cost.

The initial volume of the osmotic solution was 4000 ml in each experimental run, and the calcium chloride anhydrous solution was never substituted during the experimental time. Inlet and outlet pressures of both tube and shell sides, as well as temperature were measured during the concentration processes. The concentration process was performed under room temperature ( $23\text{ °C} \pm 2\text{ °C}$ ) and atmospheric pressure.

In order to evaluate the water flux, the weight loss of the feed solution was acquired over time with a balance (Kern, Germany) placed under the water/sucrose solution tank.

In a first stage the water flux was measured, keeping constant the Reynolds number on the shell side ( $Re_{shell} = 2.16$ ), on which flows deionized water, and varying the Reynolds number on the tube side ( $0.2 < Re < 2.8$ ), for different anhydrous calcium chloride solution concentrations.

In a second stage of the experimental work, the focus was the optimization of the hydrodynamics conditions on the shell side optimization. Here the Reynolds number on the fibres side was kept constant on a value to which the resistance to mass transfer was negligible ( $Re_{fibres} = 0.9$ ) and the water flux was measured raging the Reynolds number on the shell side ( $0.1 < Re < 3.8$ ) where a sucrose solution with different concentration circulated.

The concentration of all solutions was measured with a refractometer (Pal- $\alpha$  pocket, Atago, Tokyo, Japan) and the water activity was measured with a portable water activity indicator (Hygropalm aw, Rotronic). The concentration of the calcium chloride solution was always confirmed according to density tables described in the literature (annex II), as well as the viscosity and water activity of the sucrose solutions (Occidental Chemical Corporation, 2013; Bui & Nguyen, 2004; Karel, Fennema, & Lund, 1975). The measurement of the density of calcium chloride solutions was determined with a pycnometer.

After each experiment, the laboratory setup was cleaned by rinsing both sides with deionised water, measured the rising water conductivity (Schott instruments, Germany) and pH (Crisom, Spain).

## 2.3 Results and Discussion

For the concentration of beverages by the osmotic evaporation process, it is necessary to optimize the hydrodynamic conditions in which the process becomes more efficient, meaning that the contribution of the boundary layers are negligible. For this purpose a series of experiments that enable the study of mass transfer in this process were performed.

### 2.3.1 Optimization of hydrodynamic conditions on the fibres

The flux values obtained increased with the increase of the calcium chloride solution concentration, as shown on the figure 2.4. This happens due to the increase of the driving force; however, no relation between the flux and the Reynolds number was obtained. Nevertheless, the resistance that might occur in fibres can easily be minimized, by determining the calcium chloride solution concentration that favours that situation.

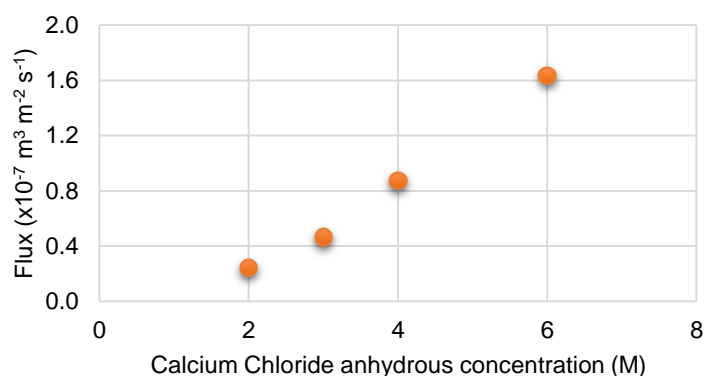

Figure 2.4 Relation between the calcium chloride anhydrous solution and the water flux for OE experiments.

The overall mass transfer coefficient was calculated using equation 2.5, assuming negligible temperature polarization effects, which means that  $P^*_{wt}$  and  $P^*_{ws}$  were calculated using the average temperatures of the bulk (calcium chloride solution and water).

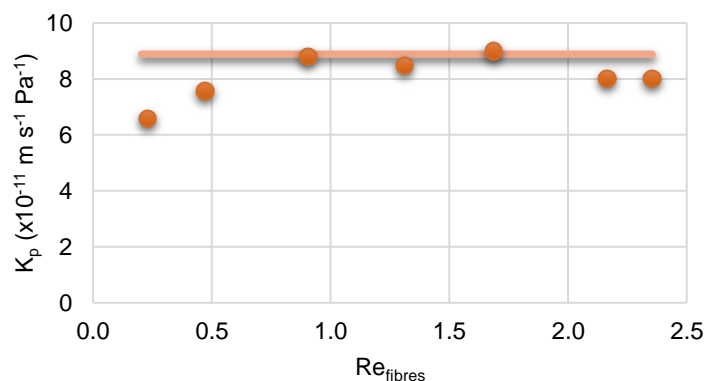

Figure 2.5 Overall mass transfer coefficient for the experiments carried out varying the Reynolds number in the fibres, for different  $\text{CaCl}_2$  solutions (Shell side: deionized water,  $Re = 2.17$ ). Orange line: membrane mass transfer coefficient.

The results presented in the figure 2.5 show a slight increase of the  $K_p$  with the increase of the Reynolds number until it reaches a plateau. The value of this plateau is very similar to the estimated value of the membrane's mass transfer coefficient ( $8.8 \times 10^{-11} \text{m s}^{-1} \text{Pa}^{-1}$ ) by equation 2.6, meaning that the resistance to the mass transfer on the boundary layers is negligible.

For the determination of the  $K_{mp}$  value there was a need to calculate the membrane's tortuosity value, this value may be calculated by  $(\tau=1/\epsilon)$  or  $(\tau=(2-\epsilon)^2/\epsilon)$  depending on whether the porous structure of the membrane is more homogeneous or heterogeneous respectively. In this case, it was concluded that the membrane is heterogeneous because this is the value that coincides with the  $K_p$  obtained experimentally.

### 2.3.2 Optimization of hydrodynamic conditions in the shell side of the module

For the study of the more favourable hydrodynamic conditions on the shell side, it was fixed a Reynolds number equal to 0.9 for the calcium chloride solution that circulated inside the fibres value for which the resistance to the mass transfer is negligible. In this experiment, the Reynolds number on the shell side was varied ( $0.1 < Re < 3.8$ ) through the flow rate variation, as well as the sucrose solution concentration (10% (w/w); 20% (w/w); 45% (w/w)). The flux and the  $K_p$  obtained are represented in figure 2.6 and 2.7 respectively.

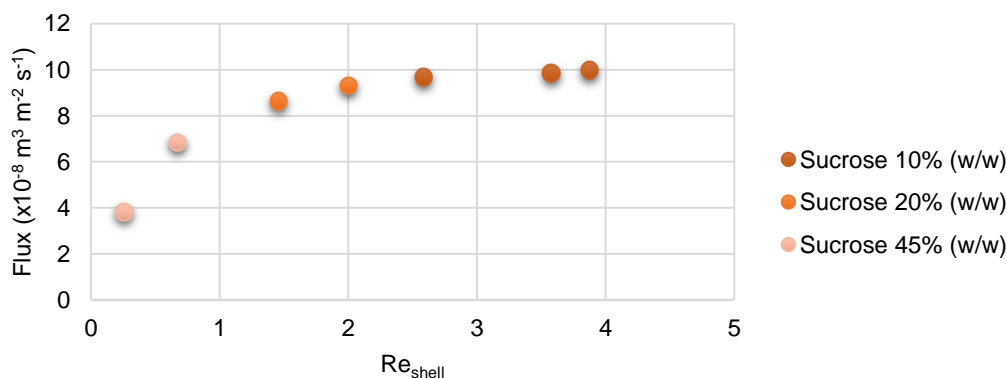

Figure 2.6 Water flux as a function of the Reynolds number in the shell side of the module, for three different sucrose solutions (fibres:CaCl<sub>2</sub> (5M), Re = 0.9)

It can be seen in figure 2.6 that exists a more pronounced variation of the flux with the Reynolds number as the sucrose concentration increased. For the 10% (w/w) sucrose solution, small variation was observed meaning that the resistance to the mass transfer on the boundary layer is practically negligible, since the water flux remains almost constant regardless of the Reynolds number value.

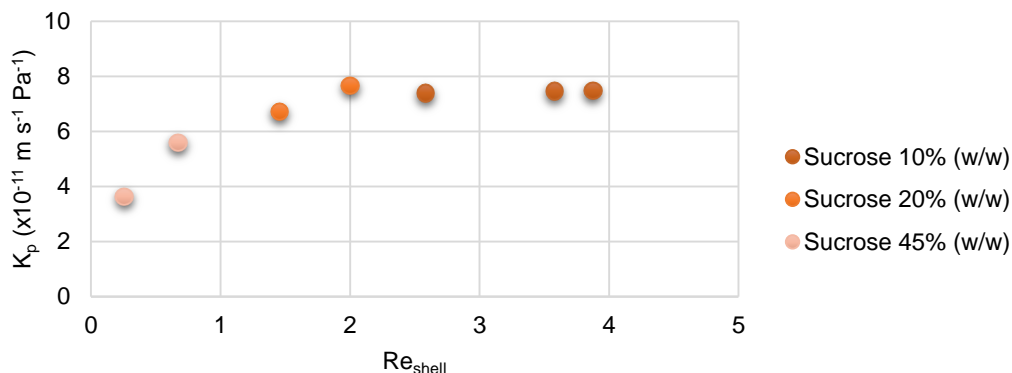

Figure 2.7 Overall mass transfer coefficients for the experiments carried out varying the Reynolds number in the shell side of the module, for three different sucrose solutions (fibres:CaCl<sub>2</sub> (5M), Re = 0.9)

The overall mass transfer coefficient, represented on figure 2.7 shows, as the flux, a high dependence with the Reynolds number, due to the high mass transfer resistance on the membrane's shell side. Still, the obtained  $K_p$  value for this plateau is similar to the value of the membrane's mass transfer coefficient ( $8.8 \times 10^{-11} \text{ m s}^{-1} \text{ Pa}^{-1}$ ), with a deviation of 14%.

### 2.3.3 Mass transfer correlations

Given the experimental conditions used, in which there is a variation in the kinematic viscosity and in the water diffusion coefficient between the experiments, an approach for finding the best correlation of mass transfer for both the fibres and the shell was performed. For this purpose the results obtained were compared with several correlations already obtained by other authors and was selected the ones that best fit the results.

The values of water diffusion coefficients in calcium chloride anhydrous ( $4.1 \times 10^{-10} \text{ m}^2 \text{ s}^{-1} \leq D_w \leq 1.3 \times 10^{-9} \text{ m}^2 \text{ s}^{-1}$ ) and sucrose solutions ( $7.1 \times 10^{-10} \text{ m}^2 \text{ s}^{-1} \leq D_w \leq 2.2 \times 10^{-9} \text{ m}^2 \text{ s}^{-1}$ ) used were obtained from existing literature (Tamas & Ujjaszsy, 1966; Rampp, Buttersack, & Lüdemann, 2000).

Once all laboratory tests were performed at room temperature exists as expected a temperature variation between the inlet and the outlet of the module in each of the phases. Thus, for calculation purposes the average of two temperatures is used.

The correlations used for this study are presented in table 2.1.

#### 2.3.3.1 Fibres mass transfer correlation

The correlation that best describes the mass transfer coefficient in the fibres is the correlation described by Viegas et al ( $Sh=0.2Re^{1.01} Sc^{0.33} (d/L)^{0.33}$ ). It should be noted that this correlation shows a deviation from classical laminar flow, due probably to the non-uniform distribution of the fibres and its possible deformation. These situations will eventually shift the origin of the laminar flow results in irregular flow due to the development of stagnant zones, preferential pathways and deficient mixing (Viegas, et al., 1998).

This correlation was obtained for very low Reynolds numbers, which also happens in the present work. The correlation obtained by Viegas et al. presents an  $\alpha$  parameter equal to 0.2. However, it is

clear that the correlation describes a slower trajectory until the plateau is reached than what was experimentally observed. In this particular case the established correlation was obtained with the increasing of  $\alpha$  parameter from 0.2 to 0.6, enabling to obtain a better fit to the results obtained experimentally (figure 2.8).

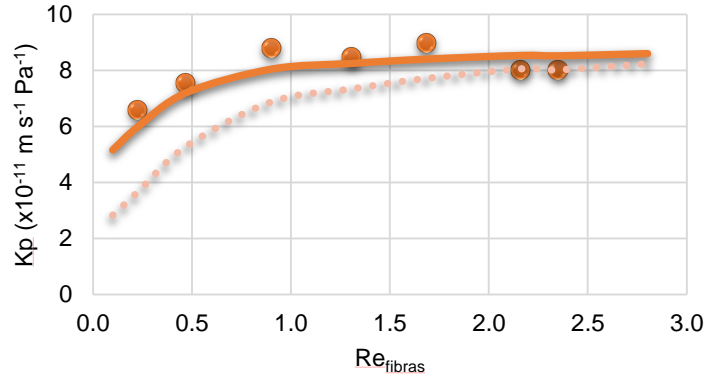

Figure 2.8 Relation between experimental data (points) and the correlation obtained by Viegas et al. (Dashed Line) for the mass transfer coefficient on the fibres side of the module. Correlation with the alteration of  $\alpha$  parameter from 0.2 to 0.6 (Line).

### 2.3.3.2 Shell side mass transfer correlation

The correlation obtained by Yang and Cussler ( $Sh=1.25(Re_dh/L)^{0.93} Sc^{0.33}$ ) is the one that best fits the experimental data. Despite that, this correlation is applied to a high range of Reynolds number, it also can evaluate the mass transfer coefficient for low values of Reynolds similar to those of this work, and describes with high accuracy the experimental results. Nevertheless it was possible to maximize the fit with the alteration of the  $\alpha$  parameter from 1.25 to 0.7 (figure 2.9).

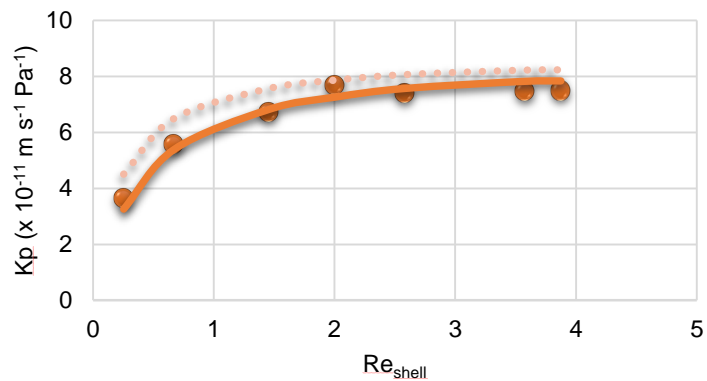

Figure 2.9 Relation between the experimental data (dots) and the correlation obtained by Yang and Cussler (Dashed Line) for the mass transfer coefficient on the shell side of the module. Correlation with the alteration of  $\alpha$  parameter from 1.25 to 0.7 (Line).

## 2.4 Intercalary Remarks

In relation to the fibres side it was noticed that the resistance could be minimized through the selection of factors such as the osmotic agent used, the concentration at which the osmotic agent circulates inside the fibres as well as the flow rate at which the osmotic solution is pumped into the fibres.

Defined the most favourable hydrodynamic conditions in the fibres side, namely those that do not offer additional resistance to the process beyond the membrane resistance, the same procedure was performed, but concerning to the shell side of the module.

In the case of the shell side, it was possible to see that more concentrated sucrose solutions presented more pronounced mass transfer resistance in the boundary layer. In this way, in a concentration process of beverages, the increase of the beverage concentration will be accompanied by the increase of the mass transfer resistance on the shell side of the module.

Yet was possible to determine how could be minimized the resistance of the shell side and thus determine the most favourable hydrodynamic conditions to operate the osmotic evaporation process.

The mass transfer correlations for the two sides of the membrane were obtained by comparison with other correlation obtained by different authors and although the fitting is not perfect, it can be assumed that the correlations obtained describe the mass transfer coefficients with significant accuracy.

Mass transfer correlation for the tube side:  $Sh=0.6Re^{1.01} Sc^{0.33} (d/L)^{0.33}$

Mass transfer correlation for the shell side:  $Sh=0.7(Re_d h/L)^{0.93} Sc^{0.33}$

## 2.5 References

- Alves, V. D., & Coelho, I. M. (2002). Mass transfer in osmotic evaporation: effect of process parameters. *Journal of Membrane Science*, 208, 171-179.
- Alves, V. D., & Coelho, I. M. (2004). Effect of membrane characteristics on mass and heat transfer in the osmotic evaporation process. *Journal of Membrane Science*, 228, 159-167.
- Alves, V. D., Koroknai, B., Bélafi-Bakó, K., & Coelho, I. M. (2004). Using membrane contactors for fruit juice concentration. *Desalination*, 162, 263-270.
- Alves, V. D., & Coelho, I. M. (2007). Study of mass and heat transfer in the osmotic evaporation process using hollow fibre membrane contactors. *Journal of Membrane Science*, 289, 249-257.
- Bailey, A. F. G., Barbe, A. M., Hogan, P. A., Johnson, R. A., & Sheng, J. (2000). The effect of ultrafiltration on the subsequent concentration of grape juice by osmotic distillation. *Journal of Membrane Science*, 164, 195-204.
- Bui, A. V., & Nguyen, M. H. (2004). Prediction of viscosity of glucose and calcium chloride solutions. *Journal of Food Engineering*, 62, 345-349.
- Bui, A. V., Nguyen, H. M., & Joachim, M. (2005). Characterisation of the polarisations in osmotic distillation of glucose solutions in hollow fibre module. *Journal of Food Engineering*, 68, 391-402.
- Cassano, A., Drioli, E., Galaverna, G., Marchelli, R., Silvestro, G. D., & Cagnasso, P. (2003). Clarification and concentration of citrus and carrot juices by integrated membrane processes. *Journal of Food Engineering*, 57, 153-163.
- Cassano, A., Conidi, C., & Drioli, E. (2010). Physico-chemical parameters of cactus pear (*Opuntia ficus-indica*) juice clarified by microfiltration and ultrafiltration processes. *Desalination*, 250, 1101-1104.
- Courel, M., Dornier, M., Herry, J. M., Rios, G. M., & Reynes, M. (2000). Effect of operating conditions on water transport during the concentration of sucrose solutions by osmotic distillation. *Journal of Membrane Science*, 170, 281-289.
- Courel, M., Tronel-Peyroz, E., Rios, G. M., Dornier, M., & Reynes, M. (2001). The problem of membrane characterization for the process of osmotic distillation. *Desalination*, 140, 15-25.
- Gabelman, A., & Hwang, S. (1999). Hollow fiber membrane contactors. *Journal of Membrane Science*, 159, 61-106.
- Gawronski, R., & Wrzesinska, B. (2000). Kinetics of solvent extraction in hollow-fiber contactors. *Journal of Membrane Science*, 168, 213-222.
- Godino, M. P., Pena, L., Ortiz de Zárate, J. M., & Mengual, J. I. (1995). Coupled phenomena membrane distillation and osmotic distillation through a porous hydrophobic membrane. *Separation Science and Technology*, 30, 993-1011.
- Gökmen, V., Serpen, A., & Fogliano, V. (2009). Direct measurement of the total antioxidant capacity of foods: the "QUENCHER" approach. *Trends in Food Science & Technology*, 20, 278-288.
- Karel, M., Fennema, O. R., & Lund, D. B. (1975). *Principles of food science. Part II. Physical principles of food preservation*. New York, USA: Marcel Dekker, Inc.
- Kunz, W., Benhabiles, A., & Ben-Aïn, R. (1996). Osmotic evaporation through macroporous hydrophobic membranes: a survey of current research and applications. *Journal of Membrane Science*, 121, 25-36.

Lefebvre, M. S. (1988). *U.S. Patent No. 4,781,837*. Washington, DC: U.S. Patent and Trademark Office.

Martins, F. L. (2006). Desenvolvimento experimental, modelagem e simulação do processo de evaporação osmótica para concentração de soluções de sacarose contendo aroma de frutas tropicais. Tese de Doutorado em Engenharia Química, Universidade Federal do Rio de Janeiro, Brasil.

Michaels, A. S., Hill, C., & Johnson, R. J. (1998). *U.S. Patent No. 5,824,223*. Washington, DC: U.S. Patent and Trademark Office.

Occidental Chemical Corporation. (October 1, 2013). *Calcium Chloride: Physical properties guide*. Obtained of Oxicalciumchloride:

<http://www.oxy.com/OurBusinesses/Chemicals/Products/Documents/CalciumChloride/173-01791.pdf>

Oliveira, A. C. (2011). Caracterização química, avaliação da atividade antioxidante in vitro e atividade antifúngica de pimentas do género *Capsicum* spp. Tese de Mestrado em Alimentos e nutrição, Universidade Federal do Piauí, Brasil.

Poling, B.E., Prausnitz, J.M., & O'Connell, J.P. (2001). *The Properties of Gases and Liquids*. 5th ed. New York: McGraw-Hill.

Rampp, M., Buttersack, C., & Lüdemann, H. (2000). *c, T-Dependence of viscosity and the self-diffusion coefficients in some aqueous carbohydrate solutions*. *Carbohydrate Research*, 328, 561-572.

Sheng, J., Johnson, R. A., & Lefebvre, M. S. (1991). Mass and heat transfer mechanisms in the osmotic distillation process. *Desalination*, 80, 113-121.

Tamas, J., & Ujjaszky, K. (1966). Diffusion of H<sub>2</sub><sup>18</sup>O molecules in certain aqueous salt solutions. *Magyar Kémiai Folyóirat*, 72, 447.

Vaillant, F., Jeanton, E., Dornier, M., O'Brien, G. M., Reynes, M., & Decloux, M. (2001). Concentration of passion fruit juice on an industrial pilot scale using evaporation. *Journal of Food Engineering*, 47, 195-202.

Viegas, R. M. C., Rodríguez, M., Luque, S., Alvarez, J. R., Coelho, I. M., & Crespo, J. P. S. G. (1998). Mass transfer correlations in membrane extraction: Analysis of wilson-plot methodology. *Journal of Membrane Science*, 145, 129-142.



## Chapter 3

---

# Study of Teas Concentration Process



### 3.1 Introduction

Tea is one of the most consumed beverages in the world and the oldest beverage produced by man, since around century 27 B.C. (Morais, Cavalcanti, Costa, & Aguiar, 2009). The consumption of tea represents about 20% of world consumption of beverages and occurs mainly in the form of infusion (Neves, et al., 2010).

The world production of tea has increased more than consumption, so there is the need to improve product quality and to find innovative ways of processing and distribution of this product (Lima, Mazzafera, Moraes, & Silva, 2009). In this context, soluble powder tea has been produced, which can be consumed as instant soluble herbal tea as well as a pharmaceutical product (Torun, et al., 2014). China is one of the countries with the highest consumption of tea and with the higher research focus in this field. It presents a strong industrial activity in the concentration process of teas, with an annual production of about fifteen thousand tons of concentrated tea with a concentration of 60 ° Bx. (Xu, Chen, Yuan, Tang, & Yin, 2012). Torun, et al. (2014) are the first authors to publish results of tea concentration through an integrated membrane process using also osmotic evaporation to obtain a final concentration of 32.4 % (w/w).

At an industrial level, tea aqueous extract initially passes through an aroma stripping step, followed by concentration with thermal evaporation at low pressure. For the production of powder tea, the concentrated is dried by spray drying (Torun, et al., 2014). However, it is known that thermal treatments lead to a considerable loss of heat-sensitive bioactive compounds, which are present in tea.

As an alternative to thermal evaporation processes, arise the membrane processes, including osmotic evaporation, which achieve high concentrations operating at ambient pressure and temperature, enabling the removal of water with a much lower loss of bioactive components.

There are distinguished four main types of tea based on the oxidative process that are subjected to: (i) White tea; (ii) Green tea; (iii) Oolong tea; (iv) Black tea, in ascending order of the degree of oxidation. All the four types are produced from leaves of *Camellia sinensis* (Ruan, Wu, & Hårdter, 1999). The large consumption of tea is explained by its aroma and antioxidant potential.

Antioxidants are compounds that delay the onset of oxidative changes that occur at the cellular level. The oxidation of biological systems takes place naturally due to the development of free radicals, which are formed by both exogenous and endogenous reasons (Soares, 2002).

The formation of such radicals can cause an imbalance between the release of reactive oxygen species and the capacity of antioxidant defence systems resulting in oxidative stress and destruction of unsaturated lipids, DNA, proteins, thereby leading to the development of various diseases (Sun, Chu, Wu, & Liu, 2002; Gliszczynska-Swiglo, 2006). The antioxidants can be classified into two groups, enzymatic antioxidants and nonenzymatic antioxidants (Sies, 1997).

Generally, the important antioxidant potential present in most teas results from their content in phenolic compounds, chemical structures critical in the absorption and neutralization of free radicals

(Ramalho & Jorge, 2006). Regarding the vitamins present in tea, may be mention riboflavin (vitamin B2), which is stable during the processing of tea, and ascorbic acid (vitamin C) which is quite unstable and rapidly oxidized (Lima, Mazzafera, Moraes, & Silva, 2009).

The teas studied in this work were: (i) medicinal Rosil N° 6 tea; (ii) black tea; (iii) forest fruit tea. Their main ingredients are presented on table 3.1.

The medicinal Rosil N° 6 tea consists of several plant species, all with key components in the regulation of gastrointestinal function. This tea has fundamentally high content of polyphenols, protein and vitamin A.

Black tea is produced from the leaves of *Camellia sinensis*, which is cultivated in more than 30 countries. This tea represents near 80% of tea consumption in the world (Lima, Mazzafera, Moraes, & Silva, 2009). In the production of black tea, catechins are enzymatically oxidized, forming flavonol dimers and polymers known as theaflavins (colour and brightness red-orange) and thearubigins (rust-brown staining) respectively (Frei & Higdon, 2003). Amongst flavonols, quercetin and myricetin are components that are present only in black tea infusions (Pekal, Drózd, Biesaga, & Pyrzynska, 2011).

The forest fruit tea is a flavoured black tea with added aromas and dry fruits or herbs to tealeaves in the last stage of processing before packing (Pekal, Drózd, Biesaga, & Pyrzynska, 2011). Flavoured black teas contain a significantly higher level of catechins, quercetin and rutin and are also rich in anthocyanins, preventing lipid oxidation and scavenging activity against various free radicals (Kähkönen, Hopia, & Heinonen, 2001; Pekal, Drózd, Biesaga, & Pyrzynska, 2011).

Chapter 3 is dedicated to the study of the osmotic evaporation process as a potential technology to the concentration of teas. After the concentration essays, the total phenolic content and antioxidant activity were evaluated, in order to assess the effect of the osmotic evaporation process.

Table 3.1 Main ingredients of teas

Tea	Ingredients
<b>Medicinal Rosil N° 6 tea</b>	Avocado ( <i>Persea americana</i> )
	Boldo ( <i>Peumus boldus</i> )
	Gorse flower ( <i>Genista tridentata</i> )
	Horsetail ( <i>Equisetum giganteum</i> )
	Herb Robert ( <i>Geranium robertianum</i> )
	St John's weed ( <i>Hypericum perforatum</i> )
	Dandelion ( <i>Taraxacum officinale</i> )
<b>Black tea</b>	Camellia Sinensis ( <i>Camellia sinensis</i> )
	Camellia Sinensis ( <i>Camellia sinensis</i> )
<b>Forest Fruit tea</b>	Raspberry ( <i>Rubus idaeus</i> )
	Cherry ( <i>Prunus</i> )
	Blackberry ( <i>Morus</i> )
	Redcurrant ( <i>Ribes rubrum</i> )

## 3.2 Experimental

### 3.2.1 Extraction process of teas

Commercial black tea (tea bags, Lipton), forest fruit tea (tea bags, Lipton), and medicinal Rosil N° 6 tea (dried leaves), the later donated by herbal Rosil were used.

The extraction process of teas was performed according to the manufacturer's indications. Regarding black and forest fruit teas, the bags supplied from the market were opened, and the content was weighed. The masses ranged between 1.64 - 2.02 g per bag. The content of one bag was added to 200 ml of water; and the infusion time was 2 minutes and 30 seconds in boiling water (100 °C). The obtained extract was cooled to room temperature. The extracts soluble solids concentration were 0.3 °Bx and 0.2 °Bx respectively. The medicinal Rosil N° 6 tea extract was obtained by adding 8.15 g of dry leaves to 1000 ml of water, and boiling for 5 minutes after which it were allowed to infuse for 2 minutes. The obtained extract was cooled to room temperature and subsequently filtered with filter paper. The soluble solids concentration was 0.3 °Bx. The soluble solids concentration was determined using a refractometer (Pal- $\alpha$  pocket, Atago, Tokyo, Japan).

### 3.2.2 Concentration process by OE

The obtained tea extracts were processed using a laboratory setup (figure 2.3) equipped with a hollow fibre membrane contactor (1.7 x 55 MiniModule) with an effective surface area of 0.54 m<sup>2</sup>. This membrane contactor contains 7400 polypropylene fibres (Celgard X50-215 Microporous Hollow Fibre Membrane) with a nominal pore size of 0.04  $\mu$ m, 40% porosity, 18 cm long, an internal diameter of 220  $\mu$ m and a thickness of 40  $\mu$ m.

The tea was recirculated in the shell side of the membrane module and a calcium chloride anhydrous solution 5 M (Panreac, Spain) recirculated in the lumen of the fibres in a counter-current mode ( $Re_{fibres} = 0.9$  and  $Re_{shell} = 2.6$ ).

The initial volume of the osmotic solution was 8000 ml in each experimental run. Calcium chloride was not added to the osmotic solution during the process. Inlet and outlet pressures of both tube side and shell side were monitored ( $P_{shell_{in}} = 0.15$  bar;  $P_{shell_{out}} = 0$  bar;  $P_{fibres_{in}} = 0.3$  bar;  $P_{fibres_{out}} = 0$  bar) as well as the inlet temperature (20 °C  $\pm$  2 °C). The temperature profiles during the concentration processes are described in annex III.

In order to evaluate the water flux, the weight loss of the tea vessel, with an initial tea volume of 1000 ml, was measured over time with a balance (Kern, Germany).

After each experiment, the laboratory setup was cleaned by rinsing both sides with deionised water.

### 3.2.3 Total Solids determination

The total solids (TS) content was determined by evaporating 100 ml of each tea extract in a rotary evaporator (T = 40 °C and 55 < P < 70 mbar).

At the end of the total water evaporation, the concentration of TS was determined by weight and reported in g TS /g solution.

#### 3.2.4 Total phenolic content

The total phenolic content was determined using the Folin-Ciocalteu method, in which the polyphenols react with the Folin reagent forming a blue dye (Swain & Hillis, 1959). Firstly, a solution of Folin-Ciocalteu reagent 0.25 M was prepared. Then, a volume of 150  $\mu\text{L}$  of this reagent was added to 150  $\mu\text{L}$  of sample and 2.4 ml of nanopure water. The test tubes containing this mixture were stirred with a vortex, the reaction took place for 3 minutes, after which 300  $\mu\text{L}$  of 1M  $\text{Na}_2\text{CO}_3$  was added to each tube. Then the test tubes were shaken and allowed to react for 2 hours in the dark, after which the absorbance was measured in the spectrophotometer (Unican UV/Vis) at a wavelength of 725 nm. When necessary dilutions of samples were performed. The results were reported to the mass of total solids present in each sample and are expressed in g GAE/ g TS.

All the samples were analysed in triplicate with each of the tea samples taken every two hours and the start and end of each beverage sample. The data presented are the average of triplicates. The calibration curve for the Folin-Ciocalteu method are present in annex IV.

#### 3.2.5 Antioxidant Activity

The FRAP method was performed according to the method of Benzie & Strain, (1996); however, some changes were introduced. The following stock solutions were prepared: (i) acetate buffer, pH 3.6; (ii) 10 mM TPTZ solution; (iii) 20 mM ferric chloride aqueous solution; (iv) 40 mM HCl.

The FRAP reagent solution is obtained by mixing 25 ml of acetate buffer, pH 3.6, 2.5 ml of TPTZ solution 10 mM and 2.5 ml of ferric chloride aqueous solution 20 mM. This solution should be prepared immediately before being used. A volume of 2.7 ml of the FRAP reagent solution is mixed with 270  $\mu\text{L}$  of nanopure water, to which an aliquot of 90  $\mu\text{L}$  of each of the samples is added. The samples are placed in the dark for 30 minutes in a water bath at  $T = 37^\circ\text{C}$ . The absorbance of the samples is measured at 595 nm using the spectrophotometer (Unican UV/Vis). When necessary dilution of the samples was performed. The results were reported to the mass of total solids present in each sample and are expressed in g ferrous sulphate/g TS.

The DPPH (2,2-diphenyl-1-picryl-hidrazil) method was performed with reference to the method of Brand-Williams, Cuvelier, & Berset, (1995). A stock solution was prepared by dissolving 24 mg of DPPH in 100 mL of methanol, which was stored at  $-20^\circ\text{C}$  for at least 2 hours. The working solution, required for application of the method, was prepared by dilution of the stock solution in methanol at a ratio of (10:45). The absorbance of this solution was measured at 517 nm in spectrophotometer (Unican UV/Vis), which should not exceed the value 1.1. Afterwards, an aliquot of 150  $\mu\text{L}$  of tea samples was added to 4 ml of the working solution and stored in the dark for 40 minutes, so that the antioxidants present in the sample react with the radical. After this time the absorbance of all samples was measured

at 517 nm. When necessary dilution of the samples were performed. The results were reported to the mass of total solids present in each sample and are expressed in  $\mu\text{M TE}/\mu\text{g TS}$  (TEAC).

All the samples were analysed in triplicate with each of the tea samples taken every two hours and the start and end of each beverage sample. The data presented are the average of triplicates. The calibration curves for the FRAP and DPPH methods are present in annex IV.

### 3.2.6 Colour analysis

Colour values were evaluated by CIELAB colour space (illuminant D65/10° observer) on Unicam UV/Vis spectrophotometer with Chroma Colour Measurement Software, V 2.0, Unicam (Hungary).

Two measurements were made on each of the nine samples (initial teas, concentrated final teas and reconstituted teas) and the variation in percentage reflectance values over a range of 380 - 770 nm was recorded. After these measurements the colour differences ( $\Delta E$ ) were calculated.

### 3.3 Results and Discussion

#### 3.3.1 Concentration process by OE

The evaluation of the osmotic evaporation process itself involves the analysis of the water flux, driving force and overall mass transfer coefficient.

Figure 3.1 shows the permeate flux over time, for the three tea experiments, from which it may be seen that there in general, there were low changes in the permeate fluxes over time.

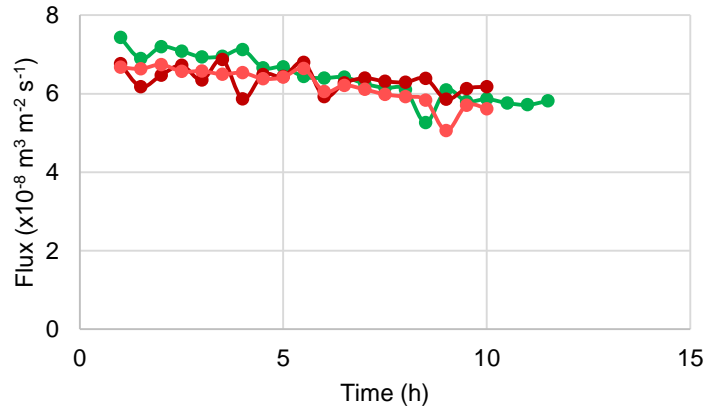

Figure 3.1. Water flux as a function of the time. Green – Medicinal Rosil N° 6 tea; Brown – Black tea; Pink – Forest Fruit tea.

Medicinal Rosil N° 6 tea registered a decrease of about 22%, more pronounced after the 4<sup>th</sup> hour of the concentration process, while the water flux for the forest fruit tea decreased 16% and for the case of black tea the water flux decrease only 8.8% (table 3.2).

Table 3.2 Initial and final permeate fluxes during tea concentration process

	Initial flux $\text{m}^3 \text{ m}^{-2} \text{ s}^{-1}$	Final flux $\text{m}^3 \text{ m}^{-2} \text{ s}^{-1}$
<b>Medicinal Rosil N° 6 tea</b>	$7.44 \times 10^{-8}$	$5.82 \times 10^{-8}$
<b>Black tea</b>	$6.76 \times 10^{-8}$	$6.18 \times 10^{-8}$
<b>Forest Fruit tea</b>	$6.67 \times 10^{-8}$	$5.62 \times 10^{-8}$

Regarding the overall mass transfer coefficient,  $K_p$  (figure 3.2) it is possible to observe that for all the teas it remained constant throughout the experiment. This fact indicates a negligible variation of the overall mass transfer resistance. As such, the small decrease of the water flux is not due to mass transfer limitations.

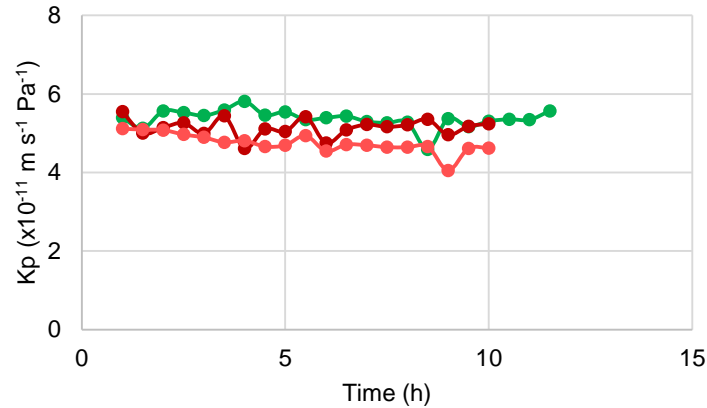

Figure 3.2 Overall mass transfer coefficient as a function of the time. Green – Medicinal Rosil N° 6 tea; Brown – Black tea; Pink – Forest Fruit tea.

Table 3.3 Average of the overall Mass transfer coefficients ( $10^{-11} \text{ m}^{-1} \text{ s}^{-1} \text{ Pa}^{-1}$ ) for each tea during the OE process

<b>Medicinal Rosil N° 6 tea</b>	$5.37 \pm 0.23$
<b>Black tea</b>	$5.14 \pm 0.23$
<b>Forest Fruit tea</b>	$4.75 \pm 0.25$

The value of the overall mass transfer coefficient of all the teas concentration processes was lower than the mass transfer coefficient of the membrane evaluated in chapter 2 ( $8.88 \times 10^{-11} \text{ m}^{-1} \text{ s}^{-1} \text{ Pa}^{-1}$ ) (table 3.3). This fact indicates the existence of mass transfer resistance in the boundary layers adjoining the membrane. This resistance is more likely to arise from the boundary layer of the shell side where the tea is circulating. The cause of the decrease of the overall mass transfer coefficient is possibly the deposition near the membrane of molecules and components in suspension in the teas. In addition, the random distribution of the fibres in the module, as well as the possibility of deformation, may have led to the formation of stagnant zones and preferential fluid paths (Onsekizoglu, Bahceci, & Acar, 2010).

The driving force value over time for each concentration process is presented in figure 3.3. It can be observed a decrease tendency, which is in line with the evolution of the water flux. The decline of the flux may be mainly attributed to the dilution of osmotic agent and to the concentration of tea extract over time, similar to the results obtained by Cassano, et al., (2003); Cassano, Conidi, & Drioli, (2010) and Torun, et al., (2014). The dilution of the osmotic agent led to the decrease of the water vapour pressure of the osmotic solution, which resulted on the decrease of driving force for water transport.

Another factor inherent to the variation of the driving force that certainly influenced the process is the temperature profile of each experimental run that can vary within a reasonable range considering that the tests were performed at room temperature without temperature control (annex III) (Gostoli, 1999; Alves & Coelho, 2004; Bui, Nguyen, & Joachim, 2005; Alves & Coelho, 2007).

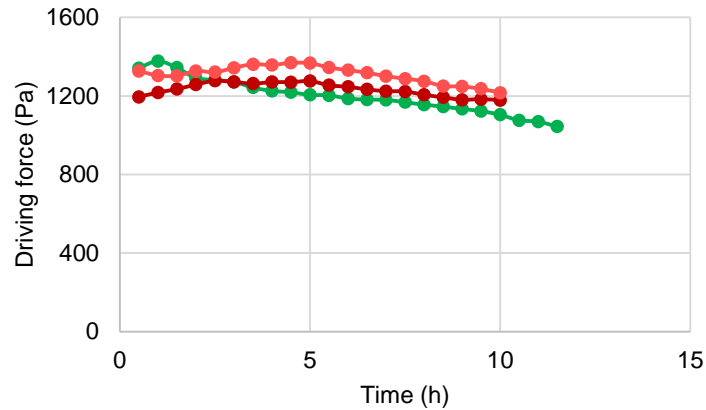

Figure 3.3. Driving force as a function of the time. Green – Medicinal Rosil N° 6 tea; Brown – Black tea; Pink – Forest Fruit tea.

### 3.3.2 Evaluation of teas concentration

Throughout the concentration process there was an increase of the total solids for the teas (figures 3.4; 3.5; 3.6). Comparing the values, based on 10 hours of test, the forest fruit tea corresponded to the tea with largest TS, both initial and final, and the medicinal Rosil N° 6 tea was the one that showed the smallest amount of total solids, both initial and final. This data must probably be related to the types of tea used. Both black tea and forest fruit tea were Lipton tea bags, whereas the medicinal Rosil N° 6 tea was an herbalist tea that after the infusion process was filtrated so that the suspended solids would not interfere with mass transfer. However, it is important to refer that analysing the increase of the TS there was an increase of 3.6 times from the initial TS for the medicinal Rosil N° 6 tea, while black and forest fruit teas had an increase of 3.4 and 3.2 times respectively. These data may be due to the increase of the resistance to mass transfer from test to test, whereas the tests were realized by the following order: (i) medicinal Rosil N° 6 tea; (ii) black tea; (iii) forest fruit tea.

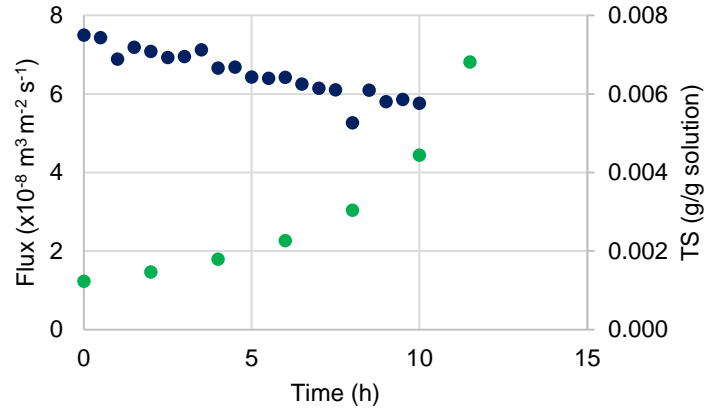

Figure 3.4 Variation of the water flux and total solids content (TS) through the concentration process to the Medicinal Rosil N° 6 tea. Blue – Water flux. Green - TS.

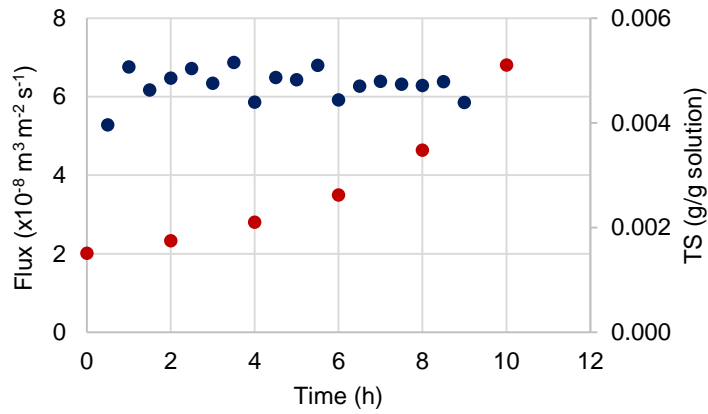

Figure 3.5. Variation of the water flux and total solids content (TS) through the concentration process to the Black tea. Blue – Water flux. Brown - TS.

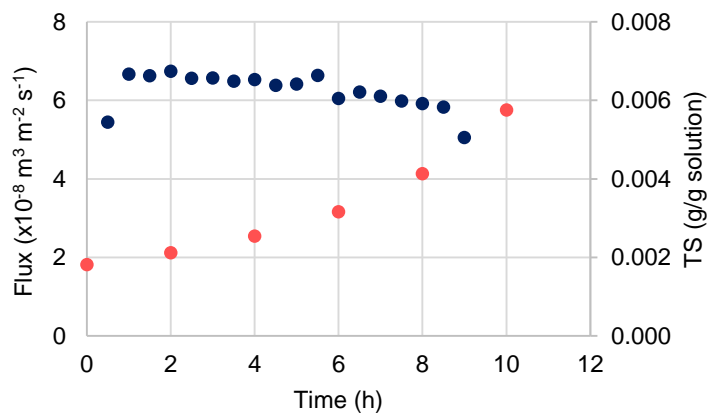

Figure 3.6. Variation of the water flux and total solids content (TS) through the concentration process to the Forest Fruit tea. Blue – Water flux. Pink - TS.

### 3.3.3 Antioxidant activity and phenolic content

The antioxidant activity was determined during the concentration process using two methods, radical scavenging activity (DPPH) and ferric reducing antioxidant power (FRAP), by reacting beverages samples collected during the concentration process with the DPPH radical or FRAP reagent. In addition, the content of total phenols was evaluated, and a comparative study between the total phenolic content and antioxidant activity was performed.

#### 3.3.3.1 Total phenolic content

Figure 3.7 shows a decrease of total phenolic content for medicinal Rosil N° 6 and black teas, while for the black tea this decline was observed only after 6 h of processing, decreasing thereafter until the end of the experiment, registering a percentage of phenols loss of 24.78%. The medicinal Rosil N° 6 tea showed a very similar behaviour, since in the first 6 hours only 8.38% of total phenols were lost, while on the test time comprised between 6 and 10 hours a greater loss of phenols is observed, resulting in a total loss (for 10 hours) of 27.26%.

The decrease in the phenolic content for long processing times (more than 6 hours) may be attributed to degradation of these compounds. Regarding forest fruit tea, there was no decrease of the total phenolics over time.

Several authors evaluated the phenolic content of different teas. The results obtained in this work are generally lower than those obtained in other studies (0.2 – 0.4 g GAE/ g TS) (Pekal, Drózd, Biesaga, & Pyszynska, 2011; Torun, et al., 2014). These differences are due to the different plants used to produce the teas. In addition, when the same plant material is used, the differences in the phenolic composition may arise from the year and local of plants harvest.

It's importante to refer that if the process is carried out in two hours it is expected the retention of 94% to 100% of the phenolic content, as obtained by Torun, et al., (2014) for tea extracts.

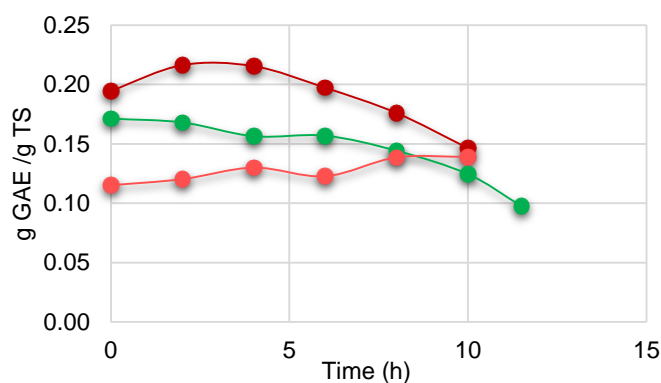

Figure 3.7 Total phenolic content through the concentration process. Brown – Black tea; Green – Medicinal Rosil N° 6 tea; Pink – Forest Fruit tea.

### 3.3.3.2 Antioxidant activity

From the analysis performed by the DPPH test (figure 3.9), a decrease of the antioxidant activity for medicinal Rosil N° 6 and black tea of 29.58% and 52.47% respectively was reported, referring to 10 hours of concentration. On the other hand, the forest fruit tea maintained the antioxidant activity during the concentration process. In what concerns to the analysis realized by the FRAP method (figure 3.8), it was observed a decrease on the antioxidant activity of 29.56% and 33.31% for the medicinal Rosil N° 6 tea and the Black tea respectively.

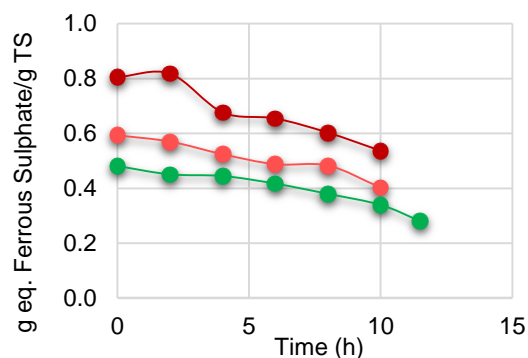

Figure 3.8. Antioxidant activity through concentration process by FRAP method. Brown – Black tea; Pink – Forest Fruit tea; Green – Medicinal Rosil N° 6 tea.

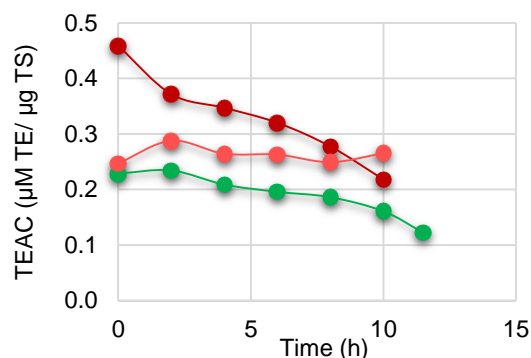

Figure 3.9. Antioxidant activity through concentration process by DPPH method. Brown – Black tea; Pink – Forest Fruit tea; Green – Medicinal Rosil N° 6 tea.

However when analysing the forest fruit tea it shows a decrease of 32.00% of the antioxidant activity, which contradicts the results obtained on the DPPH method. This happens because of the chemical reactions that occur in each of the methods (Ozgen, Reese, Tulio JR., Scheerens, & Miller, 2006; Gülçin, 2012). In what concerns to the FRAP method not all the compounds able to reduce  $F^{3+}$ -TPTZ (ferric-tripyridyltriazine) to the ferrous form ( $F^{2+}$ -TPTZ) are antioxidants, and not all the antioxidants have the ability to reduce these complexes (Vasconcelos, et al., 2007). Despite this discrepancy, DPPH method was already cited as an efficient method to measure the antioxidant activity of forest fruit tea (Pekal, Drózd, Biesaga, & Pyrzynska, 2011).

The registered oscillations during the concentration process referring to the antioxidant activity in a certain moment might be due to the transformation of antioxidant compounds in others that might have higher or lower antioxidant activity than the group of antioxidant compounds at the initial moment.

From figures 3.8 and 3.9 it is noticeable that the black tea presents a higher antioxidant capacity, the medicinal Rosil N° 6 tea is the one that show less antioxidant capacity on the initial sample, having only about 50% of the antioxidant activity present on black tea. The forest fruit tea was the one in which antioxidant activity was maintained similar after the concentration process according to the DPPH method. It seems that the antioxidants present on the forest fruit tea are more stable than those present in the other teas.

It is noteworthy that the black tea is initially a dark coloured tea that with the concentration process becomes even more pronounced. On the other hand, black tea has in its composition complex molecules. Both of the referred factors can eventually interfere on the spectrophotometric analysis and

difficult the reading especially when the most concentrated samples are analysed (Gülçin, 2012). Therefore, the decrease of the antioxidant activity can be discussed for this tea.

Many of the factors that contributed to the decrease of antioxidant activity in this process at a laboratory scale (ex. light and oxygen interference; concentration process time) need to be minimized, if the osmotic evaporation process is performed at an industrial scale.

Taking into account the results obtained it is evident that during the first two hours of processing no significant variation of antioxidant activity and total phenols was perceived, so it would be interesting to set up a contactor with a membrane area that enables the production of a concentrated beverage, in less than two hours.

### 3.3.3.3 Relation between antioxidant activity and total phenol content

According to the literature, there is a strong relation between phenolic content and antioxidant activity, especially in plant extracts (Luís, Domingues, Gil, & Duarte, 2009). Thus, the study of this relation was made in concentrated teas.

It is possible to verify that the phenols content determined by Folin-Ciocalteu method correlates with the antioxidant activity for medicinal Rosil N° 6 tea and black tea, confirming that phenols are likely to contribute to the radical scavenging activity (figures 3.10; 3.11; 3.12; 3.13). Similar results have been reported by Turkmen, Sari, & Velioglu, (2006).

However a negative relation was obtained for the forest fruit tea with the antioxidant activity determined by the FRAP method (figure 3.14). Results similar to this one were also reported by Kähkönen, et al., (1999) for plant extracts, indicating that different phenolic compounds have different responses in the Folin-Ciocalteu method, as such, molecular antioxidant response of phenolic compounds varies depending on their chemical structure.

When correlating antioxidant activity (DPPH) with phenolic content (figure 3.15) it can be seen constant TEAC with increasing phenolic content. A possible explanation is the interference of anthocyanins present in the forest fruit tea, which absorb at a wavelength between 400-600 nm (Merzlyak, Chivkunova, Solovchenko, & Naqvi, 2008). Nevertheless, the variation of phenolic content is lower for this tea, from which it could be expected a small variation of the antioxidant activity.

This situation leads to the conclusion that phenolic content confers the majority of the antioxidant potential in medicinal Rosil N° 6 tea and black tea. On the contrary, for the forest fruit tea the relation between antioxidant activity and phenolic content is not so evident.

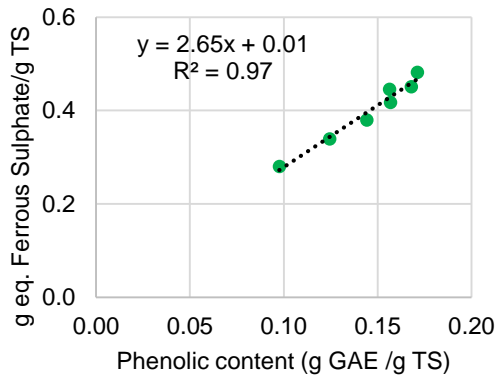

Figure 3.10 Relation between phenolic content and antioxidant activity (FRAP) to the medicinal Rosil N° 6 tea

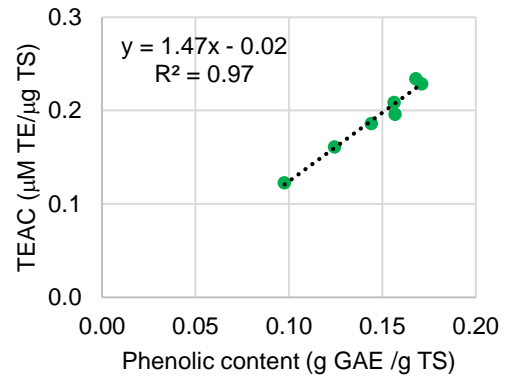

Figure 3.11 Relation between phenolic content and antioxidant activity (DPPH) to the medicinal Rosil N° 6 tea

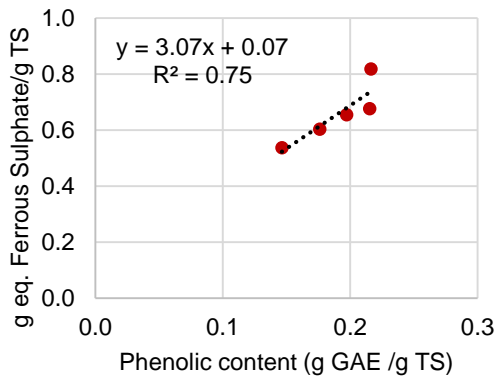

Figure 3.12 Relation between phenolic content and antioxidant activity (FRAP) to the Black tea

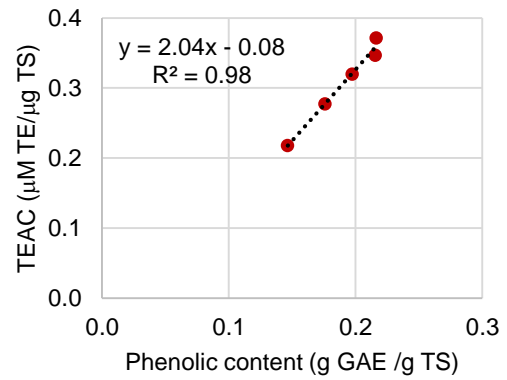

Figure 3.13 Relation between phenolic content and antioxidant activity (DPPH) to the Black tea

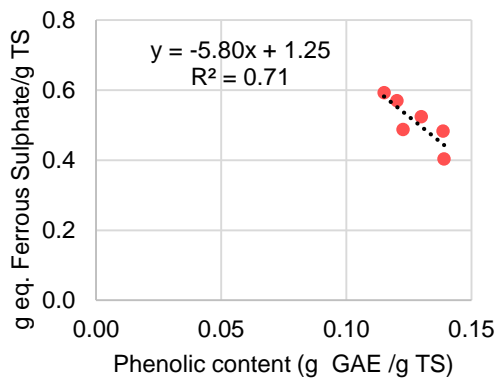

Figure 3.14 Relation between phenolic content and antioxidant activity (FRAP) to the Forest Fruit tea

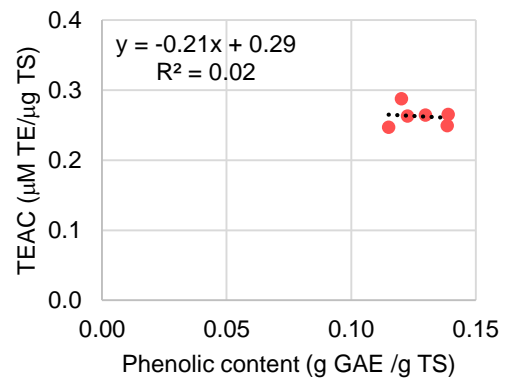

Figure 3.15 Relation between phenolic content and antioxidant activity (DPPH) to the Forest Fruit tea

### 3.3.4 Colour analysis

Each colour is defined based on three characteristics, hue, chroma and lightness. The hue is the notion that the observer has of the object's colour, the chroma describes the vividness or dullness of the colour, also known as saturation and the lightness is the luminous intensity of the determinate colour.

The *Commission Internationale de l'Éclairage* created a colour system based on the product of a particular illuminant, observer and numerical values, which together describe a particular colour. This system uses three coordinates (CIE XYZ, CIE LAB, CIE LCH) to find the colour in a colour space diagram (X-RITE, 2007).

L \* defines lightness, with L = 0 corresponding to the total absorption of the colour; a \* the red / green value, representing the movement a+ displacement to the red; b \* the yellow / blue value, corresponding to b+ displacement toward yellow; C \* represents the chroma and angle h° the hue.

The comparison between two or more colours is usually important in sensory analysis. The difference between colours is given by the following expression:

$$\Delta E_{ab}^* = [(\Delta L^2) + (\Delta a^2) + (\Delta b^2)]^{1/2}$$

The results in table 3.4 refer to the colour difference before and after concentration process ( $\Delta E_{I;F}^*$ ) as well as the colour difference between concentrate tea reconstituted to the initial concentration and the colour of the tea before the concentration process ( $\Delta E_{I;R}^*$ ).

The  $\Delta E_{I;F}^*$  value analysis showed that the teas had distinct differences in colour. Medicinal Rosil N° 6 tea had a superior difference of colours before and after the concentration process, followed by black tea and subsequently the forest fruit tea. The difference between the initial and final colour was related to the different reactions that occur between the compounds present in teas, which are clearly different depending on the tea.

The value of  $\Delta E_{I;R}^*$  has greater importance to the sensory acceptance. The medicinal Rosil N° 6 tea presented a wide colour variation (24.32), which is a value that may influence substantially the quality in terms of colour. The black and forest fruit teas showed a much lower colour difference of 8.05 and 7.11 respectively. Even with a much lower impact, these lower colour differences are still perceived by the human eye, but very close to the value of 6, usually accepted for food products. However, these values may be minimized with lower exposition to light and oxygen during processing, and shortening the processing time by using a higher membrane area.

Table 3.4 Differences in the colour of teas before and after the concentration process. Subscripts I, F and R represents Initial juice, Final juice and Reconstituted to the initial concentration juice respectively.

	$\Delta E_{I;F}^*$	$\Delta E_{I;R}^*$
<b>Medicinal Rosil N° 6 tea</b>	69.18	24.32
<b>Black tea</b>	37.42	8.05
<b>Forest fruit tea</b>	30.21	7.11

### 3.4 Intercalary Remarks

During the concentration process, there was a decrease in the driving force due to the dilution of the osmotic solution, which consequently led to a reduction in the water flux, while the overall mass transfer coefficient remained constant. In what concerns to the beverages concentration, medicinal Rosil N° 6 tea was concentrated four times while black and forest fruit teas concentrated three times.

A decrease of antioxidant activity and total phenols for two of the concentrated teas (medicinal Rosil N° 6 and black) was observed, more pronounced after 6 hours of operation.

The medicinal Rosil N° 6 and lack teas showed significant and positive correlations between antioxidant activity and phenolic content, however this positive correlation was not obtained for the forest fruit tea.

The colour differences between concentrated tea reconstituted to the initial concentration and the colour of the tea before the concentration process, may be detected by the consumers, especially for the medicinal Rosil N° 6 tea.

### 3.5 References

- Alves, V. D., & Coelho, I. M. (2004). Effect of membrane characteristics on mass and heat transfer in the osmotic evaporation process. *Journal of Membrane Science*, 228, 159-167.
- Alves, V. D., & Coelho, I. M. (2007). Study of mass and heat transfer in the osmotic evaporation process using hollow fibre membrane contactors. *Journal of Membrane Science*, 289, 249-257.
- Benzie, I. F., & Strain, J. J. (1996). The Ferric Reducing Ability of Plasma (FRAP) as a Measure of "Antioxidant Power": The FRAP Assay. *Analytical Biochemistry*, 239, 70-76.
- Brand-Williams, W., Cuvelier, M. E., & Berset, C. (1995). Use of Free Radical Method to evaluate Antioxidant Activity. *Lebensmittel-Wissenschaft & Technologie*, 28, 25-30.
- Bui, A. V., Nguyen, H. M., & Joachim, M. (2005). Characterisation of the polarisations in osmotic distillation of glucose solutions in hollow fibre module. *Journal of Food Engineering*, 68, 391-402.
- Cassano, A., Drioli, E., Galaverna, G., Marchelli, R., Silvestro, G. D., & Cagnasso, P. (2003). Clarification and concentration of citrus and carrot juices by integrated membrane processes. *Journal of Food Engineering*, 57, 153-163.
- Cassano, A., Conidi, C., & Drioli, E. (2010). Physico-chemical parameters of cactus pear (*Opuntia ficus-indica*) juice clarified by microfiltration and ultrafiltration processes. *Desalination*, 250, 1101-1104.
- Frei, B., & Higdon, J. V. (2003). Antioxidant Activity of Tea Polyphenols In Vivo: Evidence from Animal Studies. *The Journal of Nutrition*, 133, 3275S-3284S.
- Gabelman, A., & Hwang, S. (1999). Hollow fiber membrane contactors. *Journal of Membrane Science*, 159, 61-106.
- Gliszczynska-Swiglo, A. (2006). Antioxidant activity of water soluble vitamins in the TEAC (trolox equivalent antioxidant capacity) and the FRAP (ferric reducing antioxidant power) assays. *Food Chemistry*, 96, 131-136.
- Gostoli, C. (1999). Thermal effects in osmotic distillation. *Journal of Membrane Science*, 163, 75-91.
- Gülçin, I. (2012). Antioxidant activity of food constituents: an overview. *Archives of Toxicology*, 86, 345-391.
- Kähkönen, M. P., Hopia, A. I., & Heinonen, M. (2001). Berry Phenolics and Their Antioxidant Activity. *Journal of Agricultural and Food Chemistry*, 49, 4076-4082.
- Kähkönen, M. P., Hopia, A. I., Vuorela, H. J., Rauha, J., Pihlaja, K., Kujala, T. S., & Heinonen, M. (1999). Antioxidant Activity of Plant Extracts Containing Phenolic Compounds. *Journal of Agricultural and Food Chemistry*, 47, 3954-3962.
- Lima, J. D., Mazzafera, P., Moraes, W. S., & Silva, R. B. (2009). Tea: aspects related to the quality and prospects. *Ciência Rural*, 39, 1270-1278.
- Luís, A., Domingues, F., Gil, C., & Duarte, A. P. (2009). Antioxidant activity of extracts of Portuguese shrubs: *Pterospartm tridentatum*, *Cytisus scoparius* and *Erica spp.* *Journal of Medicinal Plants Research*, 3, 886-893.
- Merzlyak, M. N., Chivkunova, O. B., Solovchenko, A. E., & Naqvi, K. R. (2008). Light absorption by anthocyanins in juvenile, stressed, and senescing leaves. *Journal of Experimental Botany*, 59, 3903-3911.

Morais, S. M., Cavalcanti, E. S. B., Costa, S. M. O., & Aguiar, L. A. (2009). Ação antioxidante de chás e condimentos de grande consumo no Brasil. *Brazilian Journal of Pharmacognosy*, 19, 315-320.

Onsekizoglu, P., Bahceci, K. S., & Acar, M. J. (2010). Clarification and the concentration of apple juice using membrane processes: A comparative quality assessment. *Journal of Membrane Science*, 352, 160-165.

Ozgen, M., Reese, R. N., Tulio JR., A. Z., Scheerens, J. C., & Miller, A. R. (2006). Modified 2,2-Azino-bis-3-ethylbenzothiazoline-6-sulfonic Acid (ABTS) method to Measure Antioxidant Capacity of Selected Small Fruits and Comparison to Ferric Reducing Antioxidant Power (FRAP) and 2,2'-Diphenyl-1-picrylhydrazyl (DPPH) Methods. *Journal of Agricultural and Food Chemistry*, 54, 1151-1157.

Pekal, A., Drózd, P., Biesaga, M., & Pyrzyńska, K. (2011). Evaluation of the antioxidant properties of fruit and flavoured black teas. *European Journal of Nutrition*, 50, 681-688.

Ramalho, V. C., & Jorge, N. (2006). Antioxidantes utilizados em óleos, gorduras e alimentos gordurosos. *Química Nova*, 29, 755-760.

Ruan, J., Wu, X., & Hårdter, R. (1999). Effects of potassium and magnesium nutrition on the quality components of different types of tea. *Journal of the Science of Food and Agriculture*, 79, 47-52.

Sies, H. (1997). Oxidative stress: Oxidants and antioxidants. *Experimental physiology*, 82, 291-25.

Soares, S. E. (2002). Ácidos fenólicos como antioxidantes. *Revista de Nutrição*, 15, 71-81.

Sun, J., Chu, Y., Wu, X., & Liu, R. H. (2002). Antioxidant and Antiproliferative Activities of Common Fruits. *Journal of Agricultural and Food Chemistry*, 50, 7449-7454.

Swain, T., & Hillis, W. E. (1959). The phenolic constituents of *Prunus domestica*. I.—The quantitative analysis of phenolic constituents. *Journal of the Science of Food and Agriculture*, 10, 63-68.

Torun, M., Rácz, G., Fogarassy, E., Vatai, G., Dinçer, C., Topuz, A., & Özdemir, F. (2014). Concentration of sage (*Salvia fruticosa* Miller) extract by using integrated membrane process. *Separation and Purification Technology*, 132, 244-251.

Turkmen, N., Sari, F., & Velioglu, Y. S. (2006). Effects of extraction solvents on concentration and antioxidant activity of black and black mate tea polyphenols determined by ferrous tartrate and Folin-Ciocalteu methods. *Food Chemistry*, 99, 835-841.

Vasconcelos, S. M. L., Goulart, M. O. F., Moura, J. D. F., Manfredini, V., Benfato, M. S. D., & Kubota, L. T. (2007). Espécies reativas de oxigênio e de nitrogênio, antioxidantes e marcadores de dano oxidativo em sangue humano: Principais métodos analíticos para sua determinação. *Química Nova*, 30, 1323-1338.

X-RITE. (2007). *A guide to understanding colour communication*. X-Rite Form. L 10-001. P/N918-801. X-Rite Inc, Michigan, USA.

Xu, Y., Chen, S., Yuan, H., Tang, P., & Yin, J. (2012). Analysis of cream formation in green tea concentrates with different solid concentrations. *Journal of Food Science and Technology*, 49, 362-367.



## Chapter 4

---

# Study of Orange juice Concentration Process



## 4.1 Introduction

Fruit juices are beverages of high nutritional value since they are enriched with minerals, vitamins and other beneficial components for human health that are generally indicated as antioxidants (Cassano, et al., 2003). The interest of orange juice as a beverage appeared in the 20's and in 1945 concentrated fruit juices were first sold in the US market (Álvarez, et al., 2000).

Since then, the industry of fruit juices did not witness major innovations, and for that reason, nowadays fruit juices present on the market are sold in the following ways:

- Fresh juices obtained by simple squeezing and then submitted to a mild pasteurization;
- Reconstituted from concentrate.

Regarding the mapping of orange juice consumption is important to mention that the consumption of fruit juices represents about 5.3% of world consumption beverages being considered in this statistical refrigerants, nectars and juices (fresh and concentrates).

However, despite the low percentage of fruit juices consumption, it is well known that the global consumer is becoming more aware of the price, but also follow health trends. For that reason, within the segments of fruit juice, the orange flavour has a participation of 32%, standing out as the most appreciated flavour by the consumers.

Since 2003 there has been an increase over the volume consumed of fruit beverages, being 80% of the growth in this sector is representative of nectars and refreshments, the concentrated beverages also show an increase, however, less intense, with a growth of 2% per year (Neves, et al., 2010).

From a business point of view, the production of fruit juices in the form of concentrates is very advantageous, allowing the selling of seasonal products throughout the year and reducing costs associated with transportation, storage and packaging, increasing, in addition, the lifetime of the product (Álvarez, et al., 2000; Alves & Coelho, 2006; Onsekizoglu, Bahceci, & Acar, 2010)

Still, the industry of concentration of beverages implemented since the 40s is based on an evaporative concentration, which has obvious drawbacks. The first is the heat induced deterioration of sensory (colour, taste, aroma) and nutritional value (vitamins, etc.) of the finished product (concentrate). It is well known that, in the first few minutes of evaporative concentration, most of the aroma compounds contained in the raw juice are lost and the aroma profile undergoes an irreversible change (Barbe, Bartley, Jacobs, & Johnson, 1998; Petrotos & Lazarides, 2001; Nii, Jebson, & Cussler, 2002; Cassano, et al., 2003). An additional drawback in the use of vacuum evaporation is the high energy demand, despite the use of energy saving systems.

An alternative to the implemented traditional processes are, once again, the membrane processes, namely the osmotic evaporation process, which allows obtaining concentrates similar to currently marketed levels, ensuring the quality of the beverage, not being observed the thermal or chemical damages present on evaporative concentration (Cassano, Conidi, & Drioli, 2010; Onsekizoglu, Bahceci, & Acar, 2010).

The oranges used for this work were produced in Portugal and belonging to the lane-late variety. This variety is known for its sweet and soft flavour and low acid content.

Oranges are fruits with high water percentage, about 80%, and rich in vitamin C, they are an excellent source of folic acid, potassium and magnesium. One of the main characteristics of orange juice is its high content of the flavanones, hesperidin and narirutin. The compounds have shown potential beneficial properties against several diseases, as they have shown biological activity (Gliszczynska-Swiglo, 2006).

Several authors have studied the osmotic evaporation technology for juice concentration. Barbe, Bartley, Jacobs, & Johnson, (1998) tested hydrophobic membranes to assess the retention of volatile compounds during the process of osmotic evaporation, concluding that there is a relation between the retention of volatiles compounds and the pore size.

Some fruit juices, especially from citrus, present in their constitution essential oils, which act as surfactants, reducing the surface tension of the juice, ultimately leading to the entry of juice into the pores, allowing the mixture of the solutions, making the process impractical. In this context Mansouri & Fane, (1999) developed hydrophilic modified membranes with the ability to tolerate edible oils, thereby improving the membranes to dietary practices.

Vaillant, et al. (2001) assessed the potential of osmotic evaporation to concentrate clarified passion fruit juice on an industrial scale, with special attention on the final quality of the product. It was concluded in this study that the water flux is affected by the tangential velocity, temperature and concentration of the solutions. It was also noted also that the decrease in flux in an early phase is related to the dilution of the osmotic solution, and when the juice has a concentration above 40 °Bx, the water flux reduction is related mainly to the increased viscosity of the juice. Also in this context, Vaillant, et al. and other authors as Courel, Tronel-Peyroz, Rios, Dornier, & Reynes (2001) observed loss of aromas in concentrated juices.

Authors like Cassano, et al. (2003) confirmed the results obtained previously by Vaillant and Courel regarding the loss of aromas in concentration trials of kiwi and orange juice.

In 2003 Ali et al. studied the adsorption of volatile compounds in the membrane and understood that this phenomenon occurs mainly at the beginning of the concentration process. Also, agrees that factors such as the decrease of temperature and circulation velocity of juice may influence the decreasing of the aromas' transfer (Jiao, Cassano, & Drioli, 2004).

Cisse, Vaillant, Perez, Dornier, & Reynes, (2005) managed to reduce the loss of aromas by saturating the installation before starting the actual test concentration. The main reason for the loss of aromas is associated with the material that constitute the membrane since it has pronounced affinity for the aromas.

Alves & Coelho, (2006) compared the processes of osmotic evaporation and membrane distillation for the concentration of orange juice concluding that there is a higher flux as well as aromas' retention in the osmotic evaporation process.

Galaverna, et al. (2008) began the study of integrated processes for concentration of beverages. In this article, the authors concentrated orange juice through an integrated process, completing steps of

ultrafiltration, reverse osmosis and osmotic evaporation. After this study, other studies were published, such as Cassano, Conidi, & Drioli, (2010) in which the concentration technology by an integrated process was presented as a viable alternative to the current concentration process.

Onsekizoglu, Bahceci, & Acar, (2010) reported the importance of operating at low temperatures and for short periods of time to reduce the loss of aromas.

Chapter 4 is dedicated to the study of the osmotic evaporation process as a potential technology to the concentration of orange juice. The effect of the concentration process on the phenolic and ascorbic acid content, on the antioxidant activity, as well as on the colour of the juice was evaluated.

## 4.2 Experimental

### 4.2.1 Preparation of the orange juice

Oranges (lane-late variety) were purchased on a local supermarket. The juice was extracted by squeezing the fruit. Afterwards the pulp was separated by filtration with filter paper or by centrifugation at 10000 rpm for 15 minutes. The concentration of the raw juice was 12.0 - 12.6 g TSS/100g.

### 4.2.2 Concentration process by OE

Orange juice was submitted to OE experiments using a laboratory setup (figure 2.3). Two hollow fibre modules were tested (table 4.1) (annex I). The first used was the hollow fibre membrane contactor (1.7 x 55 MiniModule) with an effective surface area of 0.54 m<sup>2</sup>. This membrane contactor contains 7400 polypropylene fibres (Celgard X50-215 Microporous Hollow Fibre Membrane) with a nominal pore size of 0.04 µm, 40% porosity, 18 cm long, an internal diameter of 220 µm and a thickness of 40 µm. The second hollow fibre membrane contactor used (2.5 x 8 EXTRA-FLOW Liqui-Cel) had an effective surface area of 1.4 m<sup>2</sup>. This membrane contactor contains 10200 polypropylene fibres (Celgard X50-215 Microporous Hollow Fibre Membrane) with a nominal pore size of 0.04 µm, 40% porosity, 25.64 cm long, an internal diameter of 220 µm and a thickness of 40 µm.

Table 4.1 Characteristics table of the two membrane contactors used in the concentration process of fresh Orange juice.

Characteristics	1.7 x 55 MiniModule	2.5 x 8 EXTRA-FLOW Liqui-Cel
Surface area	0.54 m <sup>2</sup>	1.4 m <sup>2</sup>
Fibres number	7400	10200
Fibres type	X50 – Celgard	X50 – Celgard
Pore size	0.04 µm	0.04 µm
Porosity	40%	40%
Long	18 cm	25.64 cm
Internal diameter	220 µm	220 µm
Thickness	40 µm	40 µm

The orange juice was recirculated in the shell side of the membrane module and the calcium chloride anhydrous solution 5 M (Panreac, Spain) recirculated in the lumen of the fibres in a counter-current mode. The laboratory setup was operated as described in experimental section of chapter 3.

The initial volume of the osmotic solution was 8000 ml in each experimental run. Calcium chloride was not added to the osmotic solution during the process. Inlet and outlet pressures of both tube side and shell side were monitored ( $P_{shell_{in}} = 0.15$  bar;  $P_{shell_{out}} = 0$  bar;  $P_{fibres_{in}} = 0.3$  bar;  $P_{fibres_{out}} = 0$  bar) as well as the inlet temperature ( $25\text{ }^{\circ}\text{C} \pm 1\text{ }^{\circ}\text{C}$ ). The temperature profiles during the concentration process are described in annex III. ( $Re_{fibres} = 0.9$  and  $Re_{shell} = 2.6$ ).

In order to evaluate the water flux, the weight loss of the juice vessel, with an initial orange juice volume of 2000 ml, was measured over time with a balance (Kern, Germany).

#### 4.2.3 Total phenolic and ascorbic acid content

The total phenolic content was determined using the Folin-Ciocalteu method as described in in experimental section of chapter 3. The phenolic content was measured after rediluting the concentrated juice to the same concentration of the initial orange juice sample, and the results are expressed in mg GAE/ml juice.

Ascorbic acid content was determined using the 2,6 – dichlorophenolindophenol – Xylene extraction method recognized by AACC International. Approved Methods of Analysis, (1999). L-ascorbic acid was used to prepare a standard solution (1mg/ml). The ascorbic acid concentration was calculated by comparison with the standard and expressed as  $\mu\text{g/g}$  juice.

All the samples were analysed in triplicate with each of the tea samples taken every two hours and the start and end of each beverage sample. The data presented are the average of triplicates. The calibration curves for the Folin-Ciocalteu method and for the determination of ascorbic acid content are present in annex IV.

#### 4.2.4 Antioxidant Activity

The antioxidant activity was determined during the concentration process using two methods, radical scavenging activity (DPPH) and ferric reducing antioxidant power (FRAP), as described in experimental section of chapter 3.

The antioxidant activity was measured after rediluting the concentrated juice to the same concentration of the initial orange juice sample. When necessary dilutions of the samples were performed. Results are expressed in mM TE/ml juice (DPPH) and g ferrous sulphate/ml juice (FRAP).

All the samples were analysed in triplicate with each of the tea samples taken every two hours and the start and end of each beverage sample. The data presented are the average of triplicates. The calibration curves for the FRAP and DPPH methods are present in annex IV.

#### 4.2.5 Viscosity measurement

Viscosity measurements were performed using a Modular Advanced Rheometer System (Mars III, Haake, Germany) with a cone and plate geometry (cone diameter 35 mm, angle  $2^\circ$ ), at a temperature of  $27^\circ\text{C}$ , for a shear rate range from 0.1 to  $1000\text{ sec}^{-1}$

Three replicates were performed and the presented values correspond to the average of total measurements.

#### 4.2.6 Colour analysis

Colour values were evaluated by CIELAB colour space (illuminant D65/10° observer) on Unicam UV/Vis spectrophotometer with Chroma Colour Measurement Software, V 2.0, Unicam (Hungary).

Two measurements were made on each of the three samples (initial juice, concentrate final juice and reconstituted juice) and the variation in percentage reflectance values over a range of 380-770 nm was recorded. After these measurements, the colour differences ( $\Delta E$ ) were calculated.

### 4.3 Results and Discussion

#### 4.3.1 Evaluation of the concentration process by OE

The concentration of orange juice by OE was studied in two different modules. In a first phase, the module used was the same as used in concentrations trials of teas (1.7 x 55 MiniModule). The water flux obtained over time is presented in figure 4.1.

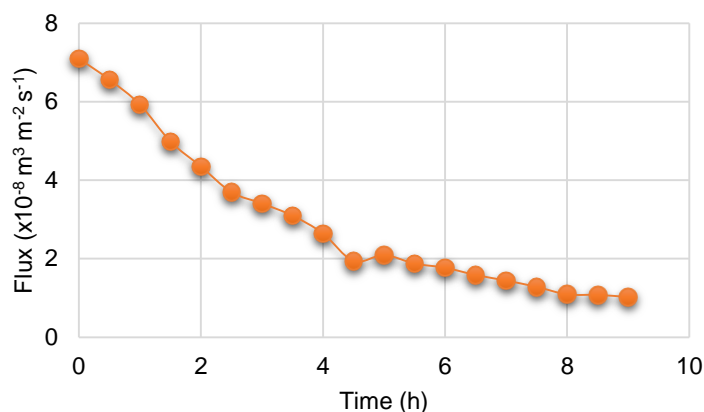

Figure 4.1 Water flux as a function of the time performed with 1.7 x 55 MiniModule.

It can be observed a substantial decrease of the water flux over time. This decrease was attributed to two main factors. Firstly, the orange juice used in this experiment was filtrated with a filter paper which originated only a partially clarified juice. For this reason, the small particles of pulp still present in the juice tended to accumulate in the shell between the fibres, which increased substantially the mass transfer resistance in the shell side with negative consequences on the flux. On the other hand, given the configuration of the membrane contactor, the juice distribution through the shell could be limited with the creation of stagnant zones or preferred pathways of fluid flow (Onsekizoglu, Bahceci, & Acar, 2010).

Due to the reasons pointed above, a second experiment was carried out with a new membrane contactor, 2.5 x 8 EXTRA-FLOW Liqui-Cel. This module as indicated in table 4.1 has an area three times higher than the previous one, and the fibres that constitute the module are equal to the previously used. For this motive, it was possible to operate the process at very similar hydrodynamic conditions in the fibres as in the module previously tested. In addition, in the 2.5 x 8 EXTRA-FLOW Liqui-Cel module the shell are arranged with fluid distributors, in order to enhance the hydrodynamic conditions.

The juice concentration over time is presented in figure 4.2. The concentration of the orange juice at a first period increased slowly, but after it achieved the 20 °Bx the increase began to be much faster, quickly achieving the concentration of 50 °Bx. This results were already expected taking into account the literature references (Cassano, et al., 2003; Cassano, Conidi, & Drioli, 2010; Onsekizoglu, Bahceci, & Acar, 2010).

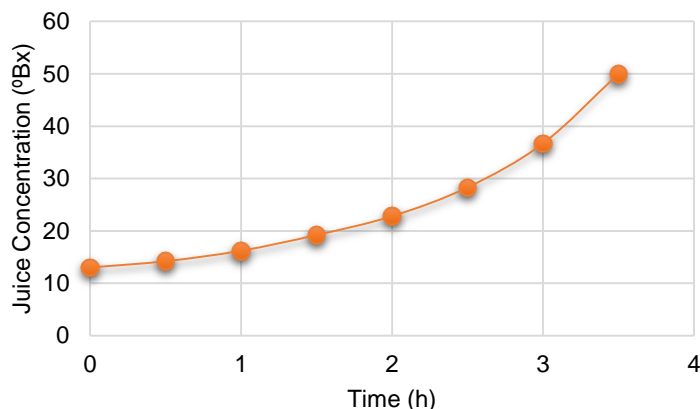

Figure 4.2 Concentration of Orange Juice as a function of the time using the 2.5 x 8 EXTRA-FLOW Liqui-Cel module.

The concentration of the fresh orange juice could have been even more pronounced if it had been used a larger volume of fresh orange juice, but due to the dead volume that it is accumulated inside the shell was only possible to reach 50 °Bx. Even so, it was possible to concentrate the orange juice about four times in only three hours, one third of the time required with 1.7 x 55 MiniModule. This improvement happened because membrane contactor 2.5 x 8 EXTRA-FLOW Liqui-Cel has an area three times higher and better hydrodynamic conditions in the shell side of the module.

The water flux obtained over time is presented in figure 4.3. During the concentration process, a flux increase is observed in the beginning, which is due to a temperature increase of both juice and osmotic solution, until reaching a stationary state. After that, the flux remained constant and decreased substantially in the end when the orange juice achieved a concentration of about 40 °Bx. This decrease happens because of the progressive reduction of the driving force, which occurs due to the water activity increase in the osmotic solution and to its decrease in the juice (figure 4.4). These results are very similar to other studies reported by different authors (Cassano, et al., 2003; Alves & Coelho, 2006; Alves & Coelho, 2007)

In what concerns to the overall mass transfer coefficient, it remains almost constant throughout the experimental time, confirming that the changes in the flux are mainly due to the variation on the driving force and not to the increase of the mass transfer resistance in the shell side (figure 4.5). Regarding the value of the overall mass transfer coefficient, it is clear the difference between it and the one obtained with the MiniModule used in the chapter 2 and on the teas concentration processes. This variation should be based on the different hydrodynamic conditions obtained with the two different modules, however, to discuss this point correctly it is required a more detailed study of the shell side distribution of the 2.5 x 8 EXTRA-FLOW Liqui-Cel module. Also related to the overall mass transfer coefficient, after the third hour of the concentration process, when the concentration of 40 °Bx was achieved, it was observed a slight decrease on its value, also referred in literature (Cassano, et al., 2003; Alves, Koroknai, Bélafi-Bakó, & Coelho, 2004; Alves & Coelho, 2006). This situation may have happened because of the increase on the fluid viscosity (annex V), which is 0.72 Pa.s (in the worst case scenario).

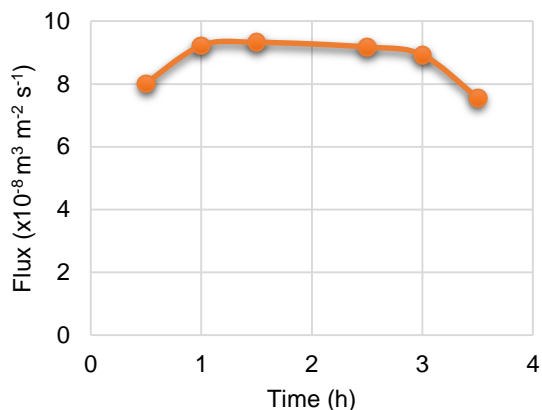

Figure 4.3 Water flux as a function of the time using the 2.5 x 8 EXTRA-FLOW Liqui-Cel module.

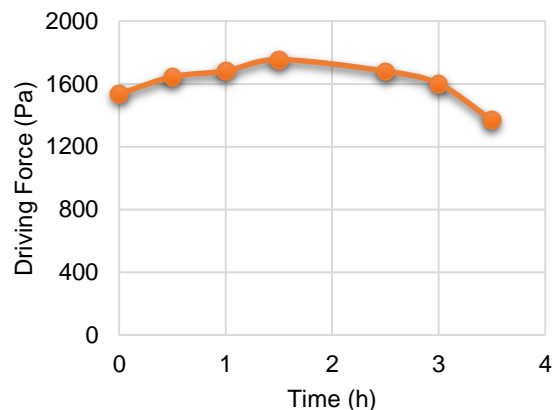

Figure 4.4 Driving force as a function of the time using the 2.5 x 8 EXTRA-FLOW Liqui-Cel module.

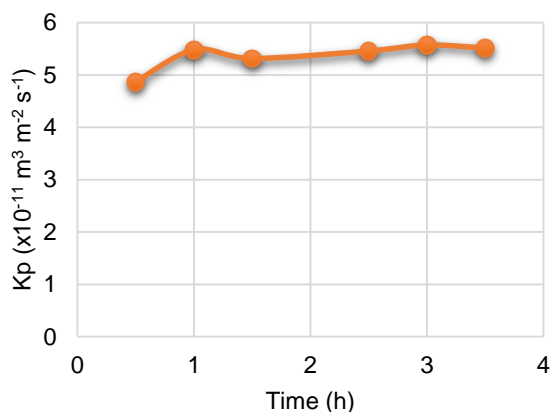

Figure 4.5 Overall mass transfer coefficient as a function of the time using the 2.5 x 8 EXTRA-FLOW Liqui-Cel module.

The results are much more interesting when compared with the results presented in figure 4.1. There are two main reasons for these results. An initial step of orange juice clarification by centrifugation, enabling the removal of the entire pulp, thus improving the hydrodynamic conditions of the process (Álvarez, et al., 2000; Cassano, Conidi, & Drioli, 2010). Another feature that allowed the improvement of the performance was the used membrane contactor. The 2.5 x 8 EXTRA-FLOW Liqui-Ce has a very different shell side distribution compared to the module 1.7 x 55 MiniModule, which has showed to have a positive influence on the concentration process by OE. Extra-Flow module contains a central shell side baffle, a feature that offers two advantages. First, the baffle improves efficiency by minimizing shell side bypassing; second, it provides a component of velocity normal to the membrane surface, which results in a higher mass transfer coefficient than that achieved with strictly parallel flow (Gabelman & Hwang, 1999).

### 4.3.3 Antioxidant Activity

The antioxidant activity was determined during the concentration process using two methods, radical scavenging activity (DPPH) and ferric reducing antioxidant power (FRAP), by reacting beverages samples collected during the concentration process with the DPPH radical or FRAP reagent. In addition, the content of total phenols and ascorbic acid was evaluated.

#### 4.3.3.1 Total phenolic content

The juice phenolic content over the concentration process by OE process is shown in figure 4.6, where it is possible to verify the increase of the phenolic concentration. The initial concentration value is in agreement with previous studies (Gardner, White, McPhail, & Duthie, 2000; Sun, Chu, Wu, & Liu, 2002). However, this increase is associated with the water removal during the process. The effective mass of phenolic compounds (mg GAE) in the juice over time is presented in table 4.2. It may be observed the maintenance of the values until the second hour of the concentration process, followed by a loss of 27.26% after 3.5h.

The loss of phenolic compounds, similar to what happens to the analysed teas, was related to the time and the process conditions (exposition to light and oxygen). Still, if the process is carried out in two hours it is expected the retention of phenolic compounds from 94% to 100%, as obtained by other authors (Onsekizoglu, Bahceci, & Acar, 2010; Torun, et al., 2014).

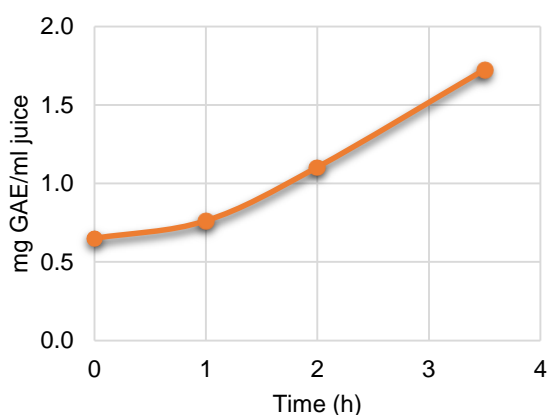

Table 4.2 Effective mass of phenolics (mg GAE) during the concentration process.

Time (h)	Phenolic content (mg GAE)
0.0	1222.1
1.0	1092.0
2.0	1091.5
3.5	776.7

Figure 4.6 Total phenolic content through the concentration process for orange juice.

#### 4.3.3.2 Ascorbic acid content

Ascorbic acid represents 65-100% of the antioxidant potential of beverages derived from citrus fruit, being the most important antioxidant of the orange juice (Gardner, White, McPhail, & Duthie, 2000). The ascorbic acid content was measured before and after the concentration process. The results were calculated according to the equation 4.1 and are present in the table 4.3.

$$\text{Ascorbic acid, } \frac{\mu\text{g}}{\text{g}} = R \times \frac{2V_t}{w}$$

Equation 4.1

Where R is the reading of concentration ( $\mu\text{g/ml}$ ) on standard curve corresponding to difference in absorbance of total dye minus absorbance of sample,  $V_t$  is the volume in ml of dilution in the extraction protocol step and  $w$  correspond to the weight in g of slurry taken in the extraction protocol step.

Table 4.3 Ascorbic acid content before and after the Orange juice concentration process by OE.

<b>Initial (fresh orange juice)</b>	<b>Final (concentrated orange juice)</b>
159.73 $\mu\text{g}$ ascorbic acid /g Orange juice	430.29 $\mu\text{g}$ ascorbic acid /g Orange juice

It was observed that the orange juice was concentrated about four times, so it would be expected an increase of the ascorbic acid concentration of four times. However, that increase is not achieved. Instead, the ascorbic acid content increases about three times. In terms of mass, the initial volume of orange juice contained 300.3 mg of ascorbic acid, and the final concentrated juice registered a content of 202.3 mg. As such, about, 67.4% of the initial ascorbic acid mass was maintained. The ascorbic acid content in the fresh juice was lower when compared with literature (Burdulu, Koca, & Karadeniz, 2006; Galaverna, et al., 2008), however such values vary with the variety of orange, as well as geographical factors. The results are positive taking into account the conditions under which the concentration experiment was performed, as well as, the fast degradation of ascorbic acid when exposed to sunlight and oxygen.

#### 4.3.3.3 Antioxidant activity

Regarding the analysis of antioxidant potential by the FRAP method it was possible to see the maintenance of the antioxidant activity throughout the entire concentration process (figure 4.7). The results obtained by the FRAP method are in agreement with the literature, since it has been reported that the osmotic evaporation does not influence the level of antioxidant activity of the orange juice (Cassano, et al., 2003; Galaverna, et al., 2008).

The results obtained by DPPH method reported a very large decrease in antioxidant activity during the first hour, corresponding to a decrease of 81.5% of the initial antioxidant potential. After the first hour, and to the end of the test the antioxidant activity remained constant (figure 4.8).

Gülçin, 2012 reported that proteins are precipitated in the alcoholic reaction medium of DPPH, as well as polysaccharides. The orange juice samples were added directly to the DPPH solution. Furthermore, the initial sample was diluted ten times more than the others. Thereby the concentration of polysaccharides in that sample was lower. The polysaccharides precipitation results in the formation of aggregates potentially entrapping the antioxidant compounds preventing their reaction with the DPPH radical. Since the polysaccharides concentration on the initial sample was lower, the reaction between antioxidant compounds and the DPPH radical was facilitated, increasing the concentration of TE. Therefore the decrease in antioxidant activity in the DPPH method may not correspond to an effective decrease in antioxidant activity but to reaction limitations.

So, the discrepancy between the results obtained by the two methods lies on differences in the reaction kinetics of phenolic standards among assays (Gülçin, 2012). It is important to refer that the potential for the generation of new antioxidant through polymerization of phenolic compounds in fruit juices may lead to the underestimation of the true antioxidant potential (Ozgen, Reese, Tulio JR., Scheerens, & Miller, 2006)

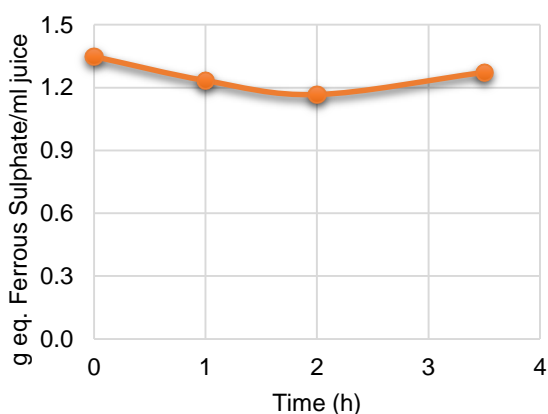

Figure 4.7 Antioxidant activity through concentration process by FRAP method for orange juice

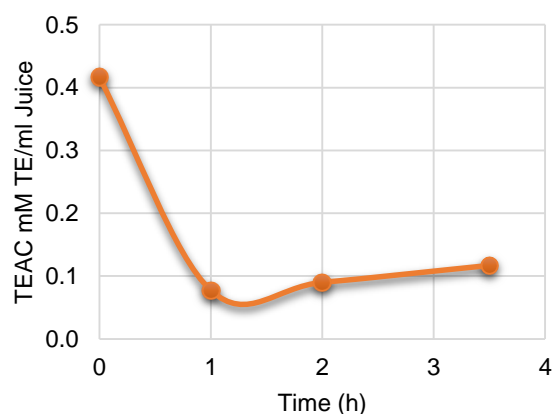

Figure 4.8 Antioxidant activity through concentration process by DPPH method for orange juice.

#### 4.3.3.4 Relation between antioxidant activity and total phenolic content

The relations obtained between the results of FRAP or DPPH methods and phenolic compounds, when analysed all samples, was not significant (figures 4.9; 4.10), suggesting the presence of other compounds with antioxidant potential than phenolics, namely ascorbic acid.

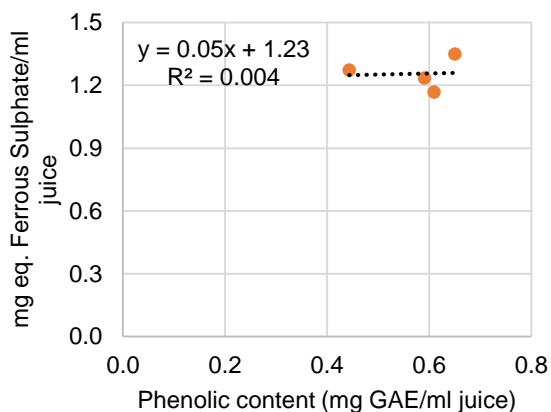

Figure 4.9 Relation between phenolic content and antioxidant activity (FRAP) for orange juice.

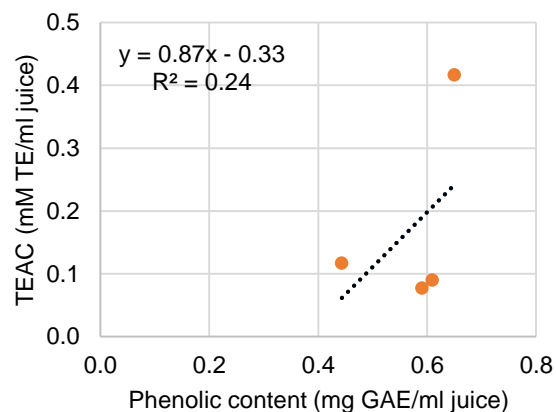

Figure 4.10 Relation between phenolic content and antioxidant activity (DPPH) for orange juice.

#### 4.3.4 Colour analysis

Table 4.4 presents the colour evaluation before and after the concentration procedure, and of the concentrated orange juice reconstituted to the original concentration.

Table 4.4 Differences in the colour of orange juice before and after the concentration process. Subscripts I, F and R represents Initial juice, Final juice and Reconstituted to the initial concentration juice respectively.

	$\Delta E_{I,F}^*$	$\Delta E_{I,R}^*$
<b>Orange juice</b>	36.58	10.37

The value of  $\Delta E_{I,R}^*$  was superior to the level accepted as a reference ( $\Delta E^* = 6$ ), but similarly to the black and forest fruit teas, it is adjustable through improved conditions of osmotic evaporation process. The main reason for this difference in colour before and after the concentration process is the eventual loss in the content of ascorbic acid that result in the formation of brown pigments (Burdulu, Koca, & Karadeniz, 2006).

To validate the possibility of browning in the final juice, the browning index (BI) as well as the whiteness index (WI) were calculated according to the follow expressions (Lunadei, Galleguillos, Diezma, & Lleó, 2011; Hsu, Chen, Weng, & Tseng, 2003):

$$BI = \frac{(x - 0.31)}{0.172} \times 100$$

Where x is the chromaticity coordinate calculated from the XYZ values, according to the following formula  $x = X/(X+Y+Z)$ .

$$WI = 100\sqrt{(100 - L)^2 + a^2 + b^2}$$

Where L defines lightness, a represents the red/green value and b is the yellow/blue value.

Table 4.5 Whiteness index and browning index for the orange juice before and after (reconstituted for the initial concentration) the concentration process.

<b>Orange juice stage</b>	<b>Whiteness index (WI)</b>	<b>Browning Index (BI)</b>
<b>Before concentration process</b>	49.64	52.12
<b>After concentration process</b>		
(reconstituted to initial concentration)	39.38	69.91

Table 4.5 confirms the generation of browning pigments in the orange juice after the concentration process, caused eventually by the ascorbic acid degradation. The concordance between the results calculated by both methods validates the result.

#### **4.4 Intercalary remarks**

In the concentration process with 1.7 x 55 MiniModule it was observed a large decrease of the water flux. With the purpose of shorten the experimental duration and improve the process of concentration the 2.5 x 8 EXTRA-FLOW Liqui-Cel was used. A slight decrease in driving force, was observed, which was caused by the decrease on the water activity of the orange juice, which consequently reduced the water flux through the membrane.

These two experiments allow to conclude that there are two main factors for the concentration of orange juice by osmotic evaporation: (i) A initial clarification stage; (ii) The utilization of a module with good hydrodynamic conditions, being this last a very important criteria for the optimization of the concentration process.

Orange juice showed that antioxidant activity and phenolic content remain constant during the concentration process. Ascorbic acid has a satisfactory performance taking into account the experimental conditions, since it is degraded just one third of the initial content.

The colour difference between concentrated juice reconstituted to the initial concentration and the colour of the orange juice before the concentration process may be detected by the consumers.

## 4.5 References

AACC International. Approved Methods of Analysis, 11<sup>th</sup> Ed. Method 86-10.01. Ascorbic Acid - Indophenol-Xylene Extraction Method. Approved November 3, 1999. AACC International, St Paul, MN, USA. <http://dx.doi.org/10.1094/AACCIntMethod-86-10.01>

Álvarez, S., Riera, F. A., Álvarez, R., Coca, J., Cuperus, F. P., Bouwer, S. T., Boswinkel, G., Gemert, R.W., Veldsink, J.W., Giorno, L., Donato, L., Todisco, S., Drioli, E., Olsson, J., Trägårdh, G., Gaeta, S.N., Panyor, L. (2000). A new integrated membrane process for producing clarified apple juice and apple juice aroma concentrate. *Journal of Food Engineering*, 46, 109-125.

Alves, V. D., Koroknai, B., Bélafi-Bakó, K., & Coelho, I. M. (2004). Using membrane contactors for fruit juice concentration. *Desalination*, 162, 263-270.

Alves, V. D., & Coelho, I. M. (2006). Orange juice concentration by osmotic evaporation and membrane distillation: A comparative study. *Journal of Food Engineering*, 74, 125-133.

Alves, V. D., & Coelho, I. M. (2007). Study of mass and heat transfer in the osmotic evaporation process using hollow fibre membrane contactors. *Journal of Membrane Science*, 289, 249-257.

Barbe, A. M., Bartley, J. P., Jacobs, A. L., & Johnson, R. A. (1998). Retention of volatile organic flavour/fragrance components in the concentration of liquid foods by osmotic distillation. *Journal of Membrane Science*, 145, 67-75.

Burdulu, H. S., Koca, N., & Karadeniz, F. (2006). Degradation of vitamin C in citrus juice concentrates during storage. *Journal of Food Engineering*, 74, 211-216.

Cassano, A., Drioli, E., Galaverna, G., Marchelli, R., Silvestro, G. D., & Cagnasso, P. (2003). Clarification and concentration of citrus and carrot juices by integrated membrane processes. *Journal of Food Engineering*, 57, 153-163.

Cassano, A., Conidi, C., & Drioli, E. (2010). Physico-chemical parameters of cactus pear (*Opuntia ficus-indica*) juice clarified by microfiltration and ultrafiltration processes. *Desalination*, 250, 1101-1104.

Cisse, M., Vaillant, F., Perez, A., Dornier, M., & Reynes, M. (2005). The quality of orange juice processed by coupling crossflow microfiltration and osmotic evaporation. *International Journal of Food Science & Technology*, 40, 105-116.

Courel, M., Dornier, M., Herry, J. M., Rios, G. M., & Reynes, M. (2000). Effect of operating conditions on water transport during the concentration of sucrose solutions by osmotic distillation. *Journal of Membrane Science*, 170, 281-289.

Gabelman, A., & Hwang, S. (1999). Hollow fiber membrane contactors. *Journal of Membrane Science*, 159, 61-106.

Galaverna, G., Silvestro, G. D., Cassano, A., Sforza, S., Dossena, A., Drioli, E., & Marchelli, R. (2008). A new integrated membrane process for the production of concentrated blood orange juice: Effect on bioactive compounds and antioxidant activity. *Food Chemistry*, 106, 1021-1030.

Gardner, P. T., White, T. A. C., McPhail, D. B., & Duthie, G. G. (2000). The relative contributions of vitamin C, carotenoids and phenolics to the antioxidant potential of fruit juices. *Food Chemistry*, 68, 471-474.

Gliszczynska-Swiglo, A. (2006). Antioxidant activity of water soluble vitamins in the TEAC (trolox equivalent antioxidant capacity) and the FRAP (ferric reducing antioxidant power) assays. *Food Chemistry*, 96, 131-136.

Gülçin, I. (2012). Antioxidant activity of food constituents: an overview. *Archives of Toxicology*, 86, 345-391.

Hsu, C. L., Chen, W., Weng, Y., & Tseng, C. Y. (2003). Chemical composition, physical properties, and antioxidant activities of yam flours as effected by different drying methods. *Food Chemistry*, 83, 85-92.

Jiao, B., Cassano, A., & Drioli, E. (2004). Recent advances on membrane processes for the concentration of fruit juices: a review. *Journal of Food Engineering*, 63, 303-324.

Lunadei, L., Galleguillos, P., Diezma, B., Lleó, L., & Ruiz-Garcia, L. (2011). A multispectral vision system to evaluate enzymatic browning in fresh-cut apple slices. *Postharvest Biology and Technology*, 60, 225-234.

Mansouri, J., & Fane, A. G. (1999). Osmotic distillation of oily feeds. *Journal of Membrane Science*, 153, 103-120.

Neves, M. F., Trombin, V. G., Milan, P., Lopes, F. F., Cressoni, F., & Kalaki, R. (2010). *O retrato da citricultura brasileira*. Brasil: Markestrat.

Nii, S., Jebson, R. S., & Cussler, E. L. (2002). Membrane evaporators. *Journal of Membrane Science*, 201, 149-159.

Onsekizoglu, P., Bahceci, K. S., & Acar, M. J. (2010). Clarification and the concentration of apple juice using membrane processes: A comparative quality assessment. *Journal of Membrane Science*, 352, 160-165.

Ozgen, M., Reese, R. N., Tulio JR., A. Z., Scheerens, J. C., & Miller, A. R. (2006). Modified 2,2-Azino-bis-3-ethylbenzothiazoline-6-sulfonic Acid (ABTS) method to Measure Antioxidant Capacity of Selected Small Fruits and Comparison to Ferric Reducing Antioxidant Power (FRAP) and 2,2'-Diphenyl-1-picrylhydrazyl (DPPH) Methods. *Journal of Agricultural and Food Chemistry*, 54, 1151-1157.

Petrotos, K. B., & Lazarides, H. N. (2001). Osmotic concentration of liquid foods. *Journal of Food Engineering*, 49, 201-206.

Sun, J., Chu, Y., Wu, X., & Liu, R. H. (2002). Antioxidant and Antiproliferative Activities of Common Fruits. *Journal of Agricultural and Food Chemistry*, 50, 7449-7454.

Torun, M., Rácz, G., Fogarassy, E., Vatai, G., Dinçer, C., Topuz, A., & Özdemir, F. (2014). Concentration of sage (*Salvia fruticosa* Miller) extract by using integrated membrane process. *Separation and Purification Technology*, 132, 244-251.

Vaillant, F., Jeanton, E., Dornier, M., O'Brien, G. M., Reynes, M., & Decloux, M. (2001). Concentration of passion fruit juice on an industrial pilot scale using evaporation. *Journal of Food Engineering*, 47, 195-202.



## Chapter 5

---

# Conclusions and Future Perspectives



## 5.1 General Conclusions

Osmotic evaporation was proposed as an alternative process for the concentration of beverages at room temperature with the intention of obtaining concentrates with organoleptic and nutritional properties superior to those of commercial products produced by evaporation.

The experimental study included the following phases: (i) optimization of the hydrodynamic conditions of the process; (ii) Concentration of beverages (teas and orange juice); (iii) Evaluation of the antioxidant activity, colour and bioactive components of the beverages.

The influence of concentration varies in the case of osmotic solution or sucrose solution. Higher concentrations of osmotic agent promote higher water fluxes since the water activity decreases, thereby increasing the driving force associated with the process. On the other hand, the higher sucrose concentration in the solution leads to increased viscosity of the solution thereby reducing the water flux. With regard to the flow rate of the solutions, it was found that higher flow velocities in the fibres correspond to higher permeate flux, but this relation was not as significant in the shell side.

The mass transfer correlations obtained for both tube and shell sides are respectively  $Sh=0.6Re^{1.01} Sc^{0.33} (d/L)^{0.33}$  and  $Sh=0.7(Re_{h/L})^{0.93} Sc^{0.33}$ .

During the concentration process of teas, there was a decrease in the driving force due to the dilution of the osmotic solution, which consequently led to a reduction in the water flux, while the overall mass transfer coefficient remained constant. Medicinal Rosil N° 6 tea was concentrated four times while black and forest fruit teas concentrated three times.

In the concentration process of orange juice with 1.7 x 55 MiniModule it was recorded a large decrease of the water flux. However with the 2.5 x 8 EXTRA-FLOW Liqui-Cel the flux was general maintained constant during the entire experimental time and the juice was concentrated from 11°Bx to 50°Bx. These two experiments allow to conclude that there are two main factors for the concentration of orange juice by osmotic evaporation: (i) An initial clarification stage; (ii) The utilization of a module with good hydrodynamic conditions, being this last a very important criteria for the optimization of the concentration process.

The study of the antioxidant properties of the concentrated teas showed the maintenance of antioxidant activity of the forest fruit tea throughout the concentration experiment and reduction of the antioxidant activity for the other two teas (medicinal Rosil N° 6 tea and black tea) more pronounced after the 6 hour of the experiment. It was observed a positive relation between antioxidant activity and phenolic content for medicinal Rosil tea and black tea. With respect to the colour of the reconstituted teas, some change was observed, especially for the medicinal Rosil N° 6 tea.

Antioxidant activity was maintained in the concentrated orange juice, as well as 67.3% of ascorbic acid. It was recorded alterations in the colour on the final orange juice reconstituted to the initial concentration. The main reason for the colour change was the loss of ascorbic acid responsible for the production of browning pigments.

However it should be noted that the *in vitro* evaluation of antioxidant activity, as well as, the phenolic content, represent only the bioactive potential of the analysed beverages,

The decrease in the observed quality of the beverages is mainly associated to the conditions how the osmotic evaporation process was performed. In the experimental setup used the interaction with the oxygen and light throughout the testing time was inevitable. Therefore, taking into account the experimental conditions, the results are very positive and easily improved using experimental conditions with minimum oxygen and light exposure.

Moreover, the time needed for concentration can be reduced by using a membrane contactor with a larger area.

## 5.2 Suggestions for Future Research

The osmotic evaporation process is quite promising in order to obtain the production of high quality juice concentrates with theoretical lower costs than the current applied at the industrially evaporation process.

This process has been studied over the years, particularly with regard to variables of the same. Yet this process of concentration still has aspects that deserve to be improved and on which fall the suggestions for future work.

- Improving the flux of evaporated water through the membrane. For this purpose should be studied membranes with high porosity and low thickness.
- Study the osmotic evaporation as part of an integrated process looking for the development of a more efficient process with minimal associated costs. In an initial phase of an integrated process, is possible to clarify the beverage, in a second phase should be removed most of the present water in the beverage, reverse osmosis may be used for this purpose, and subsequently a later stage using the process of evaporation.
- Develop strategies to reduce the loss of aroma compounds, either the development of membranes with lower affinity for these compounds, or development of a pervaporation process coupled to the osmotic evaporation process, allowing to obtain a product more similar to the natural beverage.
- Develop a process as similar as possible to an industrial situation in order to understand how the process behaves at a larger scale.
- Develop a re-concentration methodology for the osmotic solution, with the goal of minimize the costs associated to the process, improving this way the efficiency of OE.

With regard to the particular study of this thesis, there are also aspects that deserve further attention, which would be of interest to study in the future, namely:

- To conduct a more detailed study of the hollow fibre module used for the concentration of orange juice in order to have a more detailed knowledge of the hydrodynamics conditions of operation.
- To identify specific bioactive components, in order to understand its importance and behaviour in beverages, and relate them to the antioxidant activity.
- To evaluate with accuracy the aroma profile of the beverages before and after the concentration process, pursuing to optimizing the signal obtained, identify and quantify the aroma compounds.

- To perform sensory analysis essential to ensure that the concentrate beverage obtained by this technological method presents an equal or superior quality when compared to the existing commercial products. However, for this to be possible the process of concentration by osmotic evaporation should be performed in aseptic conditions, which was not possible in this study.

## A. Annexes

---



Annex I – Hollow fibre membrane contactors specifications

Table A.1 Specifications for 1.7 x 55 MiniModule.

<b>Membrane Characteristics</b>	
Cartridge Configuration	Parallel Flow. Lumenside Liquid Flow.
Liquid Flow Guidelines	<2500 ml/min (0.66 gpm)
Membrane Type	X50 Fiber
Membrane/Potting Material	Polypropylene/Polyurethane
Typical Membrane Surface Area	ID: 0.54 m <sup>2</sup> (5.81 ft <sup>2</sup> )
<u>Priming Volume (approximate)</u>	
Shellside	78 ml
Lumenside	53 ml
<b>Pressure Guidelines</b>	
Maximum Lumenside LIQUID	20°C, 4.1 bar (68°F, 60 psig)
Working Temperature/ Pressure	40°C, 2.1 bar (104°F, 30 psig)
<b>Housing Options and Characteristics</b>	
Material	Polycarbonate
<u>Flange Connections</u>	
Shellside (gas/vacuum)	Standard Female Luer lock <i>Supplied with two ¼ inch Hosebarb adaptors which mate to ¼ inch ID tubing</i>
Lumenside (wetted surface)	1/4 inch FNPT
<b>Seal Options</b>	
Material	Applications
EPDM ANSI/NSF 61, FDA, CFR Title 21)	All Purpose
<b>Weight</b>	
Dry	142.3 g (0.31 lbs.)
Shipping weight (max)	150.7 g (0.33 lbs.)
<b>Regulatory</b>	
Meets RoHS threshold limits. CTR Title 21 compliant. FDA compliant for wetted parts only	

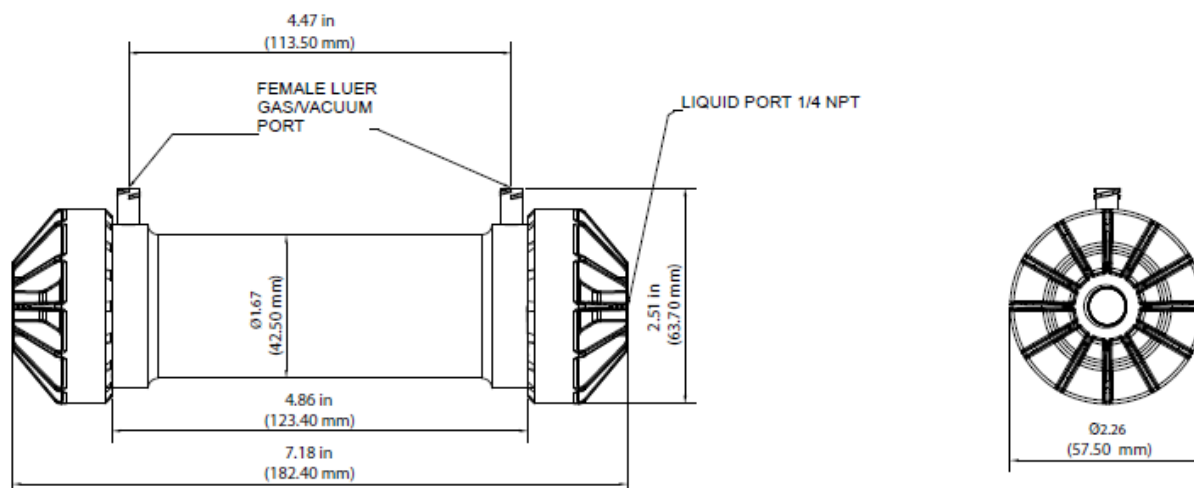

Figure A.1 Dimension specifications for the 1.7 x 55 MiniModule membrane contactor.

Table A.2 Specifications for 2.5 x 8 EXTRA-FLOW Liqui-Cel.

<b>Membrane Characteristics</b>	
Cartridge Configuration	Extra-Flow with Centre Baffle
Liquid Flow Guidelines	0.1 – 0.7 m <sup>3</sup> /hr (0.5 – 3 gpm)
Membrane Type	X50 Fibre
	Recommended for CO <sub>2</sub> removal from liquid and other gas transfer applications
	X40 Fibre
	Recommended for O <sub>2</sub> removal from liquid and other gas transfer applications
Membrane/Potting Material	Polypropylene/Polyethylene
Typical Membrane Surface Area	1.4 m <sup>2</sup> (15.1 ft <sup>2</sup> )
<u>Priming Volume (approximate)</u>	
Shellside	0.40 L (0.11 gal.)
Lumenside	0.15 L (0.04 gal.)
<b>Pressure Guidelines*</b>	
	X50 or X40 Fibre
Maximum Shellside LIQUID Working Temperature/ Pressure	5-40°C, 7.2 bar (41-104°F, 105 psig)
	70°C, 2.1 bar (158°F, 30 psig)
If no vacuum is used, 1.05 bar (15 psig) can be added to pressures above.	
Maximum Applied Gas Pressure	4.8 bar (70 psig)
Max applied gas pressure is for integrity testing at ambient temperatures. Normal operating pressures are typically lower.	
Maximum Lumenside Liquid Temperature/Pressure of Semibody Contactor	5° C, 6.2 bar (41° F, 90 psig) 15-25° C, 4.8 bar (59-77° F, 70 psig) 70° C, 1.0 bar (158° F, 15 psig)

\*Pressures are based on non-dangerous liquids and gasses per the European Union Pressure Equipment Directive /97/23/EC. See Operating Guide for pressure limits in the European Union with dangerous liquids and gasses. Also, see Operating Guide for complete temp/pressure limits for housings and membrane.  
 Note: Liquid pressure should always exceed gas pressure.

<b>Housing Options and Characteristics</b>	
Material	Polypropylene
<u>Flange Connections</u>	
Shellside (Liquid Inlet/Outlet)	¼ inch NPT female ⅜ inch Flaretek (nut included) ½ inch Flaretek (nut included)
<i>Note: Overall length with Flaretek connections increases. See website for all housing drawings</i>	
Lumenside	1/4 inch NPT female
<b>Seal Options</b>	
Material	Applications
K-UPW	Ultra Pure Water
Viton	General Purpose
K-EXT	Chemical Extraction (Clamped version only)
<b>Weight</b>	
Dry	0.5 kg. (1.1 lbs.)
Liquid full (shellside)	0.9 kg. (2 lbs.)
Shipping weight	1.2 kg. (2.4 lbs.)
<b>Regulatory</b>	
Meets RoHS threshold limits. Complies with the PED 97/23/EC and is manufactured with sound engineering practice. CFR Title 21 compliant.	

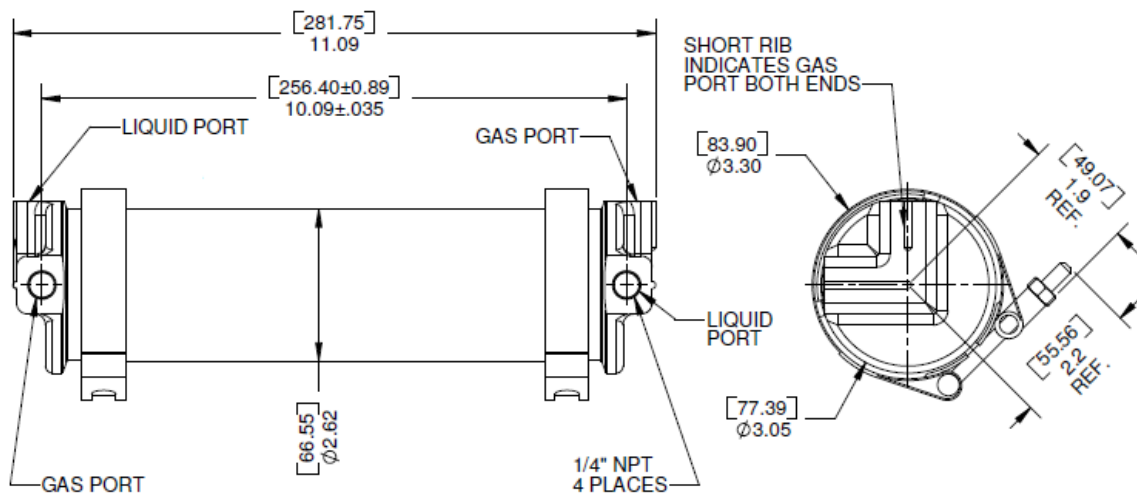

Figure A.2 Dimension specifications for the 2.5 x 8 EXTRA-FLOW Liqui-Cel membrane contactor.

Table A.3 Characteristics of Celgard, X50-215 Microporous Hollow Fiber Membrane.

<b>Product Characteristics</b>	<b>Typical Values</b>	<b>Test Method</b>
Porosity, (nominal)	40%	QT-HF-1005
Pore Dimensions	0.04 x 0.10 $\mu\text{m}$	QT-MS-1005
Effective Pore Size++	0.04 $\mu\text{m}$	QT-HF-1005
Burst Strength (min)	400 PSI (15.5 $\text{kg}/\text{cm}^2$ )	QT-HF-1008
Tensile Break Strength	$\geq 300$ grams/filament	QT-HF-1007

---

## Annex II – Calcium chloride hydrodynamic characteristics

---

This Annex corresponds to the required parameters for the hydrodynamic calculations related to calcium chloride. The parameters presented here vary with temperature, however, here are represented the base values for 25 °C.

Table A.4 Calcium chloride characteristics corresponded to 25 °C used in the hydrodynamic calculations

<b>Concentration</b> <b>M</b>	<b>Density</b> <b>Kg/m<sup>3</sup></b>	<b>Viscosity (x10<sup>-3</sup>)</b> <b>kg/(m.s)</b>	<b>D<sub>w-air</sub> (x10<sup>-9</sup>)</b> <b>m<sup>2</sup> s<sup>-1</sup></b>	<b>aw</b>
<b>1</b>	1089	1.18	2.021	0.943
<b>2</b>	1174	1.72	1.574	0.849
<b>3</b>	1255	2.49	1.187	0.713
<b>4</b>	1332	3.61	0.860	0.552
<b>5</b>	1406	5.24	0.594	0.394
<b>6</b>	1476	7.60	0.388	0.287

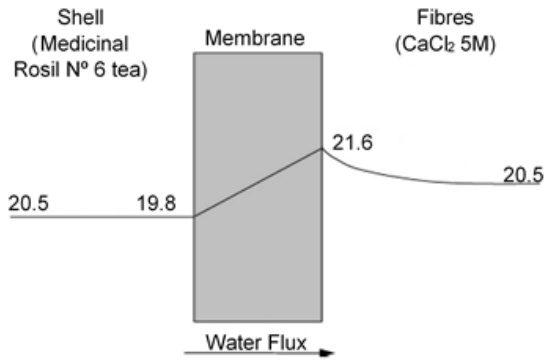

Figure A.3 Temperature profile for the Medicinal Rosil N° 6 tea concentration process. Fibres: CaCl<sub>2</sub> 5M.

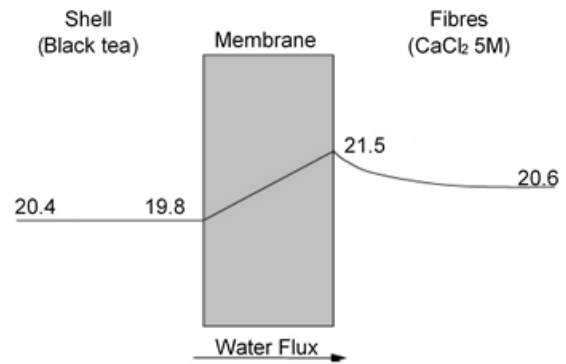

Figure A.4 Temperature profile for the Black tea concentration process. Fibres: CaCl<sub>2</sub> 5M.

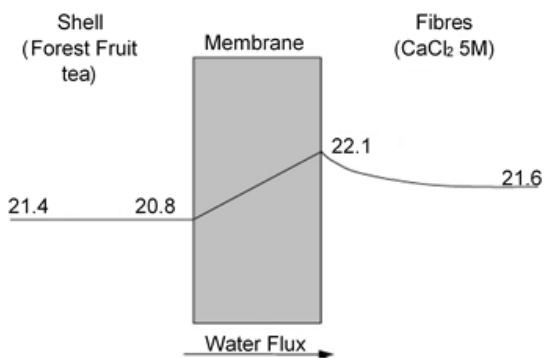

Figure A.5 Temperature profile for the Forest Fruit tea concentration process. Fibres: CaCl<sub>2</sub> 5M.

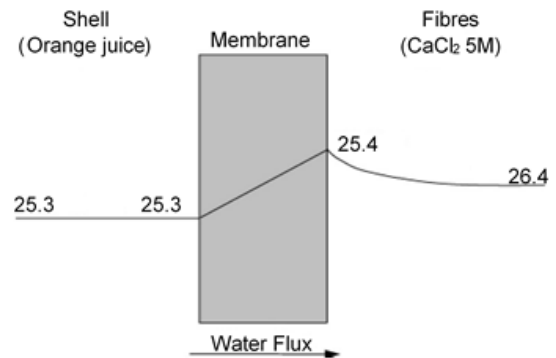

Figure A.6 Temperature profile for the Orange juice concentration process. Fibres: CaCl<sub>2</sub> 5M.

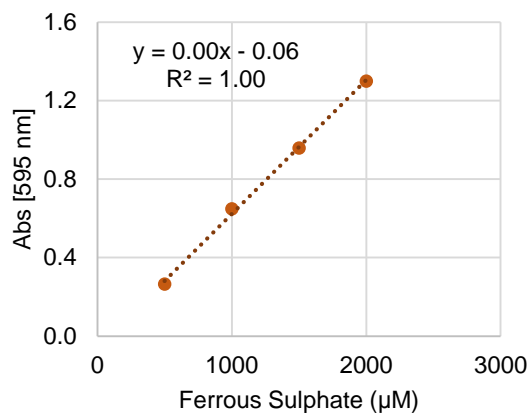

Figure A.7 Calibration curve for FRAP method.

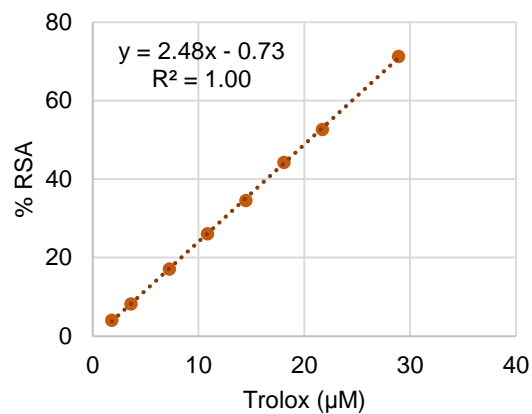

Figure A.8 Calibration curve for DPPH method.

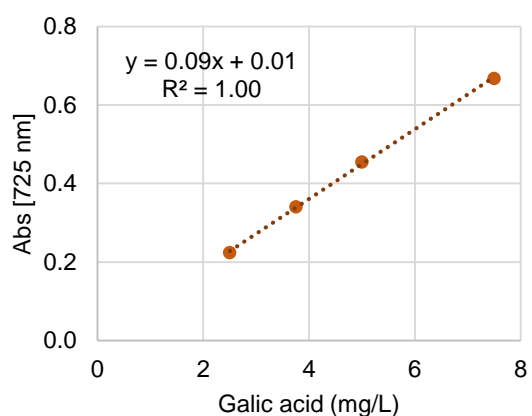

Figure A.9 Calibration curve for the Folin-Ciocalteu method.

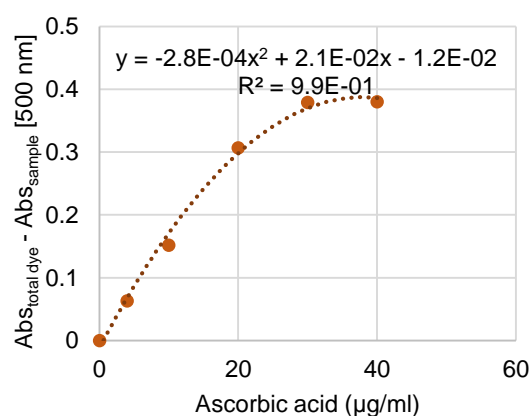

Figure A.10 Calibration curve for the 2,6 – dichlorophenolindophenol – Xylene extraction method.

The measurement of viscosity of concentrated orange juice intended to correct evaluate the overall mass transfer coefficient. Table A.1 shows the experimental conditions under which the viscosity measure was performed in the rheometer. This study concluded that although the viscosity of the orange juice was increase due to the increase of the concentration, this increasement was not enough to decrease the overall mass transfer coefficient.

Table A.5 Operating conditions for the viscosity measure of the concentrated orange juice.

Operating conditions	
Rheometer	Mars III, Haake, Germany
Geometry	Cone and plate (cone diameter 35 mm, angle 2°)
Temperature	27 °C
Shear rate	0.1 to 1000 sec <sup>-1</sup>

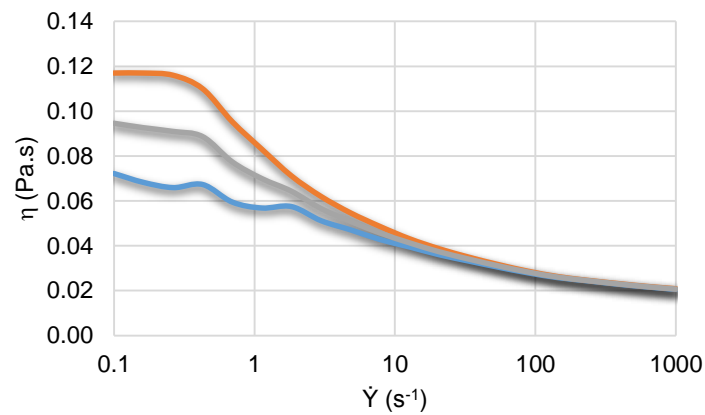

Figure A.11 Concentrated orange juice viscosity curve.