

Research Article

New discrete-time fractional derivatives based on the bilinear transformation: Definitions and properties

Manuel D. Ortigueira ^{a,*}, J.A. Tenreiro Machado ^b^a CTS–UNINOVA and NOVA Faculty of Sciences and Technology of Nova University of Lisbon, Campus da FCT da UNL, Quinta da Torre, 2829 – 516 Caparica, Portugal^b Institute of Engineering, Polytechnic of Porto, Dept. of Electrical Engineering, Porto, Portugal

HIGHLIGHTS

- The paper introduces new discrete-time derivative concepts based on the bilinear transformation.
- Forward and backward derivatives having a high degree of similarity with the usual continuous-time Grünwald-Letnikov derivatives are introduced.
- Corresponding linear discrete-time systems are defined.

GRAPHICAL ABSTRACT

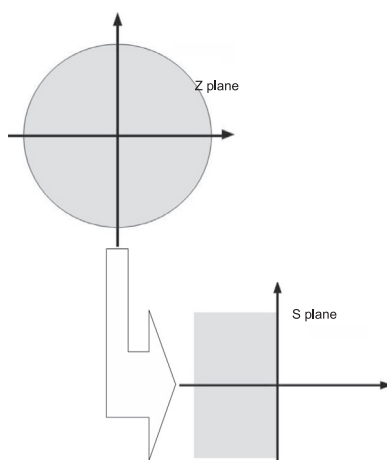

ARTICLE INFO

Article history:

Received 18 December 2019

Revised 12 February 2020

Accepted 16 February 2020

Available online 25 February 2020

Keywords:

Discrete-time

Fractional derivative

Time scale

bilinear transformation

ABSTRACT

In this paper we introduce new discrete-time derivative concepts based on the bilinear (Tustin) transformation. From the new formulation, we obtain derivatives that exhibit a high degree of similarity with the continuous-time Grünwald-Letnikov derivatives. Their properties are described highlighting one important feature, namely that such derivatives have always long memory.

© 2020 The Authors. Published by Elsevier B.V. on behalf of Cairo University. This is an open access article under the CC BY-NC-ND license (<http://creativecommons.org/licenses/by-nc-nd/4.0/>).

Peer review under responsibility of Cairo University.

* Corresponding author.

E-mail addresses: mndo@fct.unl.pt (M.D. Ortigueira), jtm@isep.ipp.pt (J.A. Tenreiro Machado).

<https://doi.org/10.1016/j.jare.2020.02.011>

2090-1232/© 2020 The Authors. Published by Elsevier B.V. on behalf of Cairo University.

This is an open access article under the CC BY-NC-ND license (<http://creativecommons.org/licenses/by-nc-nd/4.0/>).

Introduction

The continuous/discrete unification introduced by Hilger [3] led to the definition of two discrete-time fractional derivatives, nabla and delta, that are essentially the usual incremental ratios. In [11] the fractional versions of such derivatives were proposed together with the corresponding differential equations for discrete-time lin-

ear systems. These versions have stability domains that are defined by the Hilger circles [11]. Such domains do not coincide with the stability domain of traditional causal discrete-time systems that is defined relatively to the unit circle. As it is well known, the stability domain of causal continuous-time system is the right half complex plane (HCP). Therefore, there is a relation between the left (right) HCP and the interior (exterior) of the unit disk that can be expressed by a particular case the bilinear (or, Möbius) transformation. Such map was proposed by Tustin [17] and used since then for the discrete-time approximation of continuous-time linear systems without considering the definition of any discrete-time derivative [18,13,14]. Hereafter we formulate a discrete-time fractional calculus that mimics the corresponding continuous-time version, but that is fully autonomous. The motivation for this study is to have in the discrete-time domain the tools and results available for the continuous-time fractional signals and systems [10]. Another important characteristic of the proposed derivatives is that they are suitable to be implemented through the FFT with the corresponding advantages, from the numerical and calculation time perspectives.

The new derivatives

On the Z and Discrete-Time Fourier Transforms

In the following we consider that our domain is the *time scale*

$$\mathbb{T}_h = (h\mathbb{Z}) = \{\dots, -nh, \dots, -2h, -h, 0, h, 2h, \dots, nh, \dots\}$$

with $h \in \mathbb{R}^+$, that is called graininess [1,11]. In the following the symbol n will represent any generic point in \mathbb{T} . In engineering applications where discrete signals are result of sampling continuous-time signals, h is the sampling interval.

Let $x(n)$ denote any function defined on \mathbb{T} , leaving implicit the graininess, unless it is convenient to display it. The Z transform (ZT) is defined by

$$X(z) = \mathcal{Z}[x(n)] = \sum_{n=-\infty}^{\infty} x(n)z^{-n}, \quad z \in \mathbb{C}. \tag{1}$$

In some scientific domains, as Geophysics, z instead of z^{-1} is used. In some domains, the ZT is often called “generating function” or “characteristic function”. Definition (1) is the bilateral ZT that leads to the particular case of the unilateral ZT, defined by

$$X_u(z) = \sum_{n=0}^{\infty} x(n)z^{-n},$$

often adopted in the study of systems. The existence conditions of the ZT are similar to those of the bilateral Laplace transform (LT) [7,15,16]

$$Y(s) = \mathcal{L}[y(t)] = \int_{-\infty}^{\infty} y(t)e^{-st} dt, \quad s \in \mathbb{C}. \tag{2}$$

Therefore, the existence conditions can be stated as follows.

If function $x(n)$ is such that there are finite positive real numbers, r_- and r_+ , for which

$$\sum_{n=0}^{\infty} |x(n)|r_-^n < \infty$$

and

$$\sum_{n=-\infty}^{-1} |x(n)|r_+^n < \infty, \tag{3}$$

then the ZT exists and the range of values for which those series converge defines a region of convergence (ROC) that is an annulus.

We must have in mind that this condition is sufficient, but not necessary. The signals that verify (3) are the *exponential order signals* [16].

Definition 1. A discrete-time signal $x(n)$ is called an *exponential order signal* if there exist integers n_1 and n_2 , and positive real numbers a, b, A , and B , such that $Aa^{n_1} < |x(n)| < Bb^{n_2}$ for $n_1 < n < n_2$.

For these signals the ZT exists and the ROC is an annulus centred at the origin, generally delimited by two circles of radius r_- and r_+ , such that $r_- < |z| < r_+$. However, there are some cases where the annulus can become infinite:

- If the signal is right (i.e., $x(n) = 0, n < n_0 \in \mathbb{Z}$), then the ROC is the exterior of a circle centered at the origin ($r_+ = \infty$): $|z| > r_-$.
- If the signal is left (i.e., $x(n) = 0, n > n_0 \in \mathbb{Z}$), then the ROC is the interior of a circle centered at the origin ($r_- = 0$): $|z| < r_+$.
- If the signal is a pulse (i.e., non null only on a finite set), then the ROC is the whole complex plane, possibly with the exception of the origin. In the ROC, the ZT defines an analytical function.

It should be noted that the ROC is included in the definition of a given ZT. This means that we may have different signals with the same function as ZT, but different ROC.

If the ROC contains the unit circle, then by making $z = e^{i\omega}, |\omega| < \pi, i = \sqrt{-1}$, we obtain the discrete-time Fourier transform, which we will shortly call Fourier transform (FT). This means that not all signals with ZT have FT. The signals with ZT and FT are those for which the ROC is non-degenerate and contains the unit circle ($r_- < 1, r_+ > 1$). For some signals, such as sinusoids, the ROC degenerates in the unit circumference ($r_- = r_+ = 1$), and there is no ZT.

Definition 2. The inverse ZT can be obtained by the integral defined by

$$x(n) = \frac{1}{2\pi i} \oint_{\gamma} X(z)z^{n-1} dz, \tag{4}$$

where γ is a circle centred at the origin, located in the ROC of the transform, and taken in a counterclockwise direction.

In such situation the integral in (4) converges uniformly. The calculation uses the Cauchy’s theorem of complex variable functions [16].

Definition 3. For functions that have a ROC including the unit circle or for functions having a degenerate ROC, as it is the case of the periodic signals, it is preferable to work with the discrete-time Fourier transform that can be obtained from the Z transform through the transformation $z = e^{i\omega}, |\omega| < \pi$

$$X(e^{i\omega}) = \sum_{n=-\infty}^{\infty} x(nh)e^{-i\omega n} \tag{5}$$

with the inversion integral

$$x(n) = \frac{1}{2\pi} \int_{-\pi}^{\pi} X(e^{i\omega})e^{i\omega n} d\omega \tag{6}$$

meaning that a discrete-time signal can be considered as a synthesis of elementary sinusoids $X(e^{i\omega})e^{i\omega n} d\omega$.

Remark 1. In fractional applications, we have branchcut points at $z = \pm 1$. Therefore, we have to avoid them by using an integration circle in (4) having a radius, r , greater (smaller) than 1 for the causal (anti-causal) cases. We have then

$$f(n) = \frac{r^n}{2\pi} \int_{-\pi}^{\pi} X(re^{i\omega}) e^{ion} d\omega \quad (7)$$

Forward and backward derivatives based on the bilinear transformation

The Tustin transformation is usually expressed by

$$s = \frac{2}{h} \frac{1 - z^{-1}}{1 + z^{-1}}, \quad (8)$$

where h is the sampling interval, s is the derivative operator associated with the (continuous-time) Laplace transform and z^{-1} the delay operator tied with the Z transform.

Definition 4. Let $x(nh)$ be a discrete-time function, we define the order 1 *forward bilinear derivative* $Dx(nh)$ of $x(nh)$ as the solution of

$$Dx(nh) + Dx(nh - h) = \frac{2}{h} [x(nh) - x(nh - h)] \quad (9)$$

Definition 5. Similarly, we define the order 1 *backward bilinear derivative* $Dx(nh)$ of $x(nh)$ as the solution of

$$Dx(nh + h) + Dx(nh) = \frac{2}{h} [x(nh + h) - x(nh)] \quad (10)$$

Definition 6. The bilinear exponential $e_s(nh)$ is the eigenfunction of Eq. (9) or (10). If we set $x(nh) = e_s(nh)$, $y(nh) = se_s(nh)$, $s \in \mathbb{C}$, with $e_s(0) = 1$, then

$$e_s(nh) = \left(\frac{2 + hs}{2 - hs} \right)^n, \quad n \in \mathbb{Z}, s \in \mathbb{C}. \quad (11)$$

Properties of the bilinear exponential $e_s(nh)$.

- When $n \rightarrow \infty$, this exponential is
 - Increasing, if $Re(s) > 0$,
 - Decreasing, if $Re(s) < 0$,
 - Sinusoidal, if $Re(s) = 0$, with $s \neq 0$,
 - Constant equal to 1, if $s = 0$,
- It is real for real s ,
- It is positive for $s = |x| < \frac{2}{h}$, $x \in \mathbb{R}$,
- It oscillates for $s = |x| > \frac{2}{h}$, $x \in \mathbb{R}$.

Following the procedure in [11] we could use this exponential to construct a bilinear discrete-time Laplace transform. However, formula (8) suggests having $z = \frac{2+hs}{2-hs}$ that leads to the Z transform, since such transformation sets the unit circle $|z| = 1$ as the image of the imaginary axis in s , independently of which value of h is used. Therefore, the exponential has the usual properties.

- When $n \rightarrow \infty$, this exponential is
 - Increasing, if $|z| > 1$,
 - Decreasing, if $|z| < 1$,
 - Sinusoidal, if $|z| = 1$, with $z \neq 1$,
 - Constant equal to 1, if $z = 1$,
- It is real for real z ,
- It is positive for $z = x > 0$, $x \in \mathbb{R}$,
- It oscillates for $z \neq \mathbb{R}_0^+$.

In what concerns to the derivative definitions, instead of considering (9) or (11), as in [1,11] where the nabla (causal) and delta (anti-causal) derivatives were introduced, we start from the ZT formulations.

Definition 7. Let $z \in \mathbb{C}$ and $h \in \mathbb{R}^+$. Consider the discrete-time exponential function, z^n , $n \in \mathbb{Z}$. We define the forward bilinear derivative (D_f) as a discrete-time linear operator such that

$$D_f z^n = \frac{2}{h} \frac{1 - z^{-1}}{1 + z^{-1}} z^n. \quad (12)$$

The operator $H_f(z)$ defined by

$$H_f(z) = \frac{2}{h} \frac{1 - z^{-1}}{1 + z^{-1}}, \quad |z| > 1, \quad (13)$$

will be called forward transfer function (TF) of the derivative, borrowing the nomenclature used in signal processing [7,16].

Definition 8. The backward bilinear derivative (D_b) is defined as a discrete-time linear operator verifying

$$D_b z^n = \frac{2}{h} \frac{z - 1}{z + 1} z^n. \quad (14)$$

where $H_b(z)$ is the operator

$$H_b(z) = \frac{2}{h} \frac{z - 1}{z + 1}, \quad |z| < 1, \quad (15)$$

called backward transfer function of the derivative.

By the repeated application of the above operators we obtain the forward and backward derivatives for any positive integer order. However, we introduce the corresponding fractional derivatives, valid for any real order.

Definition 9. Let $\alpha \in \mathbb{R}$. The α -order forward bilinear fractional derivative is a discrete-time operator with TF

$$H_f(z) = \left(\frac{2}{h} \frac{1 - z^{-1}}{1 + z^{-1}} \right)^\alpha, \quad |z| > 1 \quad (16)$$

such that

$$D_f^\alpha z^n = \left(\frac{2}{h} \frac{1 - z^{-1}}{1 + z^{-1}} \right)^\alpha z^n, \quad |z| > 1. \quad (17)$$

Definition 10. The backward bilinear fractional derivative has TF

$$H_b(z) = \left(\frac{2}{h} \frac{z - 1}{z + 1} \right)^\alpha, \quad |z| < 1 \quad (18)$$

such that

$$D_b^\alpha z^n = \left(\frac{2}{h} \frac{z - 1}{z + 1} \right)^\alpha z^n, \quad |z| < 1. \quad (19)$$

Having defined the derivative of an exponential we are in conditions of defining the derivative of any signal having ZT.

Definition 11. From (4) and (17) we conclude that, if $x(n)$ is a function with Z transform $X(z)$, analytic in the ROC defined by $z \in \mathbb{C} : |z| > a$, $a < 1$, then

$$D_f^\alpha x(n) = \frac{1}{2\pi i} \oint_\gamma \left(\frac{2}{h} \frac{1 - z^{-1}}{1 + z^{-1}} \right)^\alpha X(z) z^{n-1} dz, \quad (20)$$

with the integration path outside the unit disk. This implies that

$$\mathcal{Z}[D_f^\alpha x(n)] = \left(\frac{2}{h} \frac{1-z^{-1}}{1+z^{-1}}\right)^\alpha X(z), \quad |z| > 1. \quad (21)$$

Definition 12. Let $x(n)$ be a function with Z transform $X(z)$, analytic in the ROC defined by $z \in \mathbb{C} : |z| < a, a > 1$. We define

$$D_b^\alpha x(n) = \frac{1}{2\pi i} \oint_\gamma \left(\frac{2}{h} \frac{z-1}{z+1}\right)^\alpha X(z) z^{n-1} dz, \quad (22)$$

with the integration path inside the unit disk and the branchcut line is a segment joining the points $z = \pm 1$. This implies that

$$\mathcal{Z}[D_b^\alpha x(n)] = \left(\frac{2}{h} \frac{z-1}{z+1}\right)^\alpha X(z), \quad |z| < 1. \quad (23)$$

Remark 2. We must note that:

1. In (16) and (17) we have two branchcut points at $z = \pm 1$. The corresponding branchcut line is any line connecting these values and being located in the unit disk. The simplest is a straight line segment (see Fig. 1).
2. In (18) and (19) we have the same branchcut points, but with branchcut line(s) lying outside the unit disk. For simplifying, we can use two half-straight lines starting at $z = \pm 1$ on the real negative and positive half lines, respectively (see Fig. 1).
3. In both previous cases, we can extend the domain of validity to include the unit circumference, $z = e^{i\omega n}, |\omega| \in (0, \pi)$, with exception of the points $z = \pm 1$. In these cases the integration path in (4) must be deformed around such points, as it can be seen at Fig. 2 for the causal case. This deformation is very important in applications where we use the fast Fourier transform (FFT). In such cases a small numerical trick can be used: push the branchcut points slightly inside (outside) the unit circle, that is, to $z = -1 + \varepsilon$ and $z = 1 - \varepsilon(-1 - \varepsilon, 1 + \varepsilon)$, with ε being a small positive real number.
4. The ROC is independent on the scale graininess, h , and consequently we can establish a one to one correspondence between the unit disk, in z , and the left half-plane, in $s = \frac{2}{h} \frac{1-z^{-1}}{1+z^{-1}}$.

Example 1. In Figs. 3 and 4 we represent the bilinear causal derivatives of orders $\alpha = 0.5$ and $\alpha = 0.8$ of a triangle function.

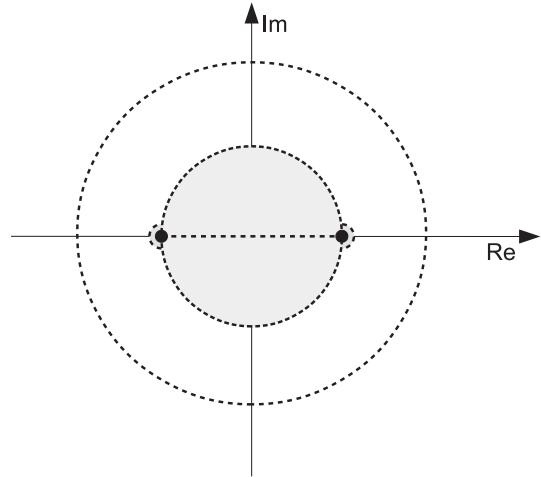

Fig. 2. Integration path modification for causal derivative.

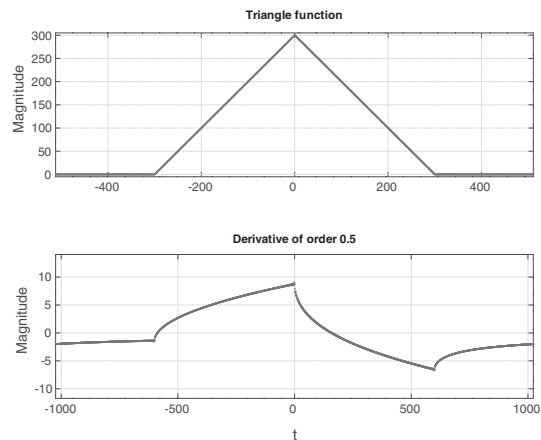

Fig. 3. Derivative of order $\alpha = 0.5$ of a triangle function with $h = 1$.

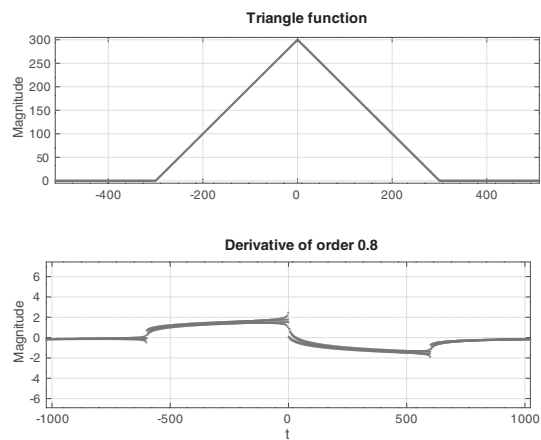

Fig. 4. Derivative of order $\alpha = 0.8$ of a triangle function with $h = 1$.

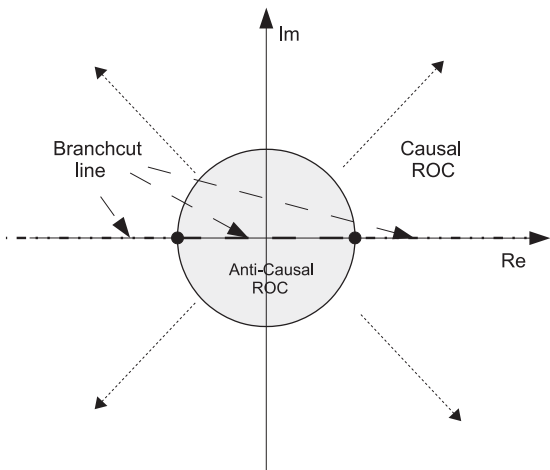

Fig. 1. ROC for causal and anti-causal derivatives and branchcut points and lines.

According to what we just wrote we can extend the above definitions to include sinusoids. We define the derivative of $x(n) = e^{i\omega n}, n \in \mathbb{Z}$, through

$$D_{f,b} e^{i\omega n} = \left[\frac{2}{h} \tan\left(\frac{\omega}{2}\right)\right]^\alpha e^{i\omega n}, \quad |\omega| < \pi, \quad (24)$$

independently of considering the forward or backward derivatives.

Definition 13. For a function having discrete-time Fourier transform (6), the bilinear derivative is expressed as:

$$D_{f,b} x(n) = \frac{1}{2\pi} \int_{-\pi}^{\pi} X(e^{i\omega}) \left[\frac{2}{h} \tan\left(\frac{\omega}{2}\right) \right]^{\alpha} e^{i\omega n} d\omega \quad (25)$$

that is suitable for implementations with the FFT. According to the existence conditions of the FT, we can say that, if $x(n)$ is absolutely summable, then the derivative (25) exists.

Properties of the derivatives

We present the main properties of the above derivatives. The proofs are easily obtained from the corresponding FT.

1. *Linearity*

The linearity property of the fractional derivative is straightforward from the above formulae.

2. *Time shift*

The derivative operators are shift invariant:

$$D_{f,b} x(n - n_0) = D_{f,b} x(m) \Big|_{m=n-n_0}$$

This property is immediately obtained from (20) or (22) as a consequence of the shift property of the Z transform $Z[x(n - n_0)] = X(z)z^{-n_0}$, $n_0 \in \mathbb{Z}$

3. *Additivity and Commutativity of the orders*

Let α and β be two real values. Then

$$D^{\alpha} [D^{\beta} x(n)] = D^{\beta} [D^{\alpha} x(n)] = D^{\alpha+\beta} x(n)$$

To prove this relation it is enough to observe that, in the forward case, we have $\left(\frac{2}{h} \frac{1-z^{-1}}{1+z^{-1}}\right)^{\alpha} \left(\frac{2}{h} \frac{1-z^{-1}}{1+z^{-1}}\right)^{\beta} = \left(\frac{2}{h} \frac{1-z^{-1}}{1+z^{-1}}\right)^{\alpha+\beta}$ and that the product is commutative. For the backward derivative, the situation is identical.

4. *Neutral element*

This comes from the additivity property by putting $\beta = -\alpha$,

$$D_{f,b}^{\alpha} [D_{f,b}^{-\alpha} f(n)] = D^0 f(n) = f(n).$$

This result is very important because it states the existence of inverse derivative.

5. *Inverse element*

The existence of neutral necessarily implies that there is always an inverse element: for every α order derivative, there is always a $-\alpha$ order derivative given by the same formula and so it does not need joining any primitivation constant. We adopt the designation “derivative” for positive orders and “anti-derivative” for negative ones.

6. *Associativity of the orders*

Let α, β , and κ be three real values. Therefore, we can write:

$$D^{\kappa} [D^{\alpha} D^{\beta}] x(n) = D^{\kappa+\alpha+\beta} x(n) = D^{\alpha+\beta+\kappa} f(n) = D^{\alpha} [D^{\beta+\kappa}] x(n)$$

as a consequence of the additivity.

7. *Derivative of the convolution*

Let $x(n) * y(n) = \sum_{k=-\infty}^{\infty} x(k)y(n - k)$ be the discrete-time convolution. Its ZT is $X(z)Y(z)$. Since we can write

$$\begin{aligned} \left(\frac{2}{h} \frac{1-z^{-1}}{1+z^{-1}}\right)^{\alpha} [X(z)Y(z)] &= \left\{ \left(\frac{2}{h} \frac{1-z^{-1}}{1+z^{-1}}\right)^{\alpha} X(z) \right\} Y(z) \\ &= X(z) \left\{ \left(\frac{2}{h} \frac{1-z^{-1}}{1+z^{-1}}\right)^{\alpha} Y(z) \right\}, \end{aligned}$$

we conclude that

$$D_f[x(n) * y(n)] = [D_f x(n)] * y(n) = x(n) * [D_f y(n)].$$

For the backward derivative of the convolution, we obtain an identical result.

Time formulations

In the previous sub-section, we introduced the derivatives using a formulation based on the ZT. Here we obtain the corresponding time framework, getting formulae similar to the Grünwald-Letnikov derivatives. From the binomial series [2]

$$(1 \pm w)^a = \sum_{k=0}^{\infty} \frac{(\mp 1)^k (-a)_k}{k!} w^k, \quad |w| < 1,$$

we conclude that the TF in (16) and (18) can be expressed as power series,

$$\left(\frac{1-z^{-1}}{1+z^{-1}}\right)^{\alpha} = \sum_{k=0}^{\infty} \psi_k^{\alpha} z^{-k}, \quad |z| > 1,$$

where ψ_k^{α} , $k = 0, 1, \dots$, is the inverse ZT of $\left(\frac{1-z^{-1}}{1+z^{-1}}\right)^{\alpha}$ and represents the impulse response (IR) corresponding to the TF.

Let the discrete convolution be defined by

$$x(n) * y(n) = \sum_{k=-\infty}^{\infty} x(k)y(n - k), \quad n \in \mathbb{Z}.$$

The IR, ψ_k^{α} , $k = 0, 1, \dots$, is obtained as the discrete convolution of the binomial coefficients sequence:

$$\psi_k^{\alpha} = \frac{(-\alpha)_k}{k!} * \frac{(-1)^k (\alpha)_k}{k!} = \sum_{m=0}^k \frac{(-\alpha)_m}{m!} \frac{(-1)^{k-m} (\alpha)_{k-m}}{(k-m)!}, \quad k \in \mathbb{Z}_0^+. \quad (26)$$

Performing this discrete convolution we obtain the following results

1. The sequence ψ_k^{α} , $k = 0, 1, \dots$, that is obtained as the discrete convolution of two causal sequences, is causal and, therefore, is null for $k < 0$. We will assume it below.
2. For any $\alpha \in \mathbb{R}$, we have

$$\psi_k^{-\alpha} = (-1)^k \psi_k^{\alpha}, \quad k \in \mathbb{Z}_0^+ \quad (27)$$

The proof is immediate from (26).

3. *Initial value*

From the initial value theorem of the ZT, it is immediate that $\psi_0^{\alpha} = 1$ independently of the order.

4. *Final value*

Let $\alpha \leq 0$. From the final value of the ZT,

$$\psi_{\infty}^{\alpha} = \lim_{z \rightarrow 1} (z - 1) \left(\frac{1 - z^{-1}}{1 + z^{-1}}\right)^{\alpha}$$

that is 0, if $-1 \leq \alpha \leq 0$, and 2, if $\alpha = -1$. For $\alpha < -1$ the sequence grows up to ∞ . For $\alpha > 0$ we apply (27).

5. If $\alpha \in \mathbb{R}$ but $\alpha \notin \mathbb{Z}^-$, then

$$\psi_k^{\alpha} = (-1)^k \frac{(\alpha)_k}{k!} \sum_{m=0}^k \frac{(-\alpha)_m (-k)_m}{(-\alpha - k + 1)_m} \frac{(-1)^m}{m!}, \quad k \in \mathbb{Z}_0^+ \quad (28)$$

6. Letting $\alpha = N$ in (28), we get

$$\psi_k^N = (-1)^k \frac{(N)_k}{k!} \sum_{m=0}^{\min(k,N)} \frac{(-N)_m (-k)_m}{(-N - k + 1)_m} \frac{(-1)^m}{m!}, \quad k \in \mathbb{Z}_0^+ \quad (29)$$

7. If $\alpha \in \mathbb{Z}^-$, set $\alpha = -N$, $N \in \mathbb{Z}^+$. We use

$$\psi_k^{-N} = \sum_{m=0}^k (-1)^m \frac{(-N)_m}{m!} \frac{(N)_{k-m}}{(k-m)!}$$

to obtain

$$\psi_k^{-N} = \frac{(N)_k}{k!} \sum_{m=0}^{\min(k,N)} \frac{(-N)_m (-k)_m}{(-N-k+1)_m} \frac{(-1)^m}{m!}, \quad k \in \mathbb{Z}_0^+. \quad (30)$$

Comparing (30) with (29), we conclude that they differ only in the factor $(-1)^k$, $k \in \mathbb{Z}_0^+$

8. A recursion

Let $\Psi(z) = \mathcal{Z}[\psi_k^z] = \left(\frac{1-z^{-1}}{1+z^{-1}}\right)^\alpha$. As $D\Psi(z) = -\sum_n (n-1)\psi_{n-1}^z z^{-n}$ and $D\Psi(z) = \alpha \left(\frac{1-z^{-1}}{1+z^{-1}}\right)^\alpha \left(\frac{1+z^{-1}}{1-z^{-1}}\right) D\left(\frac{1-z^{-1}}{1+z^{-1}}\right)$, after some algebraic manipulation we obtain:

$$\psi_k^z = -\frac{2\alpha}{k} \psi_{k-1}^z + \left(1 - \frac{2}{k}\right) \psi_{k-2}^z, \quad k \geq 2, \quad (31)$$

with $\psi_0^z = 1$ and $\psi_1^z = -2\alpha$.

This recursion shows that, if $\alpha < 0$, then ψ_k^z is a positive sequence. As consequence, attending to (27), the sequence corresponding to positive orders is always oscillating: successive values have different sign.

9. Relation with the Hypergeometric function

The first factor in (28), namely $(-1)^k \frac{(\alpha)_k}{k!}$, represents the binomial coefficient, while the second is a sequence from the Gauss Hypergeometric function

$$f_n = \sum_{m=0}^k \frac{(-\alpha)_m (-k)_m}{(-\alpha-k+1)_m} \frac{(-1)^m}{m!} = {}_2F_1(-\alpha, -k; 1-k-\alpha; -1), \quad n \in \mathbb{Z}_0^+. \quad (32)$$

This sequence verifies a second order recurrence [18]:

$$\begin{aligned} &(-\alpha-n+2)(-\alpha-n+1)f_n \\ &= -2\alpha(-\alpha-n+2)f_{n-1} + (n-1)(n-2)f_{n-2}, \quad n \geq 2, \end{aligned} \quad (33)$$

with initial values $f_0 = 1$ and $f_1 = 2$.

We can rewrite (33) as

$$f_n = \frac{2\alpha}{\alpha+n-1} f_{n-1} \frac{(n-1)(n-2)}{(\alpha+n-1)\alpha+n-2} f_{n-2}. \quad (34)$$

If we consider $g_n = \frac{(\alpha+1)_{n-1}}{(n-1)!} f_n$, $n \geq 1$, $g_0 = 0$ and $g_1 = 2$, then we obtain [18]

$$g_n = \frac{2\alpha}{n-1} g_{n-1} + g_{n-2}, \quad n \geq 2, \quad (35)$$

that is a polynomial of degree $n-1$ in α . Inserting (35) into (34) and the resulting expression in (28), we obtain

$$\psi_k^z = (-1)^k \frac{\alpha}{k} g_k, \quad k > 0, \quad (36)$$

where $\psi_0^z = 1$ and g_n is given by (35) with $g_1 = 2$.

Substituting (35) in (36) we obtain (31), as expected.

10. For a fixed $k \in \mathbb{Z}$, ψ_k^z is a polynomial in α of degree k .

As pointed above, ψ_0^z and ψ_1^z are polynomials of degrees 0 and 1, respectively. Assume that ψ_{k-1}^z has degree $k-1$. Then, the first term in right hand side in (31) ensures that ψ_k^z has degree k . As $\psi_0^z = 1$ and $\psi_1^z = -2\alpha$, recursion (31) shows that the independent coefficient of such polynomial is null for $k > 0$.

11. The coefficient of α^k decreases with increasing k .

For simplifying the proof, let $\psi_k^z = \sum_{m=1}^k p_m \alpha^m$ and $\psi_{k-1}^z = \sum_{m=1}^{k-1} q_m \alpha^m$. From (31) we conclude that $p_k = -\frac{2\alpha}{k} q_{k-1}$, because the second term in the right hand side of (31) only affects the lower order coefficients of the polynomial. As this happens for $k = 2, 3, \dots$, we can write

$$p_k = (-1)^k \frac{2^k}{k!}$$

that decreases with k . In fact, after simplifying the common factors between 2^k and $k!$, the denominator is the largest odd divisor of $n!$. The numerator is always a power of 2 corresponding to the factors that were not used when removing the common factors (see below 37) [6].

Example 2. We are going to present $\psi_k^{\pm N}$ for some values of $N \in \mathbb{Z}^+$ and for any real order obtained by recursive computation.

1. $N = 1$

$$\psi_k^1 = \begin{cases} 0 & k < 0 \\ 1 & k = 0 \\ 2(-1)^k & k > 0 \end{cases}$$

$$\psi_k^{-1} = \begin{cases} 0 & k < 0 \\ 1 & k = 0 \\ 2 & k > 0 \end{cases}$$

2. $N = 2$

$$\psi_k^2 = \begin{cases} 0 & k < 0 \\ 1 & k = 0 \\ (-1)^k 4k & k > 0 \end{cases}$$

$$\psi_k^{-2} = \begin{cases} 0 & k < 0 \\ 1 & k = 0 \\ 4k & k > 0 \end{cases}$$

3. For any negative order $-\alpha$, with $\alpha > 0$

Using the recursion (35) with $\psi_0^{-\alpha} = 1$ and $\psi_1^{-\alpha} = 2\alpha$, we obtain successively:

$$\begin{aligned} \psi_2^{-\alpha} &= 2\alpha^2 \\ \psi_3^{-\alpha} &= \frac{4}{3}\alpha^3 + \frac{2}{3}\alpha \\ \psi_4^{-\alpha} &= \frac{2}{3}\alpha^4 + \frac{4}{3}\alpha^2 \\ \psi_5^{-\alpha} &= \frac{4}{15}\alpha^5 + \frac{20}{15}\alpha^3 + \frac{6}{15}\alpha \\ \psi_6^{-\alpha} &= \frac{4}{45}\alpha^6 + \frac{40}{45}\alpha^4 + \frac{46}{45}\alpha^2 \\ \psi_7^{-\alpha} &= \frac{8}{315}\alpha^7 + \frac{140}{315}\alpha^5 + \frac{392}{315}\alpha^3 + \frac{90}{315}\alpha \\ \psi_8^{-\alpha} &= \frac{2}{315}\alpha^8 + \frac{56}{315}\alpha^6 + \frac{308}{315}\alpha^4 + \frac{264}{315}\alpha^2 \end{aligned} \quad (37)$$

In Fig. 5 we depict the values of ψ_k^z , $k = 0, 1, \dots, 500$ and $\alpha = -0.5k$, $k = 1, 2, \dots, 6$.

Similarly, for positive orders $\alpha = 0.2k$, $k = 1, 2, \dots, 6$, the bilinear sequences are plotted in Fig. 6.

Remark 3. In previous works, ARMA approximations to these sequences were proposed [8,9,5]. Nonetheless, we will not consider them here.

Definition 14. In agreement with the meaning attributed to the sequence ψ_k^z , $k = 0, 1, \dots$, we define the α -order forward and backward derivatives as

$$D_f^{(\alpha)} x(n) = \left(\frac{2}{h}\right)^\alpha \sum_{k=0}^{\infty} \psi_k^z x(n-k) \quad (38)$$

and

$$D_b^{(\alpha)} x(n) = e^{i\alpha\pi} \left(\frac{2}{h}\right)^\alpha \sum_{k=0}^{\infty} \psi_k^z x(n+k). \quad (39)$$

The use of the terms *forward* and *backward* is due to the “time flow”, from past to future or the reverse [10]. This terminology is the reverse of the one used in some mathematical literature.

We can remove the exponential factor, $e^{i\alpha\pi}$, in (39) to obtain a right derivative. In the following we will consider the causal

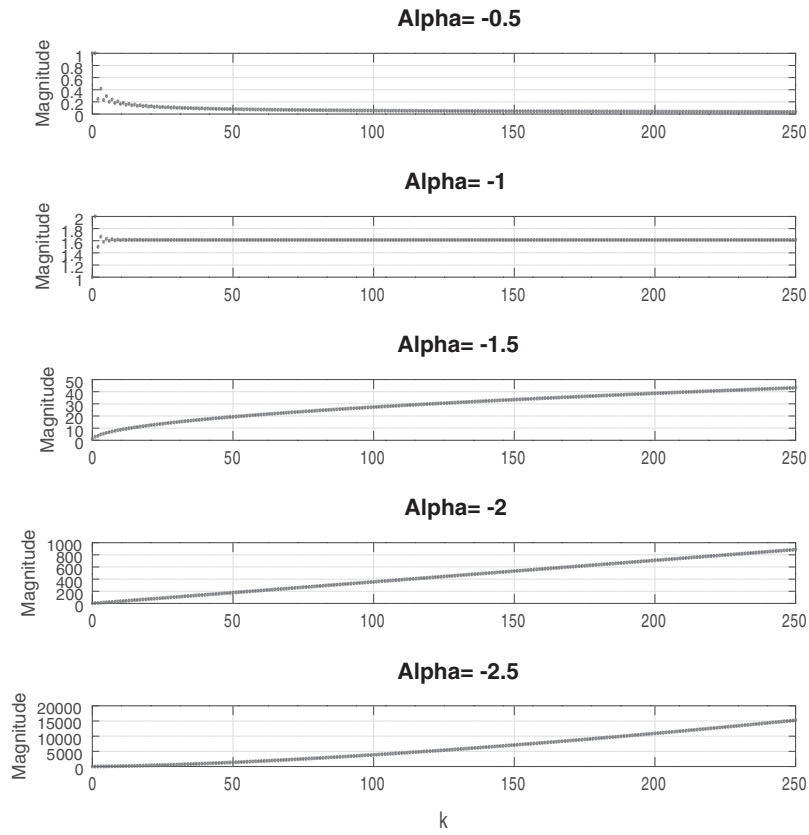

Fig. 5. Bilinear sequences corresponding to orders $\alpha = -0.5k$, $k = 1, 2, \dots, 5$.

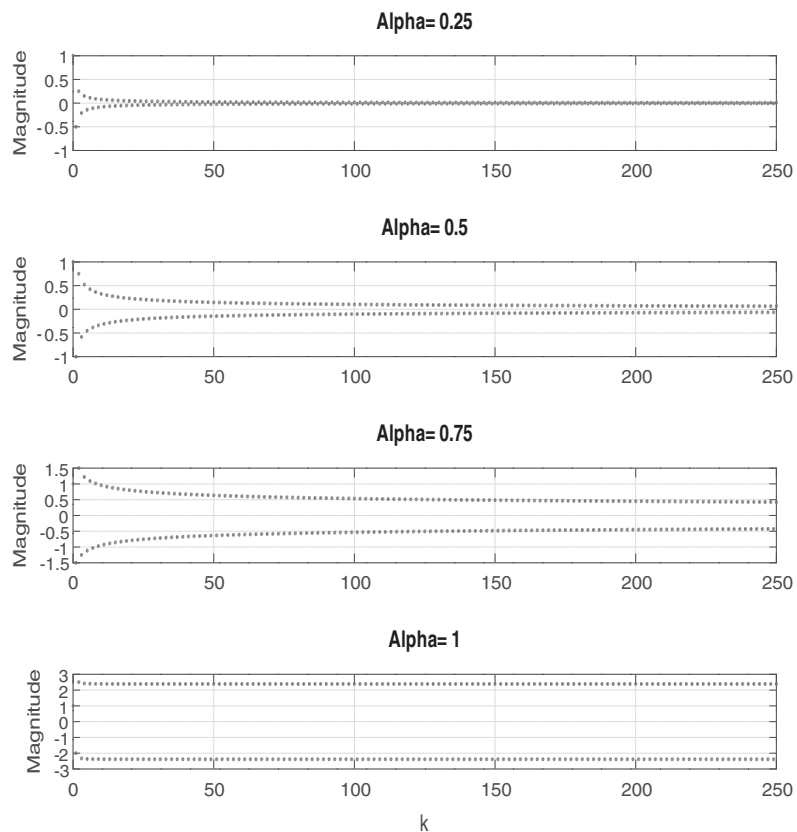

Fig. 6. Bilinear sequences corresponding to orders $\alpha = 0.25k$, $k = 1, 2, \dots, 4$.

derivative (38) represented by the simplified notation D^z and with ZT given by (21).

Other properties.

- The first is causal while the second is anti-causal.

In fact, if $x(n) = 0, n < n_0 \in \mathbb{Z}$, then $D_f^{(\alpha)}x(n) = 0, n < n_0$ and we obtain

$$D_f^{(\alpha)}x(n) = \left(\frac{2}{h}\right)^{\alpha} \sum_{k=0}^{n-n_0} \psi_k^z x(n-k) \tag{40}$$

that is null for $n < n_0$. For the backward the proof is similar using $x(n) = 0, n > n_0 \in \mathbb{Z}$, leading to

$$D_b^{(\alpha)}x(n) = e^{i\alpha\pi} \left(\frac{2}{h}\right)^{\alpha} \sum_{k=0}^{\alpha-n+n_0} \psi_k^z x(n+k) \tag{41}$$

that is null for $n > n_0$.

- Fractional derivative of the impulse

Let introduce the Kronecker impulse, $\delta(n), n \in \mathbb{Z}$, by

$$\delta(n) = \begin{cases} 1 & n = 0 \\ 0 & n \neq 0 \end{cases}.$$

The Heaviside discrete unit step is usually defined by

$$\varepsilon(n) = \begin{cases} 1 & n \geq 0 \\ 0 & n < 0 \end{cases}.$$

and its ZT is given by

$$\mathcal{Z}[\varepsilon(n)] = \frac{1}{1-z^{-1}}, |z| > 1.$$

As we can see, the derivative of any order of the Kronecker impulse is essentially given by the ψ_n^z coefficients. In fact, from (38) we get

$$D^z \delta(n) = \left(\frac{2}{h}\right)^{\alpha} \psi_n^z \varepsilon(n), \tag{42}$$

where $\varepsilon(n)$ is used to express the right behaviour of the derivative of the delta, stating the causality of the operator.

- Fractional derivative of the unit step

The function ψ_n^{-1} , introduced in Example 2, is a modified version of the unit step. It is straightforward to confirm that

$$\psi_n^{-1} = 2\varepsilon(n) - \delta(n).$$

with ZT $\mathcal{Z}[\psi_n^{-1}] = \frac{h}{2} \frac{1+z^{-1}}{1-z^{-1}}, |z| > 1$, as expected. According to the above properties, we can obtain the fractional derivative of the unit step function. We have

$$\varepsilon(n) = \frac{1}{2} \psi_n^{-1} + \frac{1}{2} \delta(n).$$

Consequently

$$D^z \varepsilon(n) = \frac{1}{2} \left(\frac{2}{h}\right)^{\alpha-1} \psi_n^{\alpha-1} + \frac{1}{2} \left(\frac{2}{h}\right)^{\alpha} \psi_n^{\alpha}.$$

- Fractional derivative of the ψ function

We are interested in computing the derivative of ψ_n^z , for any α with $n \in \mathbb{Z}$. From (42) and the additivity property, we can write

$$D^{\beta} D^{\alpha} \delta(n) = D^{\beta} \left[\left(\frac{2}{h}\right)^{\alpha} \psi_n^{\alpha} \right] = \left(\frac{2}{h}\right)^{\alpha+\beta} \psi_n^{\alpha+\beta} \varepsilon(n)$$

that leads to

$$D^{\beta} [\psi_n^{\alpha}] = \left(\frac{2}{h}\right)^{\beta} \psi_n^{\alpha+\beta} \varepsilon(n). \tag{43}$$

Backward compatibility

Often, discrete-time systems are viewed as mere approximations to the continuous-time counterpart. However, and as seen above, the discrete-time systems exist by themselves and have properties that are independent from, although similar to, the continuous-time analogues. Nonetheless, this observation does not prevent us from establishing a continuous path from each other. In fact, we can go from the discrete into the continuous domain by reducing the graininess. To see it, let us return to (20) and rewrite it as

$$D_f^{(\alpha)}x(nh) = \left(\frac{2}{h}\right)^{\alpha} \sum_{k=0}^{\infty} \psi_k^z x(nh - kh).$$

Assume that $x(nh)$ resulted from a continuous-time function $x(t)$ and define a new function, $y(t)$, by

$$y(t) = \left(\frac{2}{h}\right)^{\alpha} \sum_{k=0}^{\infty} \psi_k^z x(t - kh). \tag{44}$$

The LT of (44) is

$$Y(s) = \left(\frac{2}{h}\right)^{\alpha} \sum_{k=0}^{\infty} \psi_k^z e^{-khs} X(s) = \left(\frac{2}{h} \frac{1 - e^{-hs}}{1 + e^{-hs}}\right)^{\alpha} X(s), \tag{45}$$

where $Y(s) = \mathcal{L}[y(t)]$ and $X(s) = \mathcal{L}[x(t)]$. Knowing that $\lim_{h \rightarrow 0} \frac{1 - e^{-hs}}{h} = s$, we can write

$$Y(s) = s^{\alpha} X(s), \text{Re}(s) > 0,$$

meaning that $Y(s)$ is the LT of the (continuous-time) derivative of $x(t)$. This relation states a compatibility between the new formulation described above and the well known results from the continuous-time derivative formulation [12]. If we used the backward formulation, we would obtain the same result, but with a ROC valid for $\text{Re}(s) < 0$. Taking in account the above equations and (38), we conclude that, for $t \in \mathbb{R}$, we can write:

$$D_f^{(\alpha)}x(t) = \lim_{h \rightarrow 0} \left(\frac{2}{h}\right)^{\alpha} \sum_{k=0}^{\infty} \psi_k^z x(t - kh). \tag{46}$$

Similarly, we can obtain from (39)

$$D_b^{(\alpha)}x(t) = e^{i\alpha\pi} \lim_{h \rightarrow 0} \left(\frac{2}{h}\right)^{\alpha} \sum_{k=0}^{\infty} \psi_k^z x(t + kh) \tag{47}$$

Relations (46) and (47) state two new ways of computing the continuous-time fractional derivative that are similar to the Grünwald-Letnikov derivatives. However, it may be interesting to remark that we can compute derivatives with (44) instead of (22).

The differential discrete-time linear systems

The above derivatives lead us to consider systems defined by constant coefficient differential equations with the general form

$$\sum_{k=0}^N a_k D^{\alpha_k} y(n) = \sum_{k=0}^M b_k D^{\beta_k} u(n) \tag{48}$$

with $a_N = 1$. The operator D is the forward (or backward) derivative above defined, assuming orders α_k and $\beta_k, k = 0, 1, 2, \dots$. The coefficients a_k and $b_k, k = 0, 1, 2, \dots$ are real numbers and N and M represent any given positive integers. Let $g(n)$ be the IR of the system defined by (48) that is, $v(n) = \delta(n)$. The output is the convolution of the input and the IR,

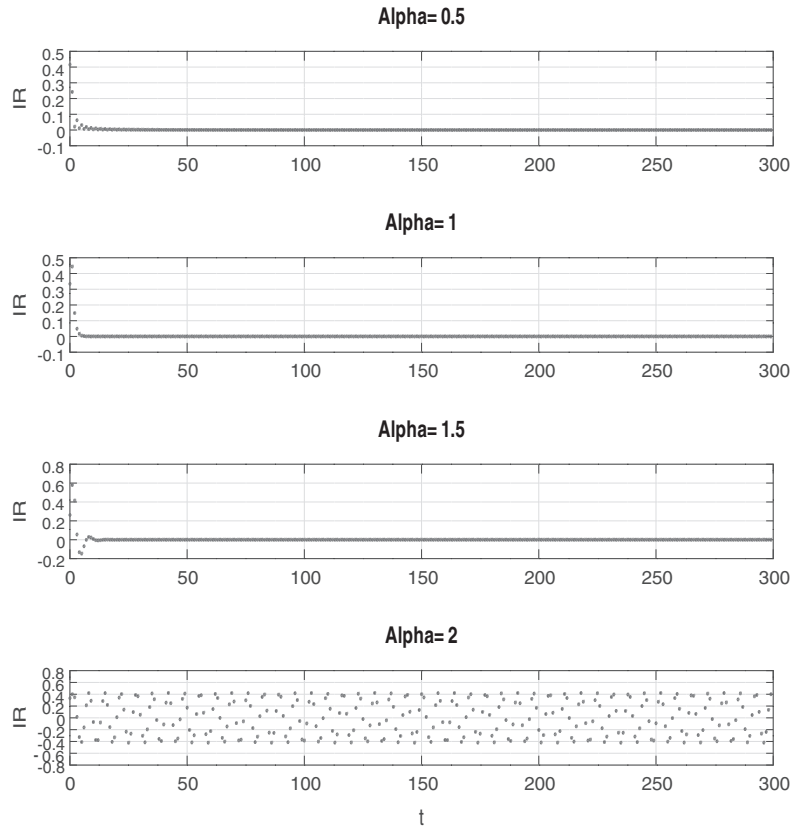

Fig. 7. Impulse responses corresponding to (53) for orders $\alpha = 0.5k$, $k = 1, 2, \dots, 4$.

$$y(n) = g(n) * v(n). \tag{49}$$

If $v(n) = z^n$, then the output is given by:

$$y(n) = z^n \left[\sum_{n=-\infty}^{\infty} g(n) z^{-n} \right].$$

The summation expression will be called **transfer function** as usually and it is the ZT, $G(z)$, of the IR.

With the definition of forward derivative and mainly formula (21) we write

$$G(z) = \frac{\sum_{k=0}^M b_k \left(\frac{2}{h} \frac{1-z^{-1}}{1+z^{-1}} \right)^{\beta_k}}{\sum_{k=0}^N a_k \left(\frac{2}{h} \frac{1-z^{-1}}{1+z^{-1}} \right)^{\alpha_k}}, \quad |z| > 1, \tag{50}$$

for the causal case, and

$$G(z) = \frac{\sum_{k=0}^M b_k \left(\frac{2}{h} \frac{z-1}{z+1} \right)^{\beta_k}}{\sum_{k=0}^N a_k \left(\frac{2}{h} \frac{z-1}{z+1} \right)^{\alpha_k}}, \quad |z| < 1, \tag{51}$$

for the anti-causal case. We can give to expressions (50) and (51) a form that states their similarity with the classic fractional linear systems [13,4]. For example, for the first, let $v = \left(\frac{2}{h} \frac{1-z^{-1}}{1+z^{-1}} \right)$. We have

$$G(v) = \frac{\sum_{k=0}^M b_k v^{\beta_k}}{\sum_{k=0}^N a_k v^{\alpha_k}} \tag{52}$$

Remark 4. It is important to note that the factors $\left(\frac{2}{h} \right)^{\alpha_k}$, $k = 1, 2, \dots$, do not have any important role in the computations. Therefore, they can be merged with a_k and b_k coefficients.

Example 3. Consider the simple system with transfer function

$$G(v) = \frac{1}{v^\alpha + 1}. \tag{53}$$

In Fig. 7 we represent the impulse responses for several values of the order, $\alpha = 0.25k$, $k = 1, 2, \dots, 6$.

It is interesting to verify that all the IR assume a finite value at the origin, contrarily to the continuous-time system analog to (53) described by $G(v) = \frac{1}{v^\alpha + 1}$, $Re(v) > 0$.

Conclusions

In this paper, we introduced new discrete-time fractional derivatives based on the bilinear transformation. We obtained both time and frequency representations. The corresponding impulse responses are always finite, contrarily to their continuous-time analogs. We illustrate the behaviour of the forward derivative through the computation of the impulse response of a simple system.

Compliance with Ethics Requirements

This article does not contain any studies with human or animal subjects.

Declaration of Competing Interest

The authors declare that they have no known competing financial interests or personal relationships that could have appeared to influence the work reported in this paper.

Acknowledgements

This work was partially funded by National Funds through the Foundation for Science and Technology of Portugal, under the projects UIDB/00066/2020.

References

- [1] Bohner M, Peterson A. *Dynamic Equations on Time Scales: an introduction with applications*. Boston: Birkäuser; 2001.
- [2] Henrici P. *Applied Computational Complex Analysis*. vol. 2, Wiley-Interscience Publication; 1991.
- [3] Hilger S. Analysis on measure chains - a unified approach to continuous and discrete calculus. *Res. Math.* 1990;18(1–2):18–56.
- [4] Magin R, Ortigueira MD, Podlubny I, Trujillo J. On the fractional signals and systems. *Signal Process* 2011;91(3):350–71.
- [5] Maione G, Lazarević MP. On the symmetric distribution of interlaced zero-pole pairs approximating the discrete fractional tustin operator. In: 2019 IEEE international conference on Systems, Man and Cybernetics (SMC), Bari, Italy; 2019. p. 2578–83.
- [6] The on-line Encyclopedia of Integer Sequences, <https://oeis.org/book.html> [accessed October 2019].
- [7] Oppenheim AV, Schaffer RW. *Discrete-time signal processing*. 3rd ed. Upper Saddle River, USA: Prentice Hall Signal Processing; 2009.
- [8] Ortigueira MD, Serralheiro AJ. A new least-squares approach to differintegration modeling. *Signal Process* 2006;86(10):2582–91.
- [9] Ortigueira MD, Serralheiro AJ. Pseudo-fractional ARMA modelling using a double Levinson recursion. *IET Control Theory Appl* 2007;1(1):173.
- [10] Ortigueira MD. *Fractional calculus for scientists and engineers*. Springer: Lecture Notes in Electrical Engineering, volume 84; 2011. doi:10.1007/978-94-007-0747-4).
- [11] Ortigueira MD, Coito FJV, Trujillo JJ. Discrete-time differential systems. *Signal Process* 2015;107(2015):198–217.
- [12] Ortigueira MD, Machado JT. Which derivative? *Fractal Fractional* 2017;1(1):3.
- [13] Petráš I. *Fractional-order nonlinear systems: modeling, analysis and simulation*. Springer; 2011.
- [14] Petráš I. A new discrete approximation of the fractional-order operator. In: *Proceedings of the 13th International Carpathian Control Conference (ICCC)*, May. p. 547–51.
- [15] Proakis JG, Manolakis DG. *Digital signal processing: principles, algorithms, and applications*. Prentice-Hall; 2006.
- [16] Roberts MJ. *Signals and systems: analysis using transform methods and matlab*. International ed. McGraw-Hill; 2003.
- [17] Tustin A. A method of analysing the behaviour of linear systems in terms of time series. *J Inst Electrical Eng – Part IIA: Automat Regul Servo Mech* 1947;94(1):130–42.
- [18] Strehl V. Personal mail communication; 2003.