



Liliana Andreia Amaro Rodrigues

Licenciatura em Ciências da Engenharia Química e Bioquímica

**Development of a "green process" for the
isolation of natural functional extracts with
anti-cancer activity - Application of high-
pressure technology**

Dissertação para obtenção do Grau de Mestre em
Engenharia Química e Bioquímica

Orientador: Catarina Duarte, Ph.D, IBET/ITQB-UNL
Co-orientador: Ana Teresa Serra, Ph.D, IBET/ITQB-UNL

Júri:

Presidente: Prof. Doutor Mário Fernando José Eusébio
Arguente: Prof. Doutora Susana Filipe Barreiros
Vogal: Doutora Catarina Maria Martins Duarte



FACULDADE DE
CIÊNCIAS E TECNOLOGIA
UNIVERSIDADE NOVA DE LISBOA

Março 2014

Liliana Andreia Amaro Rodrigues

Licenciatura em Ciências da Engenharia Química e Bioquímica

**Development of a "green process" for the
isolation of natural functional extracts with anti-
cancer activity - Application of high-pressure
technology**

Dissertação para obtenção do Grau de Mestre em
Engenharia Química e Bioquímica

Orientador: Catarina Duarte, Ph.D, IBET/ITQB-UNL
Co-orientador: Ana Teresa Serra, Ph.D, IBET/ITQB-UNL

Júri:

Presidente: Prof. Doutor Mário Fernando José Eusébio
Arguente: Prof. Doutora Susana Filipe Barreiros
Vogal: Doutora Catarina Maria Martins Duarte



Março 2014

Development of a “green process” for the isolation of natural functional extracts with anti-cancer activity – Application of high-pressure technology

Copyright Liliana Andreia Amaro Rodrigues, FCT/UNL, UNL

A Faculdade de Ciências e Tecnologia e a Universidade Nova de Lisboa têm o direito, perpétuo e sem limites geográficos, de arquivar e publicar esta dissertação através de exemplares impressos reproduzidos em papel ou de forma digital, ou por qualquer outro meio conhecido ou que venha a ser inventado, e de a divulgar através de repositórios científicos e de admitir a sua cópia e distribuição com objetivos educacionais ou de investigação, não comerciais, desde que seja dado crédito ao autor e editor.

Acknowledgments

Gostaria de agradecer a todos aqueles que, direta ou indiretamente, contribuíram para a realização deste trabalho.

Em primeiro lugar, à Doutora Catarina Duarte, por me ter dado a oportunidade de desenvolver este trabalho no laboratório de Nutracêuticos e Libertação Controlada. Agradeço também toda a orientação prestada, pelo seu constante otimismo e palavras de incentivo e apoio.

À Doutora Ana Teresa Serra, agradeço toda a orientação e apoio prestados. Obrigada pelas boas ideias e pela tua paciência e constante disponibilidade.

Agradeço a todos os membros e colegas do laboratório de Nutracêuticos e Libertação Controlada e de forma especial:

À Inês Silva que realizou todos os ensaios de citotoxicidade e atividade antiproliferativa. Muito obrigada por toda a tua ajuda e disponibilidade constante.

Ao Agostinho Alexandre, por todos os conhecimentos que me transmitiu, pelos comentários e sugestões. Obrigada pela tua preocupação e companhia.

À Joana Poejo, por toda a ajuda prestada nos ensaios de atividade antioxidante. Muito obrigada pela tua disponibilidade e paciência.

À Ana Nunes, por me ter acompanhado no início do projeto.

Ao Daniel D. Lopes, à Sara Nunes, à Cátia Carmo e à Vanessa Gonçalves. Obrigada pela vossa companhia, amizade e preocupação.

Agradeço à Doutora Maria do Rosário Bronze por todo o apoio na parte analítica do trabalho e pela disponibilidade constante.

Agradeço também ao Cláudio Almeida e ao Professor Luís Vilas Boas pela disponibilidade que sempre demonstraram.

À Ana, à Catarina, à Margarida, à Sara e ao Tiago, que me acompanharam desde o início do meu percurso académico. Obrigada pela vossa amizade, apoio e preocupação e por todos os bons momentos que passámos juntos.

Aos meus amigos David, Marco e Ricardo por todo o apoio, amizade e preocupação.

Ao Francisco, que mesmo estando longe, conseguiu estar sempre presente para me apoiar nas alturas mais difíceis. Obrigada pela tua amizade e palavras de apoio. Tens o otimismo que me falta!

À minha família e em especial aos meus pais, que tudo fizeram para me apoiar durante todo o percurso académico, à minha irmã pelas palavras de incentivo e à minha avó pela constante preocupação.

A todos, muito obrigada!

Abstract

The knowledge of the healing power of some species of plants is ancient. Nowadays, the preference for natural products has increased, and with it, the interest in recover and isolate bioactive phytochemicals with potential health benefits.

The main goal of this thesis was to isolate anticancer bioactive compounds, namely terpenes and fatty acids, from Portuguese *Lavandula* (*L. angustifolia* and *L. stoechas*) and *Mentha* species (*M. spicata*, *M. piperita* var. *citrate* and *M. pulegium*), using supercritical fluid extraction (SFE).

All extractions were performed at 50°C and 250 bar in a two step methodology: a first step with supercritical CO₂, during 60 minutes, followed by a second step, with a mixture of CO₂ and ethanol (90:10 %v/v), for 180 minutes. Different fractions of the extracts were recovered every 30 minutes, and the resulting samples were characterized in terms of global yield (% g/g), screened for the presence of terpenes, by thin layer chromatography (TLC) and analyzed by gas chromatography coupled with mass spectrometry detection (GC-MS). Furthermore, ORAC, HORAC and HOSC assays were conducted for the determination of antioxidant activity. Cell-based assays in human HT-29 colorectal adenocarcinoma cells were also performed, in order to determine the potential of the extracts as cancer cell-growth inhibitors.

The fractions of the extract of *M. piperita* var. *citrate* presented the highest antioxidant activity, whereas the fractions of *L. angustifolia*, *L. stoechas* and *M. spicata* extracts revealed to be the most promising colorectal cancer cell-growth inhibitors. The bioactive responses were correlated with the phytochemical composition of the extracts, and the main compounds, such as camphor, fenchone, carvone, linoleic acid, among others, were highlighted. However, it is possible that the bioactivities were due to synergistic effects between several compounds.

Results of this thesis demonstrated that SFE is a reliable tool to extract anticancer bioactive components from some *Lavandula* and *Mentha* plants.

Keywords: Supercritical fluid extraction, *Lavandula* spp., *Mentha* spp., terpenes, antiproliferative activity, colorectal cancer.

Resumo

O conhecimento do poder curativo de certas espécies de plantas é muito antigo. Nos dias que correm, a preferência por produtos naturais aumentou e, com ela, o interesse em recuperar e isolar fitoquímicos bioativos com potenciais benefícios para a saúde.

Nesta tese pretendeu-se isolar compostos bioativos com atividade anticancerígena, nomeadamente terpenos e ácidos gordos, a partir de espécies de *Lavandula* (*L. angustifolia* e *L. stoechas*) e *Mentha* (*M. spicata*, *M. piperita* var. *citrata* e *M. pulegium*), utilizando extração com fluidos supercríticos (SFE).

Todas as extrações foram realizadas a 50°C e 250 bar utilizando uma metodologia de dois passos: um primeiro com CO₂ supercrítico, durante 60 minutos, seguido de um segundo com uma mistura de CO₂ e etanol (90:10 %v/v), durante 180 minutos. Os extratos foram recolhidos em diferentes frações em intervalos de 30 minutos e as amostras resultantes foram caracterizadas em termos de rendimento global (% g/g), analisadas por cromatografia em camada fina (TLC) e por cromatografia gasosa acoplada a espectrometria de massa (GC-MS). Posteriormente, foram realizados ensaios para determinação da atividade antioxidante, nomeadamente ORAC, HORAC e HOSC, bem como ensaios em células humanas de cancro colo-rectal (HT-29), de forma a determinar a atividade antiproliferativa dos extratos.

As frações do extrato de *M. piperita* var. *citrata* apresentaram a maior atividade antioxidante, enquanto que os extratos de *L. angustifolia*, *L. stoechas* e *M. spicata* revelaram ser os mais promissores em termos de atividade anticancerígena. As respostas bioativas foram correlacionadas com a composição fitoquímica dos extratos e os seus compostos maioritários, tais como a cânfora, fenchona, carvona e ácido linoleico foram destacados. No entanto, é possível que as bioatividades se devam a sinergias entre vários compostos.

Os resultados desta tese demonstraram que a SFE é uma ferramenta fidedigna para extrair compostos bioativos com atividade anticancerígena a partir de plantas do género *Lavandula* e *Mentha*.

Palavras-chave: Extração com fluidos supercríticos, *Lavandula* spp., *Mentha* spp, terpenos, atividade antiproliferativa, cancro colo-rectal.

Index

1.	Introduction	1
1.1.	Cancer worldwide	1
1.1.1.	Colorectal cancer.....	2
1.2.	Herbs and Spices: Their Role in Cancer Prevention and Treatment	4
1.2.1.	Phytochemicals and their health-promoting effects	7
1.3.	<i>Lavandula</i> and <i>Mentha</i> Species.....	13
1.3.1.	<i>Lavandula</i> spp.	13
1.3.2.	<i>Mentha</i> spp.	14
1.4.	Natural Health Products and Nutraceuticals	16
1.4.1.	Extraction of Bioactive Compounds	17
1.5.	Aim and structure of the thesis.....	23
2.	Materials and Methods	25
2.1.	Chemicals.....	25
2.2.	Raw material preparation	25
2.3.	Moisture content determination	26
2.4.	Supercritical Fluid Extraction (SFE) procedure	26
2.5.	Characterization of the extracts.....	28
2.5.1.	Terpenes and steroids detection by Thin Layer Chromatography (TLC)	28
2.5.2.	Identification and quantification of the extract's chemical components by Gas Chromatography – Mass Spectrometry (GC-MS).....	29
2.6.	Antioxidant activity.....	29
2.6.1.	Oxygen Radical Absorbance Capacity (ORAC).....	29
2.6.2.	Hydroxyl Radical Adverting Capacity (HORAC)	30
2.6.3.	Hydroxyl Radical Scavenging Capacity (HOSC)	31
2.6.4.	Lipophilic Oxygen Radical Absorbance Capacity (L-ORAC).....	31
2.7.	Cell-Based Assays.....	32
2.7.1.	Cell lines and culture.....	32
2.7.2.	Cytotoxicity assay	33
2.7.3.	Antiproliferative Assay	33
3.	Results and Discussion	35
3.1.	Development of natural extracts using supercritical fluid extraction.....	35
3.2.	Phytochemical characterization of the bioactive rich extracts	37
3.3.	Evaluation of the antioxidant activity of the natural extracts using chemical assays..	53
3.4.	Evaluation of the antiproliferative effect of the natural extracts in HT-29 cells.....	59
4.	Conclusions	65
5.	References	67
6.	Appendix	79
	Appendix A – Thin Layer Chromatography.....	79
	Appendix B – GC chromatograms.....	82

Index of figures

Figure 1.1 Endogenous and exogenous causes of cancer.	1
Figure 1.2 Schematic representation of part of the digestive system, including the colon and rectum.	3
Figure 1.3 Fundamental processes in promotion or inhibition of cancer development and progression, which can be influenced by food, nutrition, obesity and physical activity.	4
Figure 1.4 Potential mechanisms for cancer prevention with phytochemicals.	5
Figure 1.5 Different classes of terpenes.	10
Figure 1.6 Structural formulas of some fatty acids.	13
Figure 1.7 Pressure-temperature diagram for a pure component.	18
Figure 1.8 Schematic diagram of a basic supercritical fluid extraction system.	20
Figure 1.9 Structure of the thesis.	24
Figure 2.1 Schematic diagram of the supercritical fluid extraction apparatus.	27
Figure 3.1 TLC analysis of the natural extracts, obtained by SFE, to reveal terpenes and steroids.	38
Figure 3.2 Antioxidant capacity of the fractions A, B and C of <i>Lavandula</i> and <i>Mentha</i> extracts.	55
Figure 3.3 Hydrophilic and lipophilic antioxidant capacities tested by ORAC and L-ORAC assays.	59
Figure 3.4 Antiproliferative effect of the fractions A, B and C of <i>Lavandula</i> and <i>Mentha</i> extracts on HT-29 human colorectal adenocarcinoma cells (n=2).	61
Figure 3.5 Concentrations of the fractions A, B and C of the natural extracts required to decrease 50% of the cell viability (EC ₅₀), after an incubation period of 24h. (Data are means ± SD (n=2)).	62
Figure 6.1 TLC analysis of the <i>L. angustifolia</i> extract, obtained by SFE, to reveal terpenes and steroids.	79
Figure 6.2 TLC analysis of the <i>L. stoechas</i> extract, obtained by SFE, to reveal terpenes and steroids.	80
Figure 6.3 TLC analysis of the <i>M. spicata</i> extract, obtained by SFE, to reveal terpenes and steroids.	80
Figure 6.4 TLC analysis of the <i>M. piperita</i> var. <i>citrata</i> extract, obtained by SFE, to reveal terpenes and steroids.	81
Figure 6.5 TLC analysis of the <i>M. pulegium</i> extract, obtained by SFE, to reveal terpenes and steroids.	81

Figure 6.6 Chromatograms of the fractions of fresh extract of <i>L. angustifolia</i> .	82
Figure 6.7 Chromatograms of the fractions of the not fresh extract of <i>L. angustifolia</i> .	83
Figure 6.8 Chromatograms of the fractions of the extract of <i>L. stoechas</i> .	84
Figure 6.9 Chromatograms of the fractions of the extract of <i>M. spicata</i> .	85
Figure 6.10 Chromatograms of the fractions of the extract of <i>M. piperita</i> var. <i>citrata</i> .	86
Figure 6.11 Chromatograms of the fractions of the extract of <i>M. pulegium</i> .	87

Index of tables

Table 1.1 Cancer estimated incidence, mortality and prevalence worldwide in 2012 (excluding non-melanoma skin cancer). The data was estimated in thousands.	2
Table 1.2 Examples of bioactive components in commonly used herbs and spices.	6
Table 1.3 Major classes of plant chemicals and their subclasses.	8
Table 1.4 Multiple structures of monoterpenes.	11
Table 1.5 Range values of some physical properties of gases, liquids and supercritical fluids.	19
Table 1.6 Solubility of natural compounds in supercritical CO ₂ .	20
Table 1.7 Some SFE applications in natural products and food industries.	22
Table 1.8 Some SFE natural extracts applications.	22
Table 3.1 Natural matrices initial characterization: mean particle size, moisture content and global yield of the extracts obtained from the SFE performed.	37
Table 3.2 Mixtures of the fractions of the natural extracts, obtained by SFE, with similar profiles.	38
Table 3.3 Major extract constituents of <i>L. angustifolia</i> determined by GC-MS.	40
Table 3.4 Other extract constituents of <i>L. angustifolia</i> determined by GC-MS.	40
Table 3.5 Major extract constituents of <i>L. stoechas</i> determined by GC-MS.	42
Table 3.6 Other extract constituents of <i>L. stoechas</i> determined by GC-MS.	43
Table 3.7 Major extract constituents of <i>M. spicata</i> determined by GC-MS.	45
Table 3.8 Other extract constituents of <i>M. spicata</i> determined by GC-MS.	45
Table 3.9 Major extract constituents of <i>M. piperita</i> var. <i>citrata</i> determined by GC-MS.	48
Table 3.10 Other extract constituents of <i>M. piperita</i> var. <i>citrata</i> determined by GC-MS.	48
Table 3.11 Major extract constituents of <i>M. pulegium</i> determined by GC-MS.	51
Table 3.12 Other extract constituents of <i>M. pulegium</i> determined by GC-MS.	51
Table 3.13 Antioxidant activity of the fractions of the natural extracts obtained by SFE.	54
Table 3.14 Concentrations of SFE natural extract required to decrease 50% of the cell viability (EC50), after an incubation period of 24h. (Data are means \pm SD (n=2)).	60

List of abbreviations, acronyms and symbols

Abbreviation	Full form
AAPH	2',2'-azobis (2-amidinopropane) dihydrochloride
ACS	American Cancer Society
AICR	American Institute of Cancer Research
Caco-2	Caco-2 human colorectal adenocarcinoma cell line
CAE	Caffeic acid equivalents
CD	Cyclodextrin
CO ₂	Carbon dioxide
CP	Critical point
DMSO	Dimethyl sulphoxide
DNA	Deoxyribonucleic acid
EC50	Median effective concentration
EtOH	Ethanol
FBS	Fetal Bovine Serum
FL	Disodium Fluorescein
GC	Gas chromatographer
GC-MS	Gas Chromatography – Mass Spectrometry
HORAC	Hydroxyl Radical Adverting Capacity
HOSC	Hydroxyl Radical Scavenging Capacity
HP- β -CD	2-Hydroxypropyl- β -cyclodextrin
HT-29	HT-29 human colorectal adenocarcinoma cell line
L-ORAC	Lipophilic Oxygen Radical Absorbance Capacity
MTT	3-(4,5-Dimethylthiazol-2-yl)-2,5-diphenyltetrazolium bromide
NCI	National Cancer Institute
ORAC	Oxygen Radical Absorbance Capacity
PBS	Phosphate Buffer Saline
P _c	Critical pressure
Ret. Time	Retention time
SCF	Supercritical Fluid
SFE	Supercritical Fluid Extraction
Sim. Index	Similarity index
SPB	Sodium Buffer Saline
T _c	Critical temperature
TE	Trolox equivalents
TLC	Thin layer chromatography

Abbreviation	Full form
TP	Triple point
Trolox	6-hydroxy-2,5,7,8-tetramethylchroman-2-carboxylic acid
UV	Ultraviolet
WCRF / AICR	World Cancer Research Fund / American Institute of Cancer Research
WHO	World Health Organization

1. Introduction

1.1. Cancer worldwide

According to the World Health Organization (2014), cancer is among the leading causes of death worldwide, being most of these deaths caused by lung, liver, stomach, colorectal and breast cancers.

Cancer is the generic name given to a large group of diseases (more than 100 different kinds). Still, all types of cancer start due to a rapid and uncontrolled growth of abnormal cells. (ACS, 2012) This phenomenon is provoked by changes that occur in the genetic information of cells (DNA mutations). (AICR, 2013)

There are a number of different factors there are known causes of cancer. Those factors can be endogenous or exogenous (environmental). Some of them are outlined in Figure 1.1.

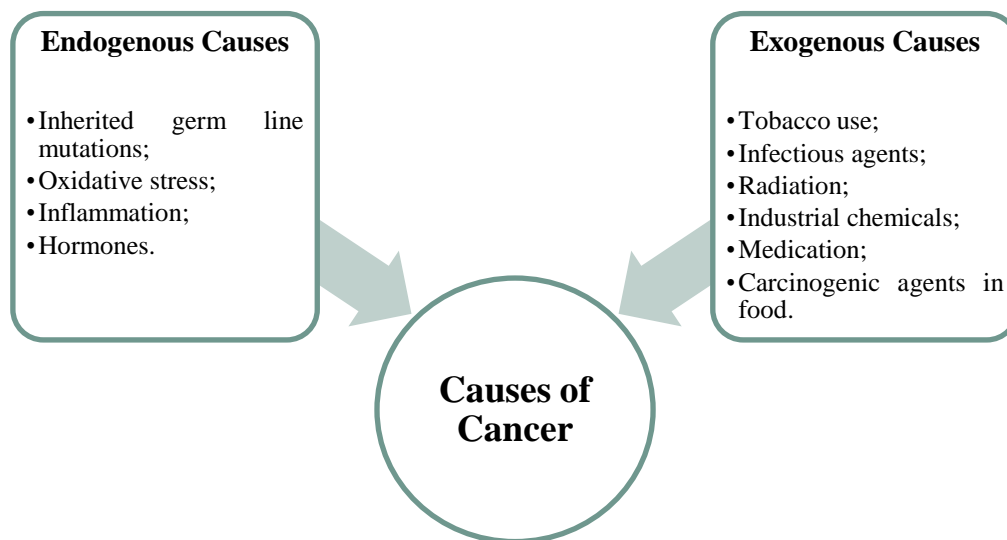

Figure 1.1 Endogenous and exogenous causes of cancer. (Adapted from WCRF / AICR, 2007)

According to the GLOBOCAN project, that estimates the incidence, the mortality and the prevalence of cancer worldwide, in 2012 there were about 14.1 million new cancer cases and the disease caused more than 8.2 million deaths (these numbers exclude non-melanoma skin cancer). More than 8 million of new cancer cases (representing 57% of the total cases) and about 5.3 million of the deaths provoked by cancer (which corresponds to 65% of the total cancer deaths) occurred in the less developed regions of the world. This data can be seen in detail in Table 1.1. (Ferlay et al., 2012) As reported by the American Cancer Society (2012), it is estimated that the cancer global incidence continues to grow, rising up to 21.4 million cases and 13.2 million deaths in 2030.

Table 1.1 Cancer estimated incidence, mortality and prevalence worldwide in 2012 (excluding non-melanoma skin cancer). The data was estimated in thousands. (Adapted from Ferlay et al., 2012)

	Men		Women		Both Sexes	
	Cases	Deaths	Cases	Deaths	Cases	Deaths
World	7427	4653	6663	3548	14090	8201
More developed regions	3244	1591	2832	1287	6076	2878
Less developed regions	4184	3062	3831	2261	8014	5323
WHO Africa region	265	205	381	250	645	456
WHO Americas region	1454	677	1429	618	2882	1295
WHO East Mediterranean region	263	191	293	176	555	367
WHO Europe region	1987	1080	1750	852	3737	1932
WHO South-East Asia region	816	616	908	555	1724	1171
WHO Western Pacific region	2642	1882	1902	1096	4543	2978
IARC membership (24 countries)	3706	1900	3354	1570	7060	3470
United States of America	825	324	779	293	1604	617
China	1823	1429	1243	776	3065	2206
India	477	357	537	326	1015	683
European Union (28 countries)	1446	715	1211	560	2657	1276

1.1.1. Colorectal cancer

Colorectal cancer is the third most common cancer among men (746.000 cases that corresponds to 10% of the total) and the second with respect to women (614.00 cases, corresponding to 9.2% of the total). This type of cancer tends to be a disease that occurs in more developed regions of the world (almost 55% of the cases are associated to those regions), contradicting the trend demonstrated by Table 1.1. (Ferlay et al., 2012)

This is a type of cancer that starts by affecting the tissues of colon or the rectum, (ACS, 2014) which are parts of the digestive system. As can be seen in Figure 1.2, the colon corresponds to the first and longest part of the large intestine, and the rectum constitutes the final and smallest part. (NCI, 2006) The colon is coated with mucous membranes, and also contains lymphoid cells that are a part of the body's immune defenses. (WCRF / AICR, 2007)

The function of this muscular tube is to absorb the fluids of the food that was previously processed by the stomach and the small intestine, and turn it into solid waste. Afterwards, the waste is transferred from the colon to the rectum, and then expelled through the anus. (NCI, 2006)

The etiology of colorectal cancer includes both genetic and environmental factors. Among them, only about 20% can be attributed to heritable gene variations, suggesting that the largest fraction of sporadic colorectal cancer cases is related to environmental causes. (Kim et al., 2013)

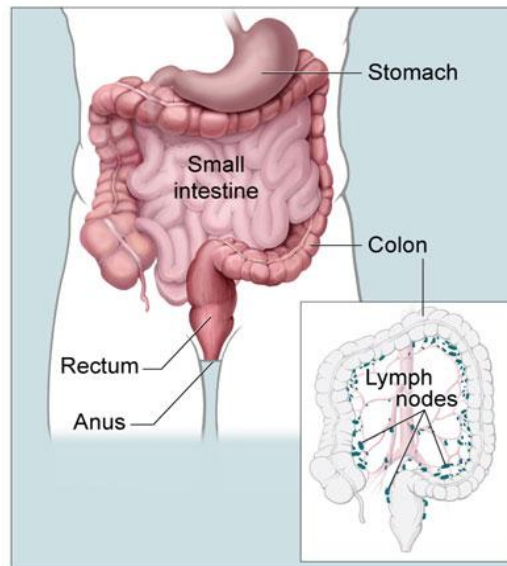

Figure 1.2 Schematic representation of part of the digestive system, including the colon and rectum. (NCI, 2006)

According to the Second Expert Report, published in 2007 by the American Institute for Cancer Research, among the environmental factors that are involved in the risk of contracting cancer, there is extensive evidence that nutritional factors can influence several fundamental processes which are related to cancer development and progression (see Figure 1.3). (WCRF / AICR, 2007) In particular, colorectal cancer is generally pointed to be greatly affected by food and nutrition factors, as well as other types of cancer that affect the gastrointestinal tract. (Boivin et al., 2009; Kaliora et al., 2014)

Several epidemiological and experimental studies have suggested that consumption of a typical Western-style diet, that is high in fat and protein, significantly increases colorectal cancer risk, whereas a high intake of fruits, vegetables, and whole grains is shown to be protective against this type of cancer. (Kim et al., 2013)

It is estimated that cancer is 30 to 40% preventable over time, by a convenient diet and regular physical activity. On a global scale this represents 3 to 4 million cases of cancer that can be prevented, every year. However, it is expected that, with the increasing prevalence of diseases like obesity, the colorectal cancer incidence increases as well. (WCRF / AICR, 2007)

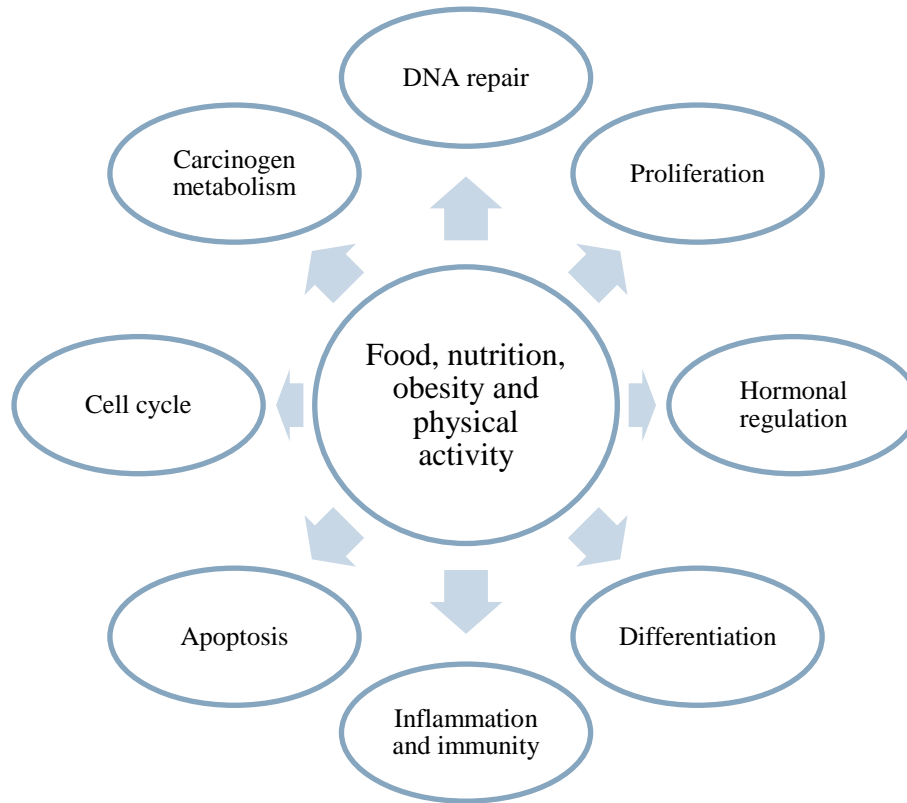

Figure 1.3 Fundamental processes in promotion or inhibition of cancer development and progression, which can be influenced by food, nutrition, obesity and physical activity. (Adapted from WCRF / AICR, 2007)

1.2. Herbs and Spices: Their Role in Cancer Prevention and Treatment

Plants and foods have been used for centuries for their medicinal properties, to prevent and treat all kind of diseases, including cancer. (Mehta et al., 2010) Fossil records date human use of plants for medical purposes at least to the Middle Paleolithic age, some 60000 years ago. (Fabricant et al., 2001) Hence, there is no doubt that herbs are the oldest drugs in the world. (Kaliora et al., 2014)

All species of plants produce a large number of organic compounds, which are imperative for their normal development and function. These chemicals include the primary metabolites suchlike amino acids, carbohydrates, fats, nucleic acids, etc.; and the secondary metabolites, which are specific to some taxonomic groups, such as terpenes, phenolics, carotenoids, alkaloids, saponins, glucosinolates, cyanogenic glycosides, etc. However this group of chemicals does not appear to participate directly in the development and growth of plants. Recent research shows that these so called secondary metabolites play an essential role in plants' protection against some environmental stresses. (Croteau et al., 2000; Krzyzanowska et al., 2010)

Nowadays, it is believed that the phytochemicals that compose these groups of secondary metabolites are, among other things, responsible for the health promoting effects shown by plants and foods over the centuries. (Patil et al., 2009) This belief is supported by studies that were conducted in the last decades, which show that these bioactive compounds have crucial roles in the prevention of chronic diseases, including cancer, diabetes and hypercholesteremia. (Mehta et al., 2010) Examples of these key compounds that are present in herbs and spices can be found in Table 1.2.

In fact, epidemiological, *in vitro*, *in vivo* and clinical trials that have been conducted over the years indicate that a plant-based diet, especially the consumption of fruit, vegetables and whole grain, can reduce the risk of chronic diseases, particularly cancer. These products are rich sources of particular classes of phytochemicals, and therefore are thought to have health promoting actions. (Rafter, 2002; Krzyzanowska et al., 2010) According to the U.S. National Cancer Institute, there are more than 30000 plants identified with phytochemicals possessing anticancer activity. (Kaliora et al., 2014)

It is known that some of these phytochemical compounds have the ability of targeting several key events that are involved in the development of cancer (see Figure 1.4), and act like chemopreventive agents. However, it is likely that this behavior arises from synergistic combinations between several distinct molecules, not only within a given food, but also from the overall composition of the diet. (Boivin et al., 2009)

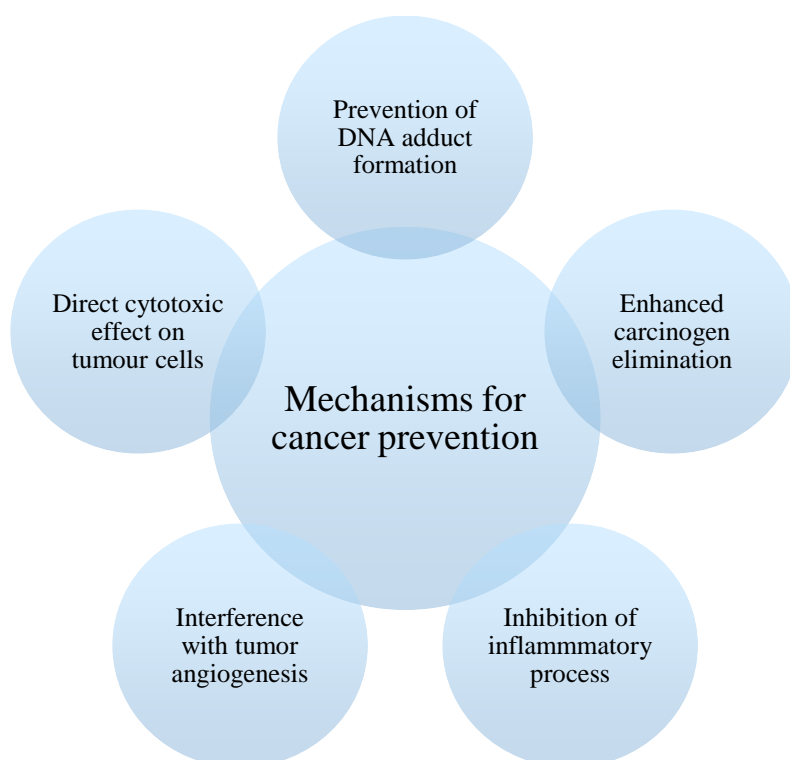

Figure 1.4 Potential mechanisms for cancer prevention with phytochemicals. (Adapted from Boivin et al., 2009)

Table 1.2 Examples of bioactive components in commonly used herbs and spices. (Adapted from Kaefer & Milner, 2008)

Herb/Spice	Bioactive Components
Allspice	Eugenol
Basil	Eugenol, apigenin, limonene, ursolic acid, methyl cinnamate, 1,8-cineole, α -terpinene, anthocyanins, β -sitosterol, carvacrol, cintronellol, farnesol, geraniol, kaempferol, menthol, p-coumaric acid, quercetin, rosmarinic acid, rutin, safrole, tannin, catechin
Cardamom	Limonene, caffeic acid
Caraway	Carvone, limonene, α -pinene, kaempferol
Cinnamon	Cinnamic aldehyde, 2- hydroxycinnamaldehyde, eugenol
Cloves	Eugenol, isoeugenol, gallic acid
Coriander	Quercetin, caffeic acid, cineole, geraniol, borneol, 1,8-cineole, α -terpinene, β -carotene, β -pinene, β -sitosterol, cinnamic acid, ferulic acid, γ -terpinene, kaempferol, limonene, myrcene, p-coumaric acid, p-cymene, quercetin, rutin, vanillic acid
Cumin	α -Pinene, β -pinene, γ -terpinene, p-cymene, cuminaldehyde, carvone, 1,8-cineole, β -carotene, β -sitosterol, caffeic acid, carvacrol, carveol, geraniol, kaempferol, limonene, p-coumaric acid, quercetin, tannin, thymol
Dill	Carvone, limonene, isorhamnetin, kaempferol, myricetin, quercetin, catechin
Fennel	α -Pinene, β -carotene, limonene, quercetin, benzoic acid, β -sitosterol, caffeic acid, cinnamic acid, ferulic acid, fumaric acid, kaempferol, myristicin, 1,8-cineole, p-coumaric acid, quercetin, rutin, vanillic acid, vanillin
Garlic	Allicin, diallyl disulfide, allyl isothiocyanate
Ginger	Zingiberone, zingiberene, ingerol, paradol, curcumin, shagoal
Lavender	Camphor, 1,8-cineole, borneol
Lemongrass	Farnesol, geraniol
Licorice	Glycyrrhizin
Marjoram	Eugenol, limonene, ursolic acid, 1,8-cineole, α -pinene, α -terpinene, carvacrol, farnesol, geraniol, p-cymene, rosmarinic acid, sterols, thymol, apigenin
Mustard	Allyl isothiocyanate, β -carotene
Nutmeg	Caffeic acid, catechin
Onion	Quercetin, dipropyl disulfides
Oregano	Apigenin, luteolin, myricetin, quercetin, caffeic acid, p-coumaric acid, rosmarinic acid, carvacrol, thymol
Pennyroyal	Pulegone, menthone, menthol, apigenin, luteolin-7-O- β -glucoside, isoquercetin,
Paprika	α -Tocopherol, capsaicin, dihydrocapsaicin, lutein, β -carotene, ascorbic acid, vitamin E
Parsley	Apigenin, luteolin, kaempferol, myricetin, quercetin, caffeic acid
Pepper, black	Piperidine, piperine, limonene, α -pinene, β - pinene
Pepper, red (also known as chili or cayenne pepper)	Capsaicin, α -tocopherol, lutein, β -carotene, ascorbic acid, vitamin E

Table 1.2 (Continued).

Herb/Spice	Bioactive Components
Peppermint	Limonene, menthol, eriodictyol, hesperitin, apigenin, luteolin
Rosemary	Carnasol, carnosic acid, cineole, geraniol, α -pinene, β -carotene, apigenin, limonene, naringin, luteolin, caffeic acid, rosmarinic acid, rosmanol, vanillic acid
Saffron	Croctin, crocin, β -carotene, safranal, all trans retinoic acid
Sage	α -pinene, β -sitosterol, citral, farnesol, ferulic acid, gallic acid, geraniol, limonene, cineole, perillyl alcohol, β -carotene, catechin, apigenin, luteolin, saponin, ursolic acid, rosmarinic acid, carnosic acid, vanillic acid, caffeic acid, thymol, eugenol
Spearmint	Carvone, limonene, 1,8-cineole, perillyl alcohol, catechin, epicatechin, rutin, myrecitin, luteolin, apigenin and naringenin
Tarragon	Luteolin, isorhamnetin, kaempferol, quercetin, caffeic acid
Tea, green	(-)-Epigallocatechin gallate, (-)-epigallocatechin, (-)-(+)-catechin, theophylline, gallic acid, theanine
Thyme	Thymol, carvacrol, cineole, α -pinene; apigenin, β -carotene, eugenol, limonene, ursolic acid, luteolin, gallic acid, caffeic acid, rosmarinic acid, carnosic acid, hispidulin, cismartin
Turmeric	Curcumin, curcuminoids

1.2.1. Phytochemicals and their health-promoting effects

Currently, the therapeutic drugs used on the treatment of cancer are mainly cytotoxic. They act, directly or indirectly, by killing cancer cells. (Gould, 1997) Thence, in the last years, there has been a growing interest in exploring natural bioactive phytochemical substances, to be used in prevention and treatment of cancer. (Gotti, 2011)

It is believed that fruits, vegetables, herbs and spices have some compounds on their constitution, whose properties are effective against a wide variety of cancers. This anticancer power arises essentially from their high content of phytochemicals. (Boivin et al., 2009)

Naturally occurring phytochemicals are bioactive nonnutrient compounds of various plant parts, such as seeds, fruits, leaves and rhizomes. (Kumazaki et al., 2013)

According to Harborne (1999), there are three major classes of plant chemicals: terpenoids, alkaloids and other nitrogen-containing plant constituents and phenolic metabolites. The phytochemicals included in these major classes are summarized in Table 1.3.

Phytochemicals that are present in the diet, are commonly associated to health benefits, including glucosinolates, terpenoids (carotenoids, monoterpenes and phytosterols), and various groups of polyphenols (anthocyanins, flavones, etc.). (Espín et al., 2007) Over the years, extensive research has demonstrated that, in fact, many of these natural phytochemicals, derived from both dietary sources and medicinal plants, have health-beneficial effects in the prevention and treatment of several human clinical conditions. (Neergheen et al., 2010; Ziech et al, 2012)

Table 1.3 Major classes of plant chemicals and their subclasses. (Adapted from Harborne, 1999)

Terpenoids	Alkaloids and Other Nitrogen-Containing Metabolites	Phenolic Metabolites
Monoterpenoids	Amaryllidaceae	Anthocyanins
Iridoids	Betalain	Anthochlors
Sesquiterpenoids	Diterpenoid	Benzofurans
Sesquiterpene lactones	Indole	Chromones
Diterpenoids	Isoquinoline	Coumarins
Triterpenoid saponins	Lycopodium	Minor flavonoids
Steroid saponins	Monoterpene	Flavonones and flavonols
Cardenolides and bufadienolides	Sesquiterpene	Isoflavonoids
Phytosterols	Peptide	Lignans
Cucurbitacins	Pyrrolidine and piperidine	Phenols and phenolic acids
Nortriterpenoids	Pyrrolizidine	Phenolic ketones
Other triterpenoids	Quinoline	Phenylpropanoids
Carotenoids	Quinolizidine	Quinonoids
	Steroidal	Stilbenoids
	Tropane Compounds	Tannins
	Nonprotein amino acids	Xanthones
	Amines	
	Cyanogenic glycosides	
	Glucosinolates	
	Purines and Pyrimidines	

In the last few years, the biggest impact of plant-derived drugs, was probably felt in the antitumor area, and nowadays, a few plant products are already being used to treat cancer. Drugs like taxol, vinblastine, vincristine and camptothecin have greatly improved the effectiveness of chemotherapy against some of the deadliest cancers. (Raskin et al., 2002)

Since current clinical therapies, including conventional chemotherapy, radiation, immunosuppression and surgery, are limited and are associated to a high number of undesired side effects, there is a grave need for additional and innovative treatment options. (Neergheen et al., 2010) Natural therapies, such as the use of plant-derived products in cancer treatment, may reduce the referred adverse side effects. (Desai et al., 2008)

Chemoprevention involves the use of pharmacological, dietary bioactive compounds, phytochemicals and even whole plant extracts to prevent arrest or reverse the cellular and molecular processes of carcinogenesis. In addition, epidemiological and experimental studies show that these phytochemicals have not only a protective role, but also a power to contain and control carcinogenesis. (Neergheen et al., 2010)

For the past decades, there has been a growth of interest in chemoprevention of colorectal, breast, and prostate cancer. The use of chemopreventive agents arising from natural sources appears to be particularly appropriate for colorectal tumors. (Kim et al., 2003)

1.2.1.1. Terpenes

Plant living species contain a large diversity of bioactive compounds. In particular, medicinal plants are known for being rich in terpenes (for instance carvacrol, citral, linalool and geraniol) and phenolic compounds (like flavonoids and phenolic acids). (Ortega-Ramirez, 2014)

The terpenes are characterized by being derived from repetitive combinations of branched five-carbon units (C₅) based on isoprene skeleton. (Croteau et al., 2000) In plants, their function is to fix carbon through photosynthetic reactions, using photosensitizing pigments. (Dillard & German, 2000)

Terpenes have a unique antioxidant activity: they react with free radicals by taking advantage of their long carbon side chain and separate themselves to form fatty membranes. (Dillard & German, 2000)

Depending on the number of isoprene units, the terpenes form structurally and functionally different classes. These classes are outlined in Figure 1.5, along with some specific examples for each of them. (Croteau et al., 2000; Bakkali et al., 2008)

The herbal terpenoids have been proved to have strong anticancer potential by inhibition of tumor proliferation and induction of apoptosis. Such compounds are inversely related with the risk of cancer including breast, prostate, and liver cancer. (Yang et al., 2014) In particular, a number of dietary monoterpenes, which are nonnutritive components, are known for having antitumor activity. They exhibit not only the ability to prevent the formation and progression of cancer, but also to regress preexisting malignant tumors. (Crowell, 1999)

Monoterpenes are naturally occurring hydrocarbons that consist of two isoprene units (Gould, 1997) and are undoubtedly the major compounds present in essential oils, representing 90% of their constitution (Sánchez-González et al., 2011) and corresponding to 5% of the plant dry weight (Croteau et al., 2000). Monoterpenes are the major responsible for the distinctive fragrance of many plants. (Crowell, 1999) Having a great variety of structures, they can occur in acyclic, monocyclic and bicyclic forms, comprising several functions, which are summarized in Table 1.4. (Gould, 1995; Bakkali et al., 2008) They can be found in lots of commonly consumed fruits, vegetables, herbs and spices, including citrus fruits and food flavoring such as mints. (Gould, 1995)

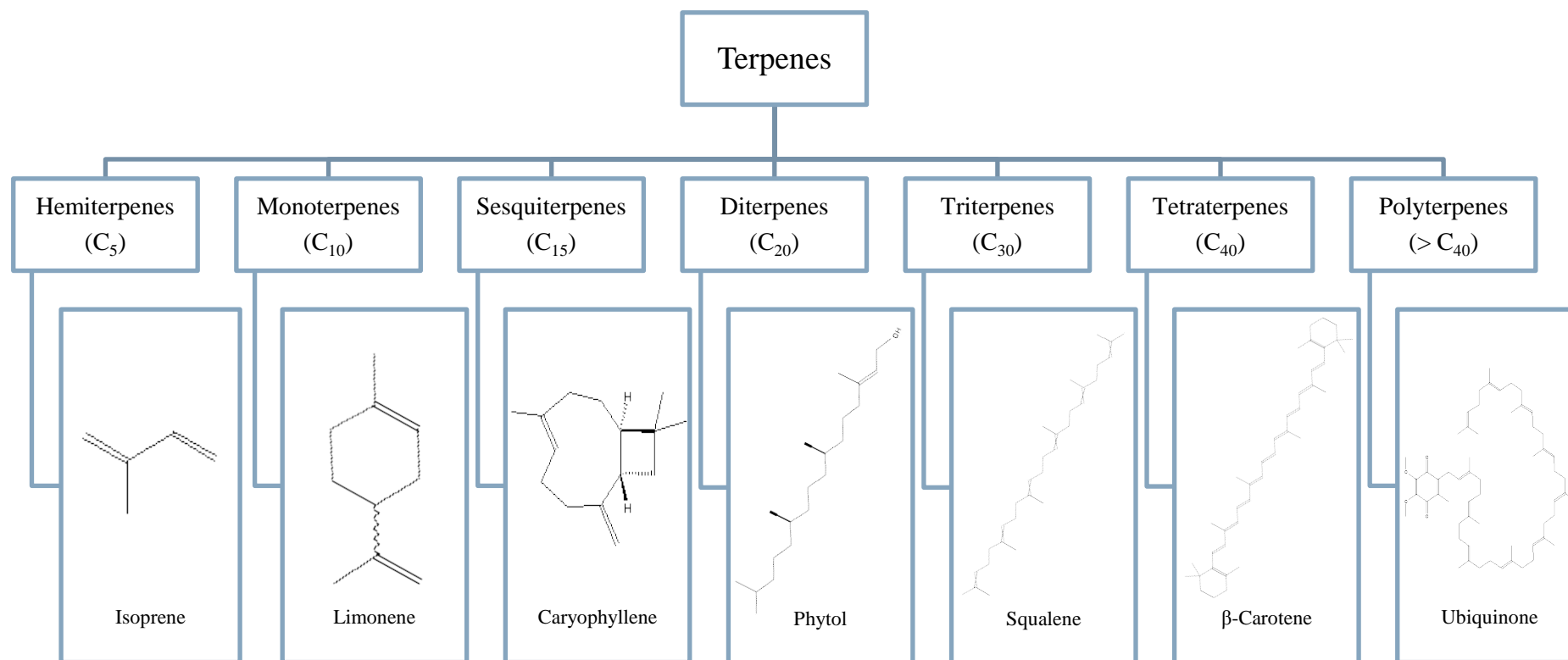

Figure 1.5 Different classes of terpenes. (Adapted from Bakkali et al., 2008)

Table 1.4 Multiple structures of monoterpenes. (Adapted from Bakkali et al., 2008)

	Acyclic	Monocyclic	Bicyclic
Carbides	Myrcene Ocimene	Limonene Terpinenes p-Cimene Phellandrenes	Pinenes -3-Carene Camphene Sabinene
Alcohols	Geraniol Linalool Citronellol Lavandulol Nerol	Menthol α -terpineol Carveol	Borneol Fenchol Chrysanthenol Thuyan-3-ol
Aldehydes	Geranial Neral Citronellal		
Ketones	Tegetone	Menthones Carvone Pulegone Piperitone	Camphor Fenchone Thuyone Ombellulone Pinocamphone Pinocarvone
Esters	Linalyl acetate Citronellyl acetate	Menthyl α -Terpinyl acetate	Isobornyl acetate
Ethers		1,8-cineole	Menthofurane
Peroxydes			Ascaridole
Phenols		Thymol Carvacrol	

Monoterpenes of plant origin have shown potential to inhibit proliferation of numerous types of organ-specific cancer cells. (Gould, 1995; Burke et al., 1997; Bardon et al., 2002) Terpenoids, such as D-limonene (Crowell, 1999), perillyl alcohol (Crowell, 1999; Bardon et al., 2002; Sundin et al., 2010), menthone, (R)-(+)-citronellal, (S)-(-)- β -citronellol, α -terpinene, terpinolene, (-)- β -pinene (Yoshida, et al., 2008), farnesol, geraniol (Sundin et al., 2010), α -terpineol, linalyl acetate, camphor (Hassan et al., 2010), carvacrol, thymol, carveol, carvone, eugenol, isopulegol (Jaafari et al., 2012) menthol (Tatman & Mo, 2002), among others are known to inhibit proliferation of cancer cells. Plus, plant volatile oils that are rich in β -myrcene, (+)-sabinene, α -farnesene, β -bisabolene, triacontane, 1,8-cineol, borneol, among others, were demonstrated to inhibit proliferation of breast, colon and other cancer cells. (Shehzad et al., 2010; Jayaprakasha et al., 2013)

Since monoterpenes are non-toxic compounds with lipophilic characteristics, they have the ability to pass through the cell wall and the cytoplasmic membrane, disrupting the structure of their layers of polysaccharides, fatty acids and phospholipids and permeabilize them. In fact, cytotoxicity does appear to include such membrane damage. (Bakkali et al., 2008)

As an example, pulegone, which is a component of essential oils from mint species, can induce carcinogenesis through metabolism, generating the glutathione depletory *p*-cresol (Zhou et al., 2004).

1.2.1.2. Fatty acids

The beneficial role of some fatty acids in chronic diseases, such as atherosclerosis or rheumatoid arthritis, has been known for years. (Sahena et al., 2009)

Fatty acids are carboxylic acids with a variable unbranched aliphatic chain. (Bernal et al., 2011) This hydrocarbon chain length may vary from 8 to 30 carbons. (Sahena et al., 2009) and can be chemically classified as saturated or unsaturated (monounsaturated and polyunsaturated). It is known that their structure affects their nutritional and health effects. (Ricchi et al., 2009)

In acids with only a few carbons, the acid functional group dominates and gives the whole molecule a polar character. However, in fatty acids, the non-polar hydrocarbon chain gives the molecule a non-polar character. (Sahena et al., 2009)

Fatty acids play multiple roles in humans and other organisms. They are important energy substrates and represent a substantial part of lipids, one of the three major components of biological matter (along with proteins and carbohydrates). (Tvrzicka et al., 2011)

It has been proved that they are important as nutritional substances in living organisms (Bernal et al., 2011), and that the presence of saturated and unsaturated fatty acids on human diet has implications on health. It is believed that an excessive consumption of saturated fatty acids increases the risk of vascular disease, whereas the consumption of unsaturated fatty acid is believed to be beneficial, decreasing the risk of cardiovascular diseases. (Botelho et al., 2014) The most abundant fatty acids present in the diet are palmitic acid, which is a saturated fatty acid, and oleic acid, a monounsaturated fatty acid. (Ricchi et al., 2009) Their structures are represented in Figure 1.6, along with some other fatty acids.

There have been many clinical and epidemiologic studies concerning dietary fatty acids and their relation with risks of many chronic diseases. Some fatty acids are considered to be effective in reducing the incidence of cancer, cardiovascular diseases, inflammation, autoimmune disorders, hypertension, hypotriglyceridemic effect, etc.. (Hayashi et al., 1992; Tavakoli et al., 2012)

Several natural matrices contain in their composition fatty acids, such as, vegetable oils from plants, seeds, fruits, nuts and soybeans, rice oil, aquatic animals (salmon, catfish, crustacean), and alga. (Bernal et al., 2011)

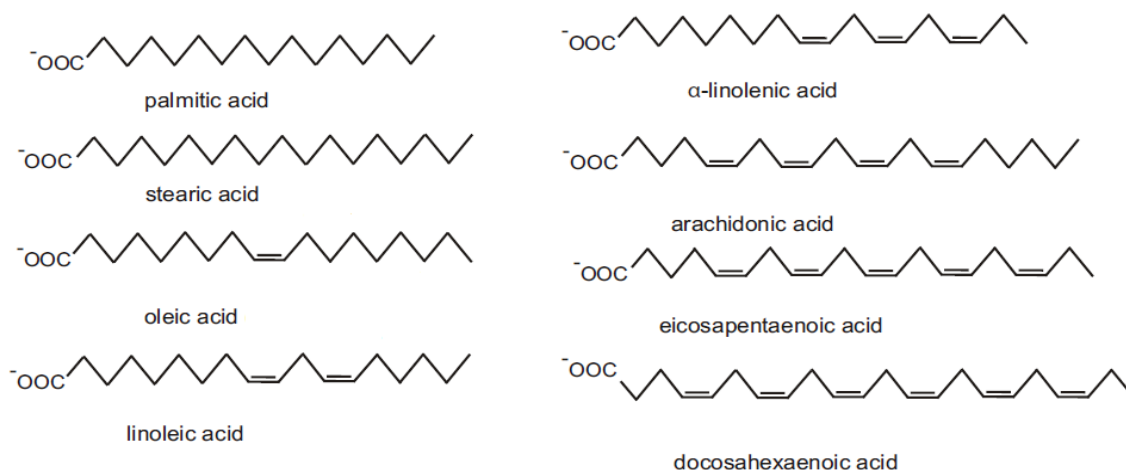

Figure 1.6 Structural formulas of some fatty acids. (Adapted from Tvrzicka et al., 2011)

1.3. *Lavandula* and *Mentha* Species

1.3.1. *Lavandula* spp.

The genus *Lavandula*, commonly known as lavender, is an important member of the *Lamiaceae* family. Lavenders are low-growing bushy shrubs (Combest, 2002), and many species are cultivated around the world, mainly in the Mediterranean region. Over 200 species are reported to exist. (Giray et al., 2008; Fisser & Pilkington, 2012)

It is possible to trace document evidence, for the use of those flowering plants as therapeutic agents, back to the ancient Romans and Greeks. (Cavanagh & Wilkinson, 2002)

Currently, due to its unique chemical composition, both the plant material and its essential oil have a commercial interest in a wide range of industries, such as cosmetic, perfumery, aromatherapy and pharmaceutical industries for its therapeutic effects. (Giray et al., 2008; Danh et al., 2012; Gonçalves et al., 2013) Recently it has also been employed in food industry as natural flavoring for beverages, ice cream, candy, baked goods and chewing gum. (Da Porto et al., 2009)

The medicinal importance of the plants of this genus is well documented and the drugs prepared from it are registered in many Pharmacopeia. (Giray et al., 2008)

Traditionally, and depending on the species type, lavender plants are reported to be effective as a sedative, expectorant, carminative, anticonvulsant, anti-inflammatory, antispasmodic, analgesic, antiseptic, antiviral, antibacterial, etc. (Giray et al., 2008; Danh et al., 2012; Vakili et al., 2014)

Many other clinical benefits are claimed for lavender plants use, namely on the central nervous system, including relief of stress and mild anxiety, nervous headache and depression symptoms, positive emotional states as improving mood, and relaxation. (Giray et al., 2008; Hritcu et al., 2012; Gonçalves et al., 2013; Raisi Dehkordi et al., 2014)

One of the most important properties of lavender essential oil is its antioxidant activity. It is applied in food processing not only as a flavoring ingredient but also as an antioxidant, to protect food products. (Danh et al., 2012)

The various lavenders have similar ethnobotanical properties and major chemical constituents; however, there are some differences in the reported therapeutic uses for different species. (Fisner & Pilkington, 2012)

The chemical composition of lavender is complex and is comprised of more than a hundred constituents, being linalool, linalyl acetate, camphor, 1,8-cineole and 4-terpineol the predominant in essential oils. These constituents, which are responsible for its pharmacological activity, can vary significantly in different extracts. (Hritcu et al., 2012; Vakili et al., 2014)

Species like *Lavandula angustifolia* and *Lavandula stoechas* grow in Portugal: *Lavandula angustifolia*, commonly known as English lavender, is a stockier plant with a fuller flower, and *Lavandula stoechas*, which is commonly called French lavender, is recognized for its short stems with fat purple bracts on the top. (Platt, 2009).

Although there are controversial opinions and inconclusive data about this genus health-promoting power, there are studies that support some of its biological activities. Certainly, these are plants with attractive but still unexplored potential.

1.3.2. *Mentha* spp.

Mentha is also a genus of *Lamiaceae* family (the same of *Lavandula* spp.), and includes 25 to 30 species (Damien Dorman et al., 2003) that can be found all over the world, namely in Europe, Africa, Asia Australia and North America. (Kedia et al., 2014)

Lamiaceae species are considered to be very important because of their use in folk medicine, culinary, cosmetics, perfumery, flavoring and production of essential oils throughout the world. (Aghel et al., 2004; Riahi et al., 2013)

The *Mentha* genus is the most important in the *Lamiaceae* family because it contains several plants with essential oils which have high economic value. (Chen et al., 2012)

According to Lawrence (2007) these are the most economically important essential oils produced, since their annual production exceeds 23.000 metric tones corresponding to a value of more than 400 millions of dollars.

Mentha oils are essentially used in the cosmetics, pharmaceuticals, confectionery food, and liquor industries, and mint corps are cultivated all around the world precisely for its high valuable oils. (Khanuja et al., 2000)

The plants from *Mentha* genus are used by humans for over 2000 years. (Ansari et al., 2010) Nowadays, it is known that some health benefits are related to these plants. Aerial parts from *Mentha* species have been widely used for herbal teas and condiments, as spasmolytics, antibacterial agents and for their analgesic and antigenotoxic properties. (Damien Dorman et al.,

2003) There are also records of their use as part of the treatment of cold, cholera, bronchitis, tuberculosis and sinusitis. *Mentha* also possesses diuretic, carminative, antifatulent, expectorant and antitussive properties. (Riahi et al., 2013) Therapeutically, mint is considered to be a source of micro and macro-elements and vitamins. (Rubio et al., 2012)

Mentha plants have been confirmed to possess antimicrobial, antioxidant, antifungal, antiulcer, anti-inflammatory, anti-mutagenic, antispasmodic and stimulant properties. Significant effects on cholesterol, on blood and immunity parameters, and on triglyceride values have also been noted. Additionally, its antidote properties for poisons have been reported as well. (Talpur, 2014)

Since *Mentha* plants are a rich source of polyphenols, this genus possesses a powerful antioxidant activity. As an example, this property allows the prevention of food oxidation; therefore, this *Mentha* property has a special interest to the food industry (Ansari et al., 2010), where they are used as natural preservatives. (Curutchet et al., 2014) Recently, interest in finding naturally occurring antioxidants to replace synthetic antioxidants has considerably increased, since synthetic antioxidants are restricted, due to their side effects such as carcinogenesis. (Riahi et al., 2013)

Some of the most economically important species of this genus are *Mentha aquatica*, *Mentha canadensis*, *Mentha spicata*, *Mentha pulegium* and their hybrids *Mentha x gracilis*, *Mentha x piperita* and *Mentha x villosa-nervata*. (Ansari et al., 2010; Curutchet et al., 2014)

Some species of *Mentha*, as *Mentha spicata*, *Mentha x piperita* and *Mentha pulegium* grow in Portugal.

Mentha spicata, commonly known as spearmint, is a hybrid resulting from *Mentha longifolia* and *Mentha rotundifolia* and is the *Mentha* plant that is used more frequently. (Ansari et al., 2010) Spearmint is an aromatic plant (Telci et al., 2010) that is widely used in culinary as a flavor enhancer. Its flavor is essentially related to carvone, dihydrocarvone, carveol, dihydrocarveol and limonene, which are substances that are present in this plant chemical composition. (Curutchet et al., 2014) Spearmint is known for its antifungal effect against some food-poisoning fungi and other storage insects (Kedia et al., 2014).

Mentha x piperita, also known as peppermint, is one of the most widely consumed single ingredient herbal teas, or tisanes. Peppermint characteristic flavour is related to its main component, menthol, and its isomers (isomenthol, neomenthol, and neoisomenthol), menthone, menthyl esters and piperitone. (Curutchet et al., 2014) This plant is one of the world's oldest medicinal herbs, and is used in both Eastern and Western traditions. It is also reported that peppermint contains polyphenolic compounds, and consequently possesses strong antioxidant properties. (Nanekarani et al., 2012) *Mentha x piperita* var. *citrata* (Ehrh.) Briq., is a *Mentha x piperita* variety and is erroneously nominated *Mentha citrata*. This species produces a type of essential oil which contains 84 to 90% linalool and linalyl acetate, characteristic acyclic

components, in contrast to other species of the genus *Mentha* which contain menthol, menthone, carvone, limonene and pulegone as majoritary cyclic components. (Garlet et al., 2013)

Both spearmint and peppermint are popular flavors used in a wide variety of sugar confectioneries, chewing gums, toothpastes, chocolate fillings, pharmaceuticals, and liqueurs. (Barton et al., 1992)

Mentha pulegium, which is commonly known as pennyroyal, is reported as having antimicrobial actions in vitro, among others. (Erhan et al., 2012) The essential oils composition depends on the genetic structure, the climatic factors and the agronomical practices applied on the plants. (Telci et al., 2010) However, its major oil components usually are pulegone, piperitone and isomenthone/neoisomenthol. (Mahboubi & Haghi, 2008) This essential oils and dry parts of the plant have been traditionally used in medicine. (Teixeira et al., 2012)

1.4. Natural Health Products and Nutraceuticals

Long before the development of nutritional sciences, the relationship between food and health was already accepted. Hippocrates (460 - 370 BC), a Greek physician referred to as the father of western medicine, stated “let food be your medicine and medicine be your food”. (Bernal et al., 2011)

The knowledge that some natural products have health-giving and curative function is ancient. However, the real studies about the relation between medicine and diet only began recently, with epidemiological and clinical studies, which have unraveled some chemical and physiological mechanisms of the effects of natural bioactive compounds on human health, hence proving the importance of dietary factors on health status. (Shahidi, 2009)

Nowadays, scientists continue to look into nature, in order to transform some compounds that are present in those products, into powerful drugs, that can be used with positive impact on the human body. (Goldberg, 1994)

The term “nutraceutical” was firstly coined and defined by the Foundation for Innovation in Medicine in 1989. (Andlauer and Fu, 2002) This word was created to describe the union between nutrition and pharmaceuticals, since there was a need to provide a name for the union of those two areas of research. Thus, a nutraceutical can be defined as any substance that can be considered a food or part of a food that provides recognized medical or health benefits, including the prevention and treatment of disease, in dosages that exceed those that could be obtained from normal foods. (Andlauer and Fu, 2002; Bernal et al., 2011) These commodities can assume the form of pills, powders, capsules, vials, etc., containing food bioactive compounds as active principles. (Espín et al., 2007)

Natural products have particular interest as chemopreventive agents because of their commonly low toxicity profiles and potential effectiveness. The U.S. National Center for

Complementary and Alternative Medicine defines natural products as dietary supplements and include vitamins, minerals, probiotics, and herbal medicines. (Greenlee, 2012)

1.4.1. Extraction of Bioactive Compounds

In the past two decades, the interest in the search for bioactive compounds from natural origin has increased. This growth was due to the proven capacity of some of them against several diseases. (Herrero et al., 2013)

In recent years, different sources of bioactive compounds have been studied, such as plants, food by-products and marine products. (Herrero et al., 2006) In regard to plants, the bioactive compounds are commonly produced as secondary metabolites. In some species, those metabolites have demonstrated pharmacological or toxicological effects in humans and animals. (Azmir et al., 2013)

Plant extracts, containing these interesting compounds, are widely used in the food, pharmaceutical and cosmetics industries. (Wang & Weller, 2006) These extracts can be obtained by conventional or non-conventional extraction methods. (Azmir et al., 2013)

Conventional techniques, such as Soxhlet extraction have serious drawbacks: require long extraction times; use large amounts of toxic organic solvents that needs to be evaporated/concentrated later and it is possible that the targeted compounds undergo thermal decomposition since the extraction usually occurs at the boiling point of the solvent during a long time. (Wang & Weller, 2006; Araus et al., 2009) Plus, there are few parameters that can be adjusted to control the extraction selectivity. (Lang & Wai, 2001)

Nowadays, the safety of both producers and consumers is a major requirement of any new product or process. As a consequence, the mandatory regulations on the usage of hazardous, carcinogenic, or toxic solvents, as well as high energy costs for solvent regeneration, have forced the natural extract industries to adopt new methodologies. (Mukhopadhyay, 2000)

Since pharmacologically active compounds in plants are usually in low concentrations and the final products must be safe for the consumers, lots of research has been done in order to develop more effective, selective and clean extraction techniques to recover these phytochemicals from the raw materials. (Lang & Wai, 2001)

With regard to product quality, supercritical fluid extraction has emerged over the last years as an alternative to the traditional extraction methods. (Pourmortazavi & Hajimirsadeghi, 2007)

1.4.1.1. Supercritical Fluids

Supercritical fluid extraction (SFE) is a particularly interesting technology that is innovative, clean and environmental friendly, with special interest for the extraction of plant and herb products. (Fornari et al., 2012) It uses clean, safe, inexpensive, nonflammable, nontoxic,

environment-friendly, nonpolluting solvents, such as carbon dioxide (CO₂), in supercritical conditions. (Mukhopadhyay, 2000)

As demonstrated in Figure 1.7, the state of a pure component is named supercritical fluid (SCF) when both temperature and pressure are forced beyond its critical point (CP). The value of that specific temperature is called critical temperature (T_c) and the corresponding vapor pressure is named critical pressure (P_c). When these conditions are achieved, the fluid assumes the properties of both gas and liquid. (Mukhopadhyay, 2000; Herrero et al., 2006)

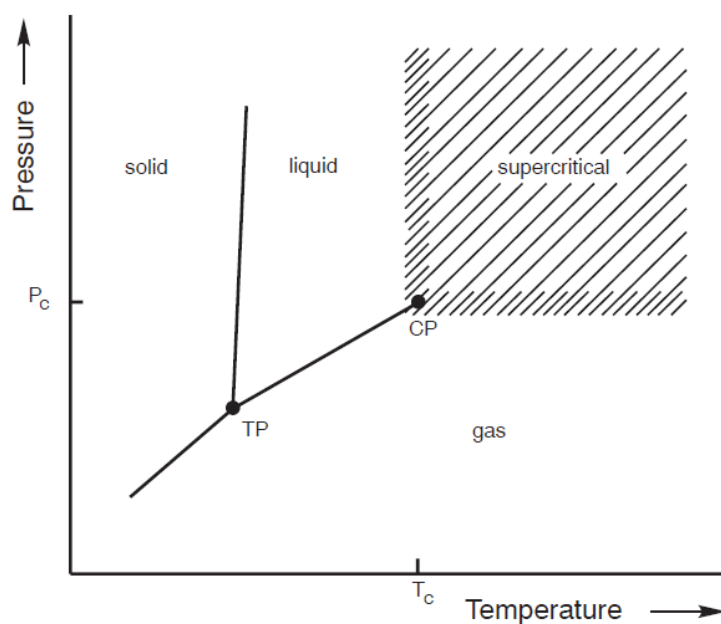

Figure 1.7 Pressure-temperature diagram for a pure component. (Mukhopadhyay, 2000) Legend: CP – critical point; P_c – critical pressure; T_c – critical temperature; TP – triple point.

A correlation between the values of some of the physical properties of gases, liquids and supercritical fluids is shown in Table 1.5.

The values expressed in Table 1.5 suggest that the density of supercritical fluids is similar to the density values of liquids which imply an identical solvating power. On the other hand, the values of viscosity are similar to the values presented by gases. Further, its diffusivity is intermediate between the two states.

The supercritical state represents the region where the maximum solvent capacity and the largest variations in solvent properties can be achieved with slight modifications in temperature and pressure values. (Mukhopadhyay, 2000)

Table 1.5 Range values of some physical properties of gases, liquids and supercritical fluids. (adapted from Herrero et al., 2006)

State of the Fluid	Density (g/cm ³)	Diffusivity (cm ² /s)	Viscosity (g.s/cm)
Gases P = 1atm; T = 21°C	10 ⁻³	10 ⁻¹	10 ⁻⁴
Liquids P = 1atm; T = 15 – 30°C	1	< 10 ⁻⁵	10 ⁻²
Supercritical Fluids P = P _c ; T = T _c	0.3 – 0.8	10 ⁻³ – 10 ⁻⁴	10 ⁻⁴ – 10 ⁻³

1.4.1.2. Supercritical Fluid Extraction: Process and Operating Conditions

To successfully optimize an extraction of bioactive compounds by SFE, there are several important factors that must be studied and chosen prior to the experiments. Those factors are the type and pretreatment of sample, including the moisture of the samples and the particle size, the choice of the fluid and eventual modifiers and the extraction conditions, such as the temperature, pressure, flow rate and extraction time. (Lang & Wai, 2001; Wang & Weller, 2006)

The most relevant process parameter is perhaps the extraction pressure, since it can be used to adjust the selectivity of the SFE. Usually, the higher is the pressure, the larger is the solvent power and the smaller is the extraction selectivity. (Reverchon & De Marco, 2006)

There are several compounds that can be used as solvents in this kind of extraction. However, carbon dioxide is the most widely used by far. (Sihvonen & Hietaniemi, 1999) CO₂ is an inert, inexpensive, easily available, odorless, tasteless, environmentally friendly and safe solvent and, since it is a gas at ambient temperature and pressure, leaves no residue in the extract, being easily removed from it. (Mukhopadhyay, 2000)

The critical temperature of CO₂ is 33°C and its critical pressure is 74 bar. The moderate critical temperature makes it an ideal solvent for extracting thermolabile natural compounds, avoiding their degradation. (Fornari et al., 2012) Still, by increasing the temperature, the density of supercritical CO₂ (for a fixed pressure) can be reduced, thus reducing the solvent power of the supercritical solvent. However, when the temperature is increased, the vapor pressure of the compounds to be extracted increases as well. Thus, the tendency of these compounds to pass in the fluid phase also increases. (Reverchon & De Marco, 2006)

Supercritical CO₂ is also a suitable solvent to extract lipophilic compounds, due to its nonpolar character, such as the compounds that are present in plant essential oils. (Fornari et al., 2012) The solubility of some natural compounds in supercritical CO₂ is expressed in Table 1.6.

Therefore, to extract certain products that present some polarity is necessary to add polar co-solvents, also known as modifiers, to increase the solubility of the polar compounds.

Table 1.6 Solubility of natural compounds in supercritical CO₂. (Adapted from King & Bott, 1993)

	Very soluble	Moderately soluble	Almost insoluble
	Non-polar and slightly polar organic compounds of low molecular weight (< 250)	Organic compounds with higher molecular weight (~ 400) or higher polarity	Sugars, proteins
Examples	Monoterpenes and sesquiterpenes	Substituted terpenes and sesquiterpenes	Tannins, waxes and inorganic salts
	Thiols, pyrazines and thiazoles	Water	Chlorophyll, carotenoids, citric acid and malic acid
	Acetic acid, benzaldehyde, hexanol, glycerol, acetates	Oleic Acid, glycerol, decanol and saturated lipids (up to C12)	Glycine, nitrates and components in pesticides and insecticides

To extract nutraceuticals such as phenolics, alkaloids and glycosidic compounds, that are poorly soluble in CO₂, it is vital to add a small quantity of another solvent suchlike methanol, ethanol, acetonitrile, acetone, water, ethyl ether and dichloromethane, or even a mixture of solvents, to enhance their solubility, making them extractable. The most suitable solvent to extract nutraceuticals is ethanol, mostly because of its low toxicity. (Wang & Weller, 2006)

A supercritical fluid extraction system is shown in Figure 1.8. Briefly, the plant raw material is loaded in an extraction vessel, which is equipped with temperature and pressure controllers. The preheated fluid is pumped into the extraction vessel by a pump and then the fluid and the dissolved compounds are transported to separators. The product is then collected in the separators, where the solvation power of the fluid decreases by decreasing the pressure or increasing the temperature of the fluid. (Wang & Weller, 2006)

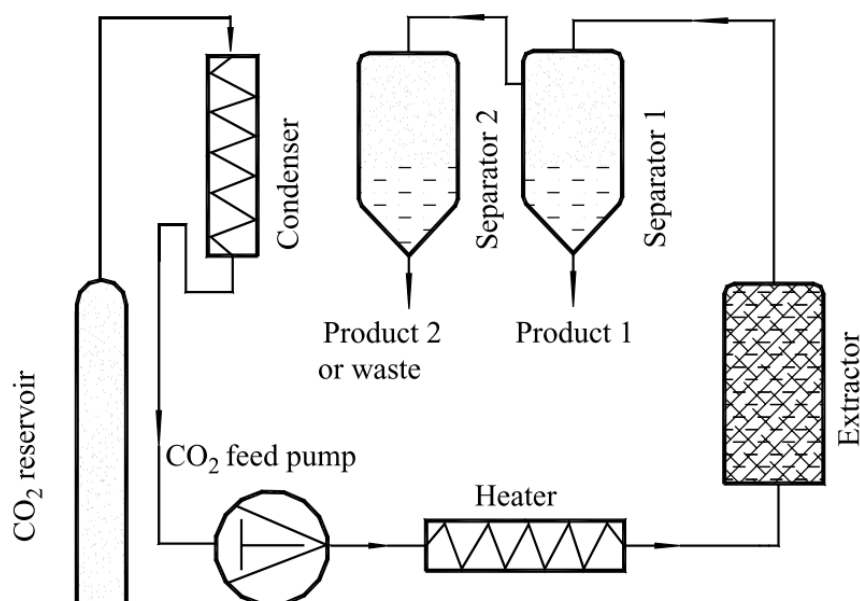

Figure 1.8 Schematic diagram of a basic supercritical fluid extraction system. (Adapted from Wang & Weller, 2006)

1.4.1.3. Main Advantages and Disadvantages of SFE

Since supercritical fluid extraction with carbon dioxide leaves no chemical residue, this technology is considered as an environment friendly separation process (Shilpi et al., 2013) and, when compared to traditional extraction methods that use toxic organic solvents, such as hexane, petroleum ether, chloroform, etc., presents several advantages. (Santana et al., 2012)

These fluids have numerous benefits thanks to their gas and liquid-like properties. They present higher diffusion coefficient and lower viscosity than liquids, which helps to a more favorable mass transfer. They are also absent of surface tension, which allows a rapid penetration into the pores of solid matrices, enhancing the extraction efficiencies. (Shilpi et al., 2013)

With these properties, the extraction conditions may be manipulated by slight variations of temperature and pressure which immediately affects the solubility of the various components of the matrix in the supercritical fluid. (Shilpi et al., 2013)

The general agreement is that supercritical extracts proved to be of superior quality, presenting better functional activity, when compared with extracts produced by hydro-distillation or using organic solvents, due to its selectivity. (Fornari et al., 2012)

When compared with conventional atmospheric pressure extraction techniques, the major disadvantage of SFE is related to the elevated investment costs. Yet, the base process scheme is relatively cheap and easily scaled up. (Reverchon & De Marco, 2006)

1.4.1.4. Applications of SFE

Since the 1970s, supercritical fluid extraction has been used to isolate natural products. (Sihvonen & Hietaniemi, 1999) This technology was extensively used in the past to extract target compounds from a variety of matrices. There are a number of examples where SFE has been scaled up, such as decaffeination of coffee and tea, refining of cooking oils and extraction of flavors and pungencies from plants. (Mukhopadhyay, 2000; Wijngaard et al., 2012) Nonetheless, considering the high investment costs, SFE technology is mostly applied when the product to be extracted is recognized as a high-value product. (Palmer & Ting, 1995) Some of the current known applications of SFE are presented in Table 1.7.

For instance, nutraceuticals are one of the fields of application of SFE: SFE of medicinal plants such as *Serenoa repens* or *Pygeum africanum* that are used to cure prostate adenoma, chamomile extract, etc.; SFE of oils, which represents an increasing market to substitute extracts obtained with organic solvents by traditional extraction techniques and to achieve new high-quality products. (Perrut, 2000)

Table 1.7 Some SFE applications in natural products and food industries. (Adapted from Mukhopadhyay, 2000)

Decaffeination of coffee and tea
Spice extraction
Deodorization of oils and fats
Extraction of vegetable oils from flaked seeds and grains
Flavors, fragrances, aromas, and perfumes
Hops extraction for bitter
Extraction of herbal medicines
Stabilization of fruit juices
Lanolin from wool
Deoiling of fast foods
Decholesterolization of egg yolk and animal tissues
Antioxidants from plant materials
Food colors from botanicals
Natural pesticides
Denicotinization of tobacco

This method has been used in chemical industries and in environmental, pharmaceutical, cosmetic, food and polymer applications, since Kurt Zosel patented SFE as a technique to decaffeinate coffee. (Perrut, 2000; Azmir et al., 2013)

In particular, supercritical CO₂ natural extracts have several known applications in food and pharmaceutical industries. Some of those applications are summarized in Table 1.8.

Table 1.8 Some SFE natural extracts applications. (Adapted from Mukhopadhyay, 2000)

Extract	Source	Commercial Applications
Ginger oil	<i>Zingiber officinalis</i>	Oriental cuisines Beverages
Pimento berry oil	<i>Pimenta officinalis</i>	Savory sauces Oral hygiene
Clove bud oil and oleoresin	<i>Eugenia caryophyllata</i>	Meats Pickles Oral hygiene
Nutmeg oil	<i>Myristica fragrans</i>	Soups Sauces Vegetable juices
Juniper berry oil	<i>Juniperus officinalis</i>	Alcoholic beverages Gin
Celery seed oil	<i>Apium graveolens</i>	Soups Vegetable juice
Vanilla absolute	<i>Vanilla fragrans</i>	Cream liqueurs Pure dairy foods
Cardamom oil	<i>Elletaria cardamomum</i>	Meats Pickles Spice blends
Aniseed oil	<i>Illicium verum</i>	Liqueurs Oral hygiene

Table 1.8 (Continued).

Extract	Source	Commercial Applications
Coriander oil	<i>Coriander sativum</i>	Curry Chocolate Fruit flavors
Pepper oleoresin and oil	<i>Piper nigrum</i>	Spices Meat Salad dressing
Cinnamon bark oil	<i>Cinnamomum zeylendium</i>	Baked goods Sweet products
Cumin oil	<i>Cuminum cyminum</i>	Mexican and Indian cuisines Pharmaceuticals
Marjoram oil	<i>Majorlana hortensis</i>	Soups Savoury sauces
Savory oil	<i>Satureja hortensis</i>	Soups Savoury sauces
Rosemary oil	<i>Rosemary officinalis</i>	Antioxidant Soups
Sage oil	<i>Salva officinalis</i>	Meat Sauces Soups
Thyme oil	<i>Thymus vulgaris</i>	Meat Pharmaceutical products
Paprika color	<i>Capsicum annum</i>	Soup Sauces Sweets

1.5. Aim and structure of the thesis

In this thesis, supercritical fluid extraction was explored as a reliable technology to extract and isolate anticancer bioactive compounds from different plants, namely *Lavandula angustifolia*, *Lavandula stoechas*, *Mentha spicata*, *Mentha x piperita* var. *citrata* and *Mentha pulegium*.

To achieve this goal, the work was divided in four major parts as schematically described in Figure 1.9.

In part 1, supercritical fluid extractions were performed in two distinct species of the genus *Lavandula* (*Lavandula angustifolia* and *Lavandula stoechas*) and three other species of the genus *Mentha* (*Mentha spicata*, *Mentha x piperita* var. *citrata* and *Mentha pulegium*). All extractions were performed at 50 °C and 250 bar, during 60 minutes with supercritical CO₂, plus 180 minutes with a mixture of CO₂ and ethanol (90:10, % v/v). The resulting samples were characterized in terms of global yield.

In part 2, the extracts were firstly screened for the presence of terpenes by TLC and then their phytochemical content, as well as its quantification, were evaluated by GC-MS.

In part 3, the different fractions of the extract obtained by supercritical fluid extraction were screened for their antioxidant activities using three different, but complementary assays (ORAC, HORAC and HOSC).

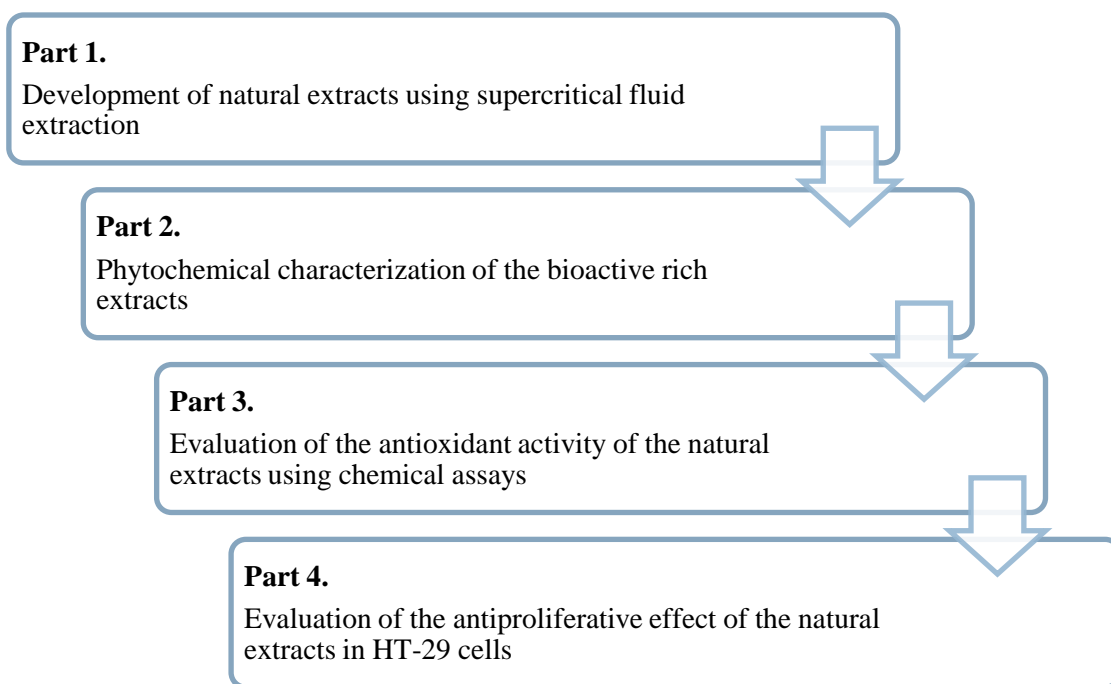

Figure 1.9 Structure of the thesis.

In part 4, the bioactive rich extracts were assessed for their antiproliferative effect in HT-29 human colorectal adenocarcinoma cells. The observed bioactivity was then correlated with the phytochemical composition of the extracts, in order to identify the compounds responsible for the anticancer activity.

2. Materials and Methods

2.1. Chemicals

For supercritical fluid extraction experiments, the chemicals used were carbon dioxide (CO₂) pure grade (99.95%) (Air Liquide, Algés, Portugal) and ethanol absolute, analytical grade (Scharlau, Barcelona, Spain).

For determination of the moisture content, a mixture of xylene isomers was used (Carlo Erba Reagents, Milan, Italy).

Chemicals used in thin layer chromatography for preparing Liebermann-Burchard reagent were Acetic Anhydride (Panreac, Barcelone, Spain) and sulfuric acid 96% (Panreac, Barcelone, Spain). Dichloromethane (analytical reagent grade) was used as mobile phase (Fisher Scientific, Loughborough, United Kingdom).

The chemicals used in the antioxidant activity assays were: 2',2'-azobis (2-amidinopropane) dihydrochloride (AAPH), 6-hydroxy-2,5,7,8-tetramethylchroman-2-carboxylic acid (Trolox), caffeic acid (C₉H₈O₄), disodium fluorescein (FL), cobalt fluoride tetrahydrate (CoF₂), picolinic acid (C₆H₅NO₂), Iron (III) chloride (FeCl₃), hydrogen peroxide (H₂O₂) and acetone ≥ 99.5% were purchased from Sigma-Aldrich (St. Quentin Fallavier, France). 2-hydroxypropyl-β-cyclodextrin (HP-β-CD) and ascorbic acid were also from Sigma-Aldrich (St. Quentin Fallavier, France). Sodium chloride (NaCl), potassium chloride (KCl) and monopotassium phosphate (KH₂PO₄) and sodium phosphate dibasic dehydrate (Na₂HPO₄·2H₂O) (Sigma-Aldrich, St. Quentin Fallavier, France) were used for phosphate buffer solution preparation (PBS). Sodium phosphate dibasic dehydrates (Na₂HPO₄·2H₂O) and sodium dihydrogenphosphate (NaH₂PO₄·H₂O) from Sigma-Aldrich (St. Quentin Fallavier, France) were used in sodium phosphate buffer solution preparation (SPB).

All cell culture media and supplements, namely fetal bovine serum (FBS), glutamine, RPMI 1640 and trypsin/EDTA were obtained from Invitrogen (Gibco, Invitrogen Corporation, Paisley, UK). Moreover, chemicals used for cell-based assays were: dimethyl sulphoxide (DMSO) (99.5%, Panreac, Barcelona, Spain) and methylthiazolyldiphenyl - tetrazolium bromide (MTT), all from Sigma-Aldrich (St. Quentin Fallavier, France).

2.2. Raw material preparation

Five aromatic plants from two distinct genus of the *Lamiaceae* family were studied.

The aerial parts, including stalks, leaves and flowering tops, of the two different species of the genus *Lavandula*, namely *Lavandula angustifolia* and *Lavandula stoechas*, along with three other species of the genus *Mentha*, namely *Mentha spicata*, *Mentha x piperita* var. *citrata* and *Mentha pulegium*, were collected between July and August 2013 at Mafra, Portugal.

Firstly, the collected plant material was dried at room temperature, in the absence of light, and then stored until required.

Later, the leaves and flowers of each plant were separated from the stalks and milled separately in a domestic chopper (Moulinex, A320R1, Lisbon, Portugal). The particle size of ground material was determined using an AS 200 basic vertical vibratory sieve shaker (Retsch, Haan, Germany), with a measuring range between 250 μm and 1000 μm . The processed plants were stored at room temperature, in the dark, until the day of the experiments.

2.3. Moisture content determination

The moisture content was determined by conventional Dean–Stark distillation, according to the procedure described by Jacobs (1939). This procedure suffered a few modifications and it is briefly described below.

The apparatus consisted of three main parts: a 250 mL flat bottom flask with an electrical heating mantle (Nahita, model 655), a 10 mL Dean–Stark receiver graded in steps of 0.1mL, attached with a Graham condenser in a reflux position. About 10 g of plant material were introduced in the flat bottom flask and then covered with 75 mL of a xylene mixture of isomers, which was used as distillation solvent. At the beginning of the experiment, the electrical heating was maximized until the collection of the first drops in the Dean–Stark receiver. Afterwards, the heating was reduced to a slower distillation rate. About 2 hours later, the heating was turned off and the system was allowed to cool for few minutes.

To make sure that no droplets of water were adhered to the side of the condenser or to the top of the Dean-Stark receiver, a small amount of xylene was introduced at the top of the Graham condenser.

After a while, the volume of water contained in the Dean-Stark receiver was read, and the moisture percentage was calculated assuming that the water volume was equivalent to its weight in grams, as follows:

$$\text{Moisture (\%)} = \frac{\text{Water volume (mL)}}{\text{Weight of the original plant sample(g)}} \times 100$$

2.4. Supercritical Fluid Extraction (SFE) procedure

The extractions were carried out in a prep supercritical fluid extractor (Thar Technology, Pittsburgh, PA, USA, model SFE-500F-2-C50) comprising a 500 mL cylinder extraction cell (extraction vessel) and two different separators (fraction collector 1 and fraction collector 2), each of them with 500 mL of capacity, with independent control of temperature and pressure. This apparatus is schematically represented in Figure 2.1.

Liquid carbon dioxide was delivered to the extraction vessel using a TharSFC P-50 high pressure pump (Thar Technology, Pittsburgh, PA, USA) and ethanol was delivered by a second similar high pressure pump. The solvents were then combined on a mixer and preheated on a

heat exchanger to a temperature of 45°C. The pressure on the extraction vessel was maintained by an automated back pressure regulator (TharSFC ABPR, Thar Technology, Pittsburgh, PA, USA), which was located between the extraction vessel and the first fraction collector.

For each experiment, the extraction vessel was filled with about 60 g of dried plant material and laboratory glass beads were placed on both endings of the cell, in order to achieve a uniform distribution of the solvent flow.

The extractions were performed using a two-step fractionated methodology, as described by Serra (2010). In this methodology, the first extraction step consisted in a pre-treatment with supercritical carbon dioxide in order to remove the CO₂-soluble compounds (the nonpolar and the lipophilic substances). This step consisted in 15 minutes of static extraction time followed by 60 minutes of dynamic extraction time. The second step lasted for 3 hours and a mixture of carbon dioxide and ethanol (90:10, %v/v) was used as extraction solvent, which allowed the extraction of polar compounds.

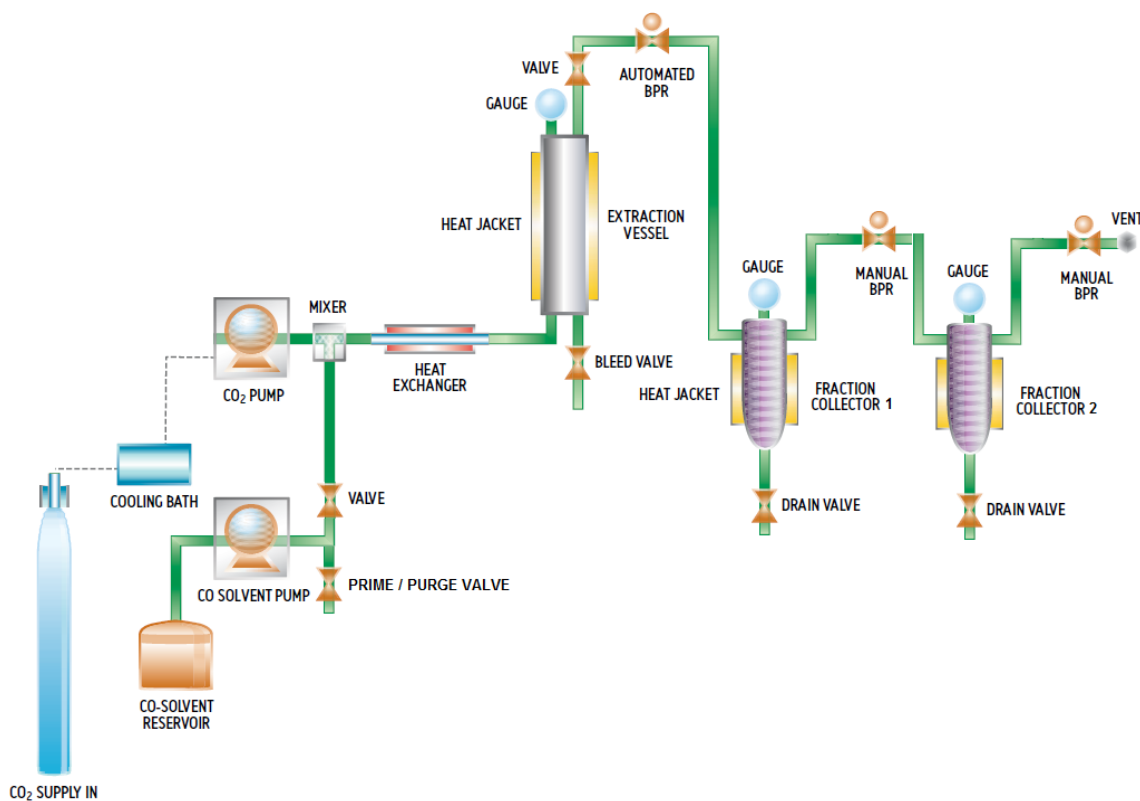

Figure 2.1 Schematic diagram of the supercritical fluid extraction apparatus. (Adapted from Waters, 2010)

The extractions were performed at a constant pressure of 250 bar, the temperature on the extraction vessel was set to be 50°C and the total solvent flow rate was set to 20 g/min, in all experimental assays.

The fractionation of the extract was accomplished by maintaining the first separator (fraction collector 1) at a pressure of 60 bar, and the second fraction collector at atmospheric pressure (approximately 1 bar). Both separators were kept at room temperature.

The selection of these operating conditions was based on previous studies conducted by Serra (2010), among others, which will be further discussed ahead.

The extracts were recovered in the first fraction collector at intervals of 30 minutes, during 4 hours. On the second fraction collector, a first fraction was recovered during the first hour of dynamic extraction time (first step), and then, a second fraction was collected throughout the 3 hours of the second step. The extracts recovered in the first separator presented a yellow or green color whereas the samples recovered in the second separator were colorless.

To ensure an accurate determination of extraction yield with time, both separators were washed with ethanol and the remaining material was recovered.

Moreover, in order to determine the experimental error associated to the yield values, the extractions were carried out in duplicates for each plant variety.

The ethanol present in the extracts was eliminated by evaporation at 40°C, under vacuum in the absence of light. The samples obtained were then kept in the dark, at 4°C, until further analysis.

Between extractions, the extraction apparatus was cleaned with pressurized ethanol for 15 to 20 minutes and then dried with supercritical CO₂.

2.5. Characterization of the extracts

2.5.1. Terpenes and steroids detection by Thin Layer Chromatography (TLC)

The initial detection of terpenes and steroids was carried out by thin layer chromatography.

TLC analysis of the extracts of aromatic plants was performed using silica gel plates (Merck KGaA, Darmstadt, Germany) with a 254 nm fluorescent indicator (aluminium base sheets 20x20 cm, thickness 200 µm, medium pore diameter 60 Å). Dichloromethane (100%) was used as mobile phase, whereas Liebermann-Burchard reagent was applied for the detection of terpenes and steroids in the aromatic plants extracts. Perillyl alcohol, limonene, linalool, lupeol and cholesterol (Sigma-Aldrich, USA) were used as standards. The Liebermann-Burchard reagent was prepared freshly, by adding carefully to 50 mL of absolute ethanol, while cooling on ice, 5 mL of acetic anhydride followed by 5 mL of concentrated sulfuric acid, as described by Wagner & Bladt (2001).

After elution, the TLC plates were sprayed with the reagent, and then heated for approximately 5 to 10 minutes at 100°C.

After revelation, the plates were examined under a UV lamp 365 nm and inspected for the existence of terpenes and steroids.

2.5.2. Identification and quantification of the extract's chemical components by Gas Chromatography – Mass Spectrometry (GC-MS)

The natural extracts were analyzed by gas chromatography coupled with mass spectrometry (GC-MS) in order to identify and quantify the compounds present in the different fractions collected. A Shimadzu GCMS- QP2010 (Shimadzu Corporation, Kyoto, Japan) gas chromatograph with a quadrupole mass spectrometer and electronic impact source was employed.

The separation of the compounds present in the supercritical fluid extracts was carried out using a DB-5MS (J&W Scientific) capillary column, 30 m × 0.25 mm I.D. and 0.25 µm phase thickness. The column temperature program started at 35°C and went up to 230°C, with a heating rate of 5°C/min. The temperature was then kept at 230°C for 15 minutes. The total flow of the carrier gas, helium, was set at 9.0 mL/min.

The samples were prepared and well sealed in vials prior to GC-MS analysis with a concentration of 75 mg/mL. One microliter of each sample was manually injected, in split injection mode, with a split ratio of 1:2, without previous derivatization. The injector temperature was 260°C and both MS interface and ion source temperatures were 250°C.

Mass spectrometry detection was performed in SCAN mode and samples were examined from m/z 29 to 299.

The GCMS Solutions software was used for data acquisition and the components of the natural extracts were identified by comparison with the mass spectra from libraries NIST21, NIST27, NIST107, NIST147 and WILEY229. The peak areas were also calculated using the same software, and were expressed as relative peak areas.

2.6. Antioxidant activity

2.6.1. Oxygen Radical Absorbance Capacity (ORAC)

The ORAC assay was one of the methods that were used to determine the antioxidant capacity of the natural extracts. This method evaluates the capacity of the antioxidant species, which are present in the extracts, to protect the disodium fluorescein (FL) from oxidation. In this assay, the reaction is catalyzed by peroxy radicals (ROO·), which are generated from AAPH.

This assay was carried out by following the procedure previously reported by Huang et al. (2002) modified for the FL800 microplate fluorescent reader as described by Feliciano et al. (2009).

Briefly, in a black 96-well microplate 25 µL of the appropriate sample dilutions and 150 µL of disodium fluorescein (2×10^{-7} mM) were added to each well. The microplate was then put in an FLx800 fluorescence microplate reader (BioTek Instruments, Winooski, VT, USA) at 37°C, for 10 minutes. The reaction took place at the same temperature and was started with 25

μL of AAPH (153 mM), which was added through the injector linked to the reader to each well. The fluorescence emitted by the reduced form of FL was recorded every 1 minute at the emission wavelength of 530 ± 25 nm and excitation wavelength of 485 ± 20 nm, for a period of 40 minutes, controlled by software Gen5. Phosphate buffer saline (PBS), 75 mM, pH=7.4, was used to prepare the solutions of AAPH and FL and then used as a blank. Solutions of 5, 10, 20, 30 and 40 μM of Trolox were prepared using the same PBS solution, and were used as control standards. All sample dilutions, the blank and Trolox concentrations, were analyzed at least in duplicates.

The ORAC values were calculated by a regression equation between the Trolox concentration and the net area under the FL decay curve, taking into account that the results of antioxidant capacity depend on sample concentration (Bolling et al., 2012). These results were expressed as Trolox equivalents per gram of extract ($\mu\text{mol TE/g}$ of extract).

2.6.2. Hydroxyl Radical Adverting Capacity (HORAC)

The HORAC assay was also utilized to determine the antioxidant capacity of the samples, this time based on their capacity of preventing hydroxyl radical ($\cdot\text{HO}$) using disodium fluorescein (FL) as a probe.

This assay was based on the method described by Ou et al. (2002), with slight modifications, and adapted for the FLx800 fluorescence microplate reader (BioTek Instruments, Winooski, VT, USA), as described by Serra (2010).

The hydroxyl radical was generated by a Co(II)-mediated Fenton-like reaction and, as in the ORAC assay, the fluorescence decay curve of FL was used to quantify the HORAC value.

Briefly, in a black 96-well microplate, 30 μL of appropriate sample dilutions were added to 170 μL of FL (9.28×10^{-8} M). Then, 40 μL of hydrogen peroxide (H_2O_2), 0.206 M, were added to each well of the microplate. Finally, the reaction was started by adding 60 μL of cobalt(II) fluoride (CoF_2), 1.15 mM, to the mixture previously placed in the microplate.

Sodium phosphate buffer (SPB), 75 mM, pH=7.4, was used to prepare the solution of FL, H_2O_2 and CoF_2 were prepared with Milli-Q water. Caffeic acid was used as a standard, and 50, 100, 150, 200 and 250 μM solutions in acetone:Milli-Q water (50:50 V/V) were used to create the calibration curve. Acetone:Milli-Q water (50:50 V/V) solution was used to prepare the samples and as a blank.

The fluorescence emitted by the reduced form of FL was measured and recorded every 1 minute during 60 minutes, at 37°C. The FLx800 fluorescence microplate reader was controlled by software Gen5 and was used with fluorescence filters for an excitation wavelength of 485 ± 20 nm and an emission wavelength of 530 ± 25 nm. All samples were analyzed in triplicates.

The HORAC values were calculated based on the caffeic acid calibration curve and on the average of the net area under the FL decay curves which presented a linear profile. The final results were expressed as caffeic acid equivalents per gram of extract ($\mu\text{mol CAE/g}$ of extract).

2.6.3. Hydroxyl Radical Scavenging Capacity (HOSC)

The HOSC assay is a method that measures the scavenging capacity of the antioxidant species, which are present in the samples, over hydroxyl radicals ($\cdot\text{HO}$), using disodium fluorescein (FL) as a probe.

This assay was based on the method described by Moore et al. (2006) and adapted for the FLx800 fluorescence microplate reader (BioTek Instruments, Winooski, VT, USA), as described by Serra et al. (2013).

The hydroxyl radical was generated using a Fenton-like $\text{Fe(III)}/\text{H}_2\text{O}_2$ reaction and, as in the ORAC and HORAC assays, the fluorescence decay curve of FL was used to quantify the HOSC value.

Briefly, in a black 96-well microplate, 30 μL of appropriate sample dilutions, followed by 40 μL of H_2O_2 (0.1990 M), were added to 170 μL of FL (9.28×10^{-8} M). The reaction was started by adding 60 μL of iron(III) chloride (FeCl_3), 3.43 mM, to the wells of the microplate.

SPB, 75 mM, $\text{pH}=7.4$, was used to prepare the solution of FL, and the solutions of H_2O_2 and FeCl_3 were prepared with Milli-Q water. Trolox was used as a standard, and 5, 10, 15, 20 and 30 μM solutions in acetone:Milli-Q water (50:50 V/V) were used to perform the calibration curve. Acetone:Milli-Q water (50:50 V/V) solution was used to prepare the samples and as a blank.

The fluorescence emitted by the reduced form of FL was measured and recorded every 1 minute, during 60 minutes, at 37°C. The FLx800 fluorescence microplate reader was controlled by software Gen5 and was used with fluorescence filters for an excitation wavelength of 485 ± 20 nm and an emission wavelength of 530 ± 25 nm. All samples were analyzed in duplicates, and the blank and the controls in triplicates.

The HOSC values were calculated by a regression equation between the Trolox concentration and the net area under the FL decay curve, taking into account that the results of antioxidant capacity depend on sample concentration (Bolling et al., 2012). These results were expressed as Trolox equivalents per gram of extract ($\mu\text{mol TE/g}$ of extract).

2.6.4. Lipophilic Oxygen Radical Absorbance Capacity (L-ORAC)

The L-ORAC assay was employed in order to understand the role played by the lipophilic antioxidants present in the extracts. This method uses a cyclodextrin as a solubility enhancer and evaluates the capacity of the lipophilic antioxidant species present in the samples,

to protect the disodium fluorescein (FL) from oxidation. In this assay, the reaction is catalyzed by peroxy radicals (ROO·), which are generated from AAPH.

This assay was carried out by following the procedure previously reported by Huang et al. (2002) modified for the FL800 microplate fluorescent reader.

The procedure is similar to that described for ORAC assay, with slight modifications. Briefly, the sample was properly diluted in solutions of 3%, 7% and 10% of 2-hydroxypropyl- β -cyclodextrin (HP- β -CD) in a 50% acetone:water mixture(v/v), and then shaken for about 1 hour at room temperature. Assays were also performed with ascorbic acid to serve as a basis for comparison with the sample.

With the exception of samples and Trolox standards, which were made in the HP- β -CD solvent, all other reagents (AAPH and FL), were prepared at 75 mM phosphate buffer (pH 7.4). In the final assay mixture (200 μ L), FL (2×10^{-7} mM) was used as a target of free radical attack and AAPH (153 mM) was used as a peroxy radical generator. The HP- β -CD solvent was used as the blank, and Trolox (5, 10, 20, 30 and 40 μ M) was used as the control standard. The fluorescence emitted by the reduced form of FL was measured in an FLx800 fluorescence microplate reader (BioTek Instruments, Winooski, VT, USA), which was controlled by software Gen5, that recorded every 1 min at the emission wavelength of 530 ± 25 nm and excitation wavelength of 485 ± 20 nm, for a period of 40 minutes.

Phosphate buffer saline (PBS), 75 mM, pH=7.4, was used to prepare the solutions of AAPH and FL and then used as a blank. Solutions of 5, 10, 20, 30 and 40 μ M of Trolox were prepared using the same PBS solution, and were used as control standards.

The L-ORAC final values were calculated by a regression equation between the Trolox concentration and the net area under the FL decay curve, taking into account that the results of antioxidant capacity depend on sample concentration (Bolling et al., 2012). These results were expressed as Trolox equivalents per gram of extract (μ mol TE/g of extract).

2.7. Cell-Based Assays

All cell-based assays were performed by Inês Silva, a colleague from Nutraceuticals and Controlled Delivery Lab.

2.7.1. Cell lines and culture

Human colorectal adenocarcinoma cell lines, HT-29 and Caco-2 were obtained from American Type Culture Collection (ATCC, USA) and Deutsche Sammlung von Microorganismen und Zellkulturen (DSMZ, Germany), respectively. Both cell lines were cultured in RPMI 1640 medium supplemented with 10% of heat-inactivated fetal bovine serum (FBS) and 2 mM of glutamine. The cells were incubated at 37 °C with 5% CO₂ in a humidified incubator and routinely grown as monolayer in 75 cm² culture flasks. The cell culture medium

and supplements were purchased from Invitrogen (Gibco, Invitrogen Corporation, Paisley, UK). The cell lines were split once or twice a week and the morphology and growth of the cells were monitored daily.

2.7.2. Cytotoxicity assay

Cytotoxicity assays of the extracts were performed using confluent Caco-2 cells. Despite this cell line origin (Caco-2 are cells from human colon adenocarcinoma), they can be used as an intestinal barrier model, as reviewed by Sambuy et al. (2005). Caco-2 cells, when cultured in special conditions, suffer spontaneous differentiation which leads to the formation of a monolayer, expressing a morphological and functional resemblance to mature enterocytes, healthy cells that can be found in human small intestine and colon.

This assay was performed as described by Serra (2010), with some modifications. The cells were seeded into 96-well culture plates at a cellular density of 2×10^4 cell/well, and were allowed to grow for 4 days until reaching confluency. The medium was changed every 48 hours. Natural extract samples were diluted in RPMI culture medium with 0.5% FBS and 2mM glutamine, and then added to the wells, except to the control cells which contained the solvent alone. The incubation with the natural extracts was carried out during 24 hours and the experiments were done in triplicates.

Cytotoxicity evaluation was performed by colorimetric MTT assay. The MTT (3-[4,5-dimethylthiazol-2-yl]-2,5 diphenyl tetrazolium bromide) assay is based on the reduction of MTT (a yellow tetrazole), to a purple formazan, by the mitochondrial reductase enzymes which are active in living cells. Therefore, the amount of formazan product is proportional to the number of viable cells.

Briefly, the medium was removed and 100 μ L of the reagent MTT (0.5mg/mL) was added to each well and the microplate was incubated for 4 hours. The reaction was stopped with DMSO (150 μ L/well) and formazan was quantified by of the absorbance at 570 nm in a microplate reader Spectrophotometer Powerwave XS (BioTek Instruments, Winooski, VT, USA). The results were expressed as percentage (%) of cell viability relative to the control (cells incubated only with culture medium, without the natural extracts). The IC₅₀ values (index of cytotoxicity – the concentration of extract necessary to decrease 50% of the cell viability) were calculated through the logarithm of the concentration.

2.7.3. Antiproliferative Assay

The antiproliferative assays of the natural extracts were performed on human colon adenocarcinoma cell line (HT-29).

The assay was performed as described by Serra (2010), with a few alterations. Briefly, the cells were seeded in 96-well microplates at a cellular density of 1×10^4 cell/well. After 24

hours of incubation at 37 °C with 5% CO₂ in a humidified atmosphere, the medium that was in the wells was removed and the cells were incubated with the natural extracts (from the five different plants) which were diluted in RPMI medium supplemented with 0.5% of FBS. After 24 hours, the medium was removed from the wells and the cell viability was estimated using the colorimetric MTT assay, as reported for cytotoxicity assays.

The results were expressed as percentage (%) of cell viability relative to the control and the effective concentration values (EC₅₀ – concentrations that inhibit HT-29 cell proliferation by 50%) were calculated through the logarithm of the concentration. The experiments were performed in triplicates.

3. Results and Discussion

Supercritical fluid extraction technology was applied to five different natural matrices, namely *L. angustifolia*, *L. stoechas*, *M. spicata*, *M. piperita* var. *citrata* and *M. pulegium*, harvested in Mafra, Portugal, in order to extract different bioactive compounds with promising anticancer activity.

Before extractions, the previously dried and milled plants were characterized in terms of mean particle diameter and moisture content. After performing the extractions, the global yield of the natural extracts, in terms of dry weight (% g/g), was evaluated, as well as their phytochemical content, which was firstly screened by thin layer chromatography, and then identified and quantified by GC-MS analysis. Furthermore, the antioxidant and antiproliferative activities of the extracts were evaluated using both chemical and cell-based assays, respectively.

3.1. Development of natural extracts using supercritical fluid extraction

In this work, five plants of *Lamiaceae* family, from two different genus, were studied, namely *L. angustifolia* and *L. stoechas* from *Lavandula* genus and *M. spicata*, *M. piperita* var. *citrata* and *M. pulegium* from *Mentha* genus.

Prior to extractions, the plants were air-dried and processed. Then, the plant material was sieved using suitable sieves and a vertical vibratory sieve shaker, in order to determine the mean particle diameter. The moisture content of the dried plants was also determined and the extractions were performed (see Table 3.1).

In order to extract anticancer bioactive compounds from these natural sources, such as terpenes and fatty acids, supercritical fluid extraction technique was employed. All extractions were performed at 50°C and 250 bar, and the methodology comprised two steps: a first step with supercritical CO₂ for 60 minutes, followed by a second step with a mixture of CO₂ and ethanol (90:10 v/v), for 180 minutes. The extraction was carried out for a total of 4 hours and the extracts were recovered in different flasks every 30 minutes.

The selection of extraction operating conditions (temperature, pressure, extraction time and solvent mixture) was based on previous studies conducted by Serra (2010). According to Lee et al. (2001), a supercritical CO₂ extraction at 50° C and 200 bar can efficiently isolate perillyl alcohol, a monoterpene known for its chemopreventive and cytotoxic activities against a wide variety of cancer cell lines (Sundin et al., 2012). However, it is expected that the recovery of lipids increases with a pressure and temperature increase (Herrero et al., 2006). Serra (2010) realized that, with an increase of the operating pressure and with the addition of ethanol as a co-solvent, the extraction of bioactive compounds could be enhanced. One of the conclusions of Serra's (2010) study was that the extracts obtained from the extraction with CO₂:EtOH (90:10,

%v/v), after a pretreatment of the raw material with supercritical CO₂ during 1 hour, originated an extract with high antiproliferative activity in human HT-29 colon cancer cells.

Therefore, knowing that the chosen plants are rich sources of terpenes, similar operating conditions were applied, in order to successfully extract bioactive compounds with anticancer activity. Moreover, it is well known that fatty acids naturally occur in plants (Hitchcock & Nichols, 1971), and that some of these compounds have promising antiproliferative activities (Hayashi et al. 1992; Yoo et al., 2007). Thus, it would be advantageous that they could be extracted as well. According to Reverchon (1997), at low CO₂ densities (temperatures between 40 and 50°C and pressures between 80 and 90 bar), terpenes are much more soluble than fatty acids. However, at high CO₂ densities (temperatures between 40 and 50°C and pressures between 100 and 200 bar), terpenes are completely miscible in supercritical CO₂, and the solubility of the fatty acids becomes high. Moreover, the fatty acids extraction yields could be increased considerably by adding of ethanol as a co-solvent (Sánchez-Camargo et al., 2012). Consequently, it was expected that, under the selected conditions, fatty acids could be extracted as well, since there are several studies that used similar supercritical CO₂ densities, and successfully isolated these compounds. (Cheung, 1999; Botelho et al., 2014).

Nonetheless, slight adjustments were made to the methodology presented by Serra (2010). The dynamic extraction time, for instance, was extended for an hour and a half, in order to improve the efficiency of the recovery yield. According to Shilpi et al., (2013) it is possible to do so if the contact of the supercritical solvent with the raw material is maximized. The pressure applied in the first collection vessel (fraction collector 1) was also modified from atmospheric pressure to 60 bar, in order to perform an extraction in more than one step and obtain a fractional extraction. According to Reverchon and De Marco (2006) and Filip et al. (2013), this operation induces the selective precipitation of different compounds as a function of their different saturation conditions in the SCF, by changing the temperature and/or the pressure conditions. This enables the achievement of extracts with different compositions.

Table 3.1 summarizes the results obtained for the experiments of moisture content and global yields (% g/g) determination. All extractions were performed in duplicates, in order to determine the experimental errors and the results presented in Table 3.1 represent the average between those duplicates. Moreover, the yield results were calculated taking into account the moisture content of each of the air dried plants. The mean particle diameter was calculated based on the mean size distribution, as described by Coulson and Richardson (2002).

The highest extraction yield was obtained for the extract of *L. angustifolia*, whereas the lowest yield was obtained for the extract of *M. spicata*.

Table 3.1 Natural matrices initial characterization: mean particle size, moisture content and global yield of the extracts obtained from the SFE performed.

Sample		Mean Particle Diameter (μm)	Moisture Content (%)	Global Yield (% g/g) *
<i>Lavandula spp.</i>	<i>Lavandula angustifolia</i>	496	7.00 \pm 0.71	4.84
	<i>Lavandula stoechas</i>	509	4.50 \pm 0.71	4.61
<i>Mentha spp.</i>	<i>Mentha spicata</i>	515	10.25 \pm 0.35	2.03
	<i>Mentha x piperita</i> var. <i>citrata</i>	520	9.50 \pm 0.00	3.19
	<i>Mentha pulegium</i>	485	7.00 \pm 0.71	3.56

*SD < 15%.

There seems to be a relationship between large mean particle diameter, high moisture content and lowest extraction yield. An example is the extract of *Mentha spicata*, which presented the lowest global yield, the higher moisture content and the second larger particle size. In fact, and although it is not linear for small differences of size, it is known that the extraction yield decreases with the increasing of the particle size (Shilpi et al., 2013), and for matrices with high moisture contents, yield also decrease (Nobre et al., 2009; Durante et al., 2014). The extraction rate is enhanced with the decreasing of the particle sizes since the interfacial area is increased and the inner structures of the particles are destroyed. (Shilpi et al., 2013) The moisture content of the plant material also plays an important role during the extraction of compounds since, according to Sun & Temelli (2006), for the supercritical fluid extraction of non-polar compounds, the presence of water within the sample can inhibit the extraction of some compounds. Since the particle sizes are not so different among the matrices, the moisture content factor might explain the low yield presented by the extracts of *Mentha spicata* and *Mentha x piperita* var. *citrata*.

3.2. Phytochemical characterization of the bioactive rich extracts

For the studied aromatic plants, twelve fractions were collected during the extractions. Given the large number of samples, before further analyses, each fraction of the extracts was screened by TLC for the presence of terpenes (see Appendix A), in order to understand which fractions had similar profiles. After the TLC analysis, the similar fractions recovered in the first collector (at a pressure of 60 bar and room temperature) were combined into 3 different samples. The three fractions collected in the second fraction collector (atmospheric pressure and temperature), were discarded, since their TLC profile was different from all the others fractions (see numbers 2, 4 and 13 in the figures represented in Appendix A). The mixtures of the different extract fractions are summarized in Table 3.2.

The fractions of the extracts were combined in the samples A, B and C, and these samples were submitted to new analysis by TLC, in order to compare the profiles between

fractions of the same species and between fractions of different plant species. The results are presented in Figure 3.1.

Table 3.2 Mixtures of the fractions of the natural extracts, obtained by SFE, with similar profiles.

	Sample ID		Time of collection (fraction collector 1)
<p>1st Step</p> <p>Supercritical Fluid Extraction with CO₂ P = 250 bar T = 50°C t_{dynamic} = 60 minutes</p>	A	1 st fraction 2 nd fraction	0-30min 30-60 min
<p>2nd Step</p> <p>Enhanced Solvent Extraction with CO₂:EtOH (90:10, % v/v) P = 250 bar T = 50°C t_{dynamic} = 180 minutes</p>	B	3 rd fraction 4 th fraction 5 th fraction	60-90 min 90-120 min 120-150 min
	C	6 th fraction 7 th fraction 8 th fraction 9 th fraction	150-180 min 180-210 min 210-240 min Depressurization / Cleaning 1 st fraction collector

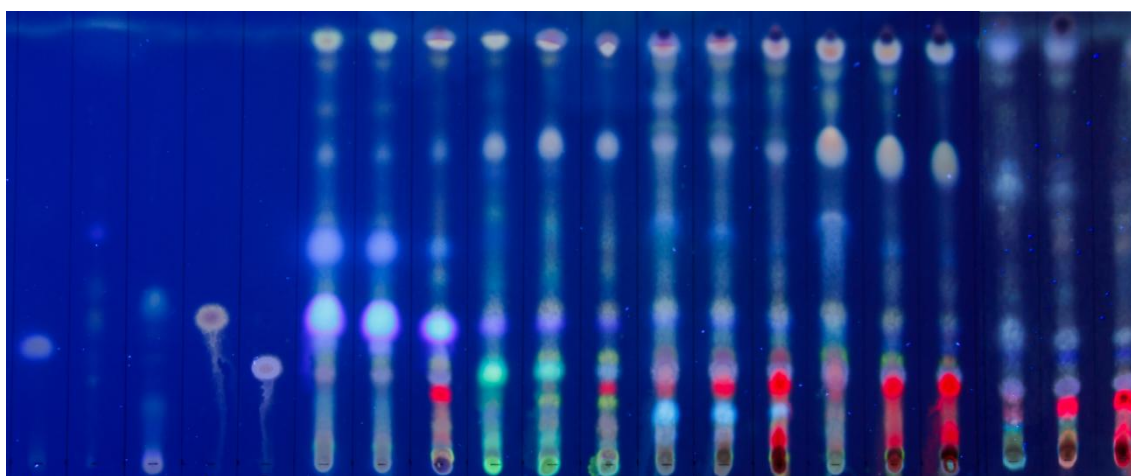

1 2 3 4 5 6 7 8 9 10 11 12 13 14 15 16 17 18 19 20
Figure 3.1 TLC analysis of the natural extracts, obtained by SFE, to reveal terpenes and steroids. Legend:
 1 – perillyl alcohol standard; 2 – limonene standard; 3 – linalool standard; 4 – lupeol standard; 5 – cholesterol standard; 6 – *L. angustifolia* extract (fraction A); 7 – *L. angustifolia* extract (fraction B); 8 – *L. angustifolia* extract (fraction C); 9 – *L. stoechas* extract (fraction A); 10 – *L. stoechas* extract (fraction B); 11 – *L. stoechas* extract (fraction C); 12 – *M. spicata* extract (fraction A); 13 – *M. spicata* extract (fraction B); 14 – *M. spicata* extract (fraction C); 15 – *M. pulegium* extract (fraction A); 16 – *M. pulegium* extract (fraction B); 17 – *M. pulegium* extract (fraction C); 18 – *M. piperita* var. *citrata* extract (fraction A); 19 – *M. piperita* var. *citrata* extract (fraction B); 20 – *M. piperita* var. *citrata* extract (fraction C).

This simple and quick method allowed to realize the complexity of the extracts in terms of terpenes, given the high number of spots. However, due to that high number of spots, some of them eventually overlapped, which made it difficult to identify them through the standards.

Therefore, further analyses were needed to fully understand the composition of the natural extracts. Nevertheless, the results were very interesting and revealed the similarities between the profiles among the extracts of the plants of the same genus.

The study of the chemical content of the fractions A, B and C of the natural extracts, as well as its quantification, were performed by GC-MS, as mentioned.

In general, the obtained chromatograms point to extracts significantly more complex than those presented in the literature for essential oils obtained by hydrodistillation or SFE.

It is important to refer that all extracts were manually injected in the gas chromatograph (GC) and the analysis were performed without an internal standard. An internal standard is a chemical substance that is similar to those found in the sample, but does not exist in it and does not co-elute with any compound in the sample. This substance is added in a constant amount to all the samples, prior to the analyses. With this known amount of standard, it would be possible to correct instrumental errors as for instance the error associated with the loss of sample during the injection, as the volume is very small. Therefore, the use of an internal standard is important for an accurate analysis of the samples. However, as stated above and as can be confirmed by the chromatograms shown in the Appendix B, the composition of the extracts were found to be extremely complex. Consequently, finding an internal standard that would respect the above mentioned criteria would be quite a challenge. Nonetheless, an internal standard ^{13}C labeled could be used, for example. However, these standards are very expensive, and the investment might not compensate in this initial phase.

The components present in the natural extracts were identified by comparison with the mass spectra from libraries (similarity index > 88%). The existence of some of the identified compounds was confirmed through the data contained in the literature as well. However, the works with plants focus mainly on their essential oils. Essential oils are mainly formed by hydrocarbon and oxygenated monoterpenes and by hydrocarbon and oxygenated sesquiterpenes. (Reverchon & De Marco, 2006), which are only a part of the extracts obtained in the referred conditions by SFE. Even though the conditions were not the same and, sometimes, neither the extraction technique, some of the compounds were compared to those that were found in the literature. It is also important to note that it is possible to see different compositions, since the geographical location of the plants was not the same as the ones found in the literature. In future work, it would be interesting to test a mixture of alkanes, in order to confirm the order of elution of the compounds, by the retention indices.

After the chemical compounds that were present in the natural extracts had been identified through comparison with spectra from libraries, their percentages were determined from their relative peak areas.

During the analysis, and through the mass spectra, some peaks were identified as being saturated in the samples. This represents a problem, since the percentages presented do not correspond to reality. In a first approach, a random sample was injected again with a split ratio of 1:50, in order to understand if the peaks would no longer be saturated. However, it was perceived that the peaks did not cease to be saturated, and the remaining peaks were no longer visible. Therefore, and in order to overcome this problem, the saturated peaks were removed from the calculation as if they were not present in the sample. The results are presented in two different tables: a first one, where are presented the saturated compounds that were present in the samples; and a second one, where the saturated peaks were removed from the calculations, and the other compounds that were present in the samples are presented. Consequently, in this second table, the 100% corresponds to the sum of all peak areas, excluding the compounds whose peaks were saturated, which are present in the sample in a high amount.

Given the complexity of the extracts, the discussion will be restricted to the major components identified for the different natural extracts (including the saturated ones).

The results obtained for each fraction of the extracts are summarized in the tables below and the peaks are numbered and presented in order of elution in a DB-5MS column.

Lavandula angustifolia

A total of 40 compounds were identified in the three fractions of the SFE extract of *Lavandula angustifolia*. The results are shown in Tables 3.3 and 3.4, and the main compounds are highlighted in bold.

Table 3.3 Major extract constituents of *L. angustifolia* determined by GC-MS.

Peak no.	Major Compounds *	A			B			C		
		Ret. Time (min)	Area %	Sim. Index %	Ret. Time (min)	Area %	Sim. Index %	Ret. Time (min)	Area %	Sim. Index %
4	Linalool	16.508	> 20.11	96	16.574	> 16.9	96			
6	Camphor	17.925	> 9.9	97	17.958	> 8.48	95			
9	Borneol	18.703	> 5.44	94	18.750	> 5.84	94	18.738	> 4.51	96
20	Linalyl acetate	20.953	> 5.35	96	20.973	> 5.16	96			
	Other compounds		< 59.2			< 63.62			< 95.49	
	TOTAL		100			100			100	

*Saturated peaks

Table 3.4 Other extract constituents of *L. angustifolia* determined by GC-MS.

Peak no.	Other Compounds	A			B			C		
		Ret. Time (min)	Area %	Sim. Index %	Ret. Time (min)	Area %	Sim. Index %	Ret. Time (min)	Area %	Sim. Index %
1	Eucalyptol	14.100	5.31	96	14.100	3.78	95	14.137	0.64	96
2	Cis-sabinenehydrate	15.442	1.2	91	15.440	1.38	88	15.458	0.48	88
3	Cis-linalool oxide	15.977	0.52	95	15.973	0.71	94	15.992	0.22	94

Table 3.4. (Continued).

Peak no.	Other Compounds	A			B			C		
		Ret. Time (min)	Area %	Sim. Index %	Ret. Time (min)	Area %	Sim. Index %	Ret. Time (min)	Area %	Sim. Index %
4	Linalool							16.538	10.58	96
5	Trans-pinocarveol	17.708	0.63	94	17.741	0.55	94	17.712	0.3	95
6	Camphor							17.924	4.13	96
7	Pinocarvone				18.381	0.18	91			
8	Lavandulol	18.460	4.45	95	18.508	4.71	96	18.490	2.3	96
10	Epoxylinolol	18.788	0.3	92	18.817	0.27	90	18.814	0.18	90
11	4-terpineol	18.940	5.79	95	18.969	5.6	95	18.962	2.74	96
12	2.6-dimethyl-3.7-Octadiene-2.6-diol	19.229	1.24	88	19.279	1.82	94	19.304	1.28	92
13	Lavandulol oxide	19.358	0.33	90	19.383	0.58	94	19.383	0.11	88
14	Alpha-terpineol	19.392	1.16	88	19.408	1.24	91	19.417	0.72	88
15	Dihydro-carveol				19.541	0.29	94			
16	(-)-Verbenone	19.758	0.23	92	19.773	0.25	96	19.783	0.13	96
17	Trans-carveol				20.117	0.2	91	20.125	0.15	91
18	Carvone	20.826	1.85	94	20.842	2.18	94	20.843	1	93
19	Linalyl acetate							20.961	3.12	96
20	2.6-dimethyl-1.7-Octadiene-3.6-diol	21.657	0.49	90	21.677	0.94	93	21.728	0.79	92
21	Citrol	21.910	0.4	91	21.912	0.47	92	21.919	0.31	89
22	(+)-Verbenone	22.644	0.29	90	22.650	0.43	89	22.675	0.31	88
23	1-hexadecanol							24.816	0.52	92
24	Cis-caryophyllene	25.536	1.55	94	25.542	1.76	94	25.544	0.78	94
25	Coumarin	26.054	1.59	95	26.083	2.38	96	26.174	5.24	97
26	(Z)-beta-Farnesene	26.361	1.94	92	26.365	2.19	93	26.368	1.28	92
27	Germacrene-D	27.096	0.91	93	27.101	1.02	93	27.106	0.56	92
28	Geranyl propionate	27.592	0.74	88	27.592	0.79	88	27.600	0.37	88
29	Caryophyllene oxide	29.574	6.3	93	29.586	5.3	94	29.596	2.71	93
30	Alpha-bisabolol	31.908	3.57	93	31.916	3.08	94	31.932	1.69	94
31	Herniarin	32.824	0.73	91	32.842	1.08	92	32.940	3.2	92
32	Myristic acid	33.525	0.19	94	33.542	0.29	95	33.592	0.65	95
33	Neophytadiene	35.046	1.32	95	35.042	0.77	94	35.074	3.95	96
34	Hexahydrofarnesyl acetone	35.163	0.91	88	35.167	0.53	88	35.186	0.49	91
35	Palmitic acid	37.679	5.83	94	37.692	5.44	94	37.758	5.68	94
36	Phytol	40.327	1.02	95	40.333	0.89	94	40.355	2.03	95
37	Linoleic acid	40.983	13.3	92	41.000	10.88	91	41.045	8.49	88
38	Stearic acid	41.350	1.44	88	41.366	1.39	92	41.402	1.5	95
39	Palmitic aldehyde	42.413	0.59	93	42.417	0.43	93	42.431	0.16	93
40	1-nonadecanol	43.490	0.2	95	43.492	0.35	95			
	Unidentified paraffins	-	4.77	-	-	5.15	-	-	4.73	-
	Unidentified compounds		28.91 ⁺			30.70 ⁺			26.48 ⁺	
	TOTAL		100			100			100	

⁺Calculations performed excluding the saturated peaks.

The major components identified in fraction A were eucalyptol, linalool, camphor, borneol, lavandulol, 4-terpineol, linalyl acetate, caryophyllene oxide, palmitic acid and linoleic acid. It is important to refer that the peaks that correspond to linalool, camphor and linalyl acetate were saturated. Therefore, it is likely that the percentages presented are, in fact, higher.

The major components identified in fraction B were the same, but in different percentages (see Tables 3.3 and 3.4).

The major components identified in fraction C were linalool, camphor, borneol, coumarin, palmitic acid and linoleic acid. In this fraction, only the peak of borneol remained saturated.

The chemical compositions of the three fractions revealed to be mainly composed of oxygenated monoterpenes (eucalyptol, linalool, camphor, lavandulol, borneol, 4-terpineol and linalyl acetate), oxygenated sesquiterpenes (caryophyllene oxide) and fatty acids (palmitic and linoleic acids). These results are according to Danh et al. (2012) and Da Porto et al. (2009) that found that main compounds of *Lavandula angustifolia* essential oils obtained by SFE technique were linalool, linalyl acetate, camphor, borneol, 4-terpineol and eucalyptol, in this order, which correspond to some of the compounds that were identified in the extract. The concentrations presented by these authors are closer to the concentrations presented by these compounds in fraction A, since the conditions applied in this fraction are the best of the three to extract essential oils, due to CO₂ polarity.

Lavandula stoechas

In the three fractions of the SFE extract of *Lavandula stoechas*, a total of 52 compounds were identified. The results are presented in Tables 3.5 and 3.6, and the main compounds are highlighted in bold.

Table 3.5 Major extract constituents of *L. stoechas* determined by GC-MS.

Peak no.	Major Compounds *	A			B			C		
		Ret. Time (min)	Area %	Sim. Index %	Ret. Time (min)	Area %	Sim. Index %	Ret. Time (min)	Area %	Sim. Index %
1	Eucalyptol	14.229	> 3.84	96						
4	D-fenchone	16.157	> 3.92	98						
5	L-fenchone	16.213	> 1.56	92	16.109	> 3.7	93			
8	Camphor	18.296	> 19.81	96	18.088	> 13.22	95			
	Other compounds		< 70.87			< 83.08			100	
	TOTAL		100			100			100	

*Saturated peaks

Table 3.6 Other extract constituents of *L. stoechas* determined by GC-MS.

Peak no.	Other Compounds	A			B			C		
		Ret. Time (min)	Area %	Sim. Index %	Ret. Time (min)	Area %	Sim. Index %	Ret. Time (min)	Area %	Sim. Index %
1	Eucalyptol				14.173	1.91	96	14.194	0.3	96
2	4-Methyl-4-vinylbutyrolactone	14.497	0.53	97	14.433	0.13	95			
3	Cis-linalool oxide	15.571	2.15	95	15.511	0.48	93	15.530	0.12	89
5	L-fenchone							16.088	0.97	98
6	Linalool	16.825	5.66	97	16.583	1.62	97	16.519	0.54	97
7	Fenchol	17.503	0.73	95	17.222	0.14	92			
8	Camphor							17.971	5.64	97
9	Camphene hydrate	18.372	0.47	88						
10	Lavandulol	18.540	0.62	93						
11	Borneol	18.808	0.59	96	18.765	0.23	96	18.775	0.1	95
12	Trans-linalool oxide	18.911	0.55	94	18.869	0.19	96			
13	Menthol				18.950	0.15	91	18.959	0.88	97
14	4-terpineol	19.035	1.27	93	18.997	0.33	93			
15	Cuminol				19.258	0.6	92			
16	2.6-dimethyl-3.7-Octadiene-2.6-diol	19.434	0.77	92	19.359	0.35	94	19.368	0.3	95
17	Alpha-Terpineol	19.517	0.93	92	19.475	0.36	89			
18	Dihydrocarveol	19.649	0.26	94						
19	Verbenone	19.866	1.03	96	19.826	0.35	96	19.525	0.21	92
20	Fenchyl acetate	20.073	0.24	95						
21	Trans-carveol	20.230	0.52	95	20.195	0.13	94			
22	Pulegone	20.722	0.45	96						
23	Carvone	20.932	2.22	93	20.892	0.78	94	20.900	0.49	91
24	Linalyl acetate	21.006	1.56	97	20.984	0.54	97	20.988	0.19	94
25	1.7.7-trimethyl-bicyclo[2.2.1]heptane-2.5-dione	21.611	0.85	94	21.583	0.23	93	21.592	0.13	91
26	2.6-dimethyl-1.7-Octadiene-3.6-diol				21.808	0.26	88			
27	Bornyl acetate	22.001	1.84	92	21.981	0.65	94			
28	Myrtenylacetate	23.077	1	95	23.059	0.29	93			
29	1-Hydroxymethyl-7.7-dimethylbicyclo[2.2.1]heptan-2-one				23.276	0.19	91			
30	1-methyl-4-(1-methylethenyl)-1.2-cyclohexanediol				23.812	0.49	95	23.819	0.52	91
31	1-tetradecene							24.860	0.58	97
32	S-(+)-5-(1-Hydroxy-1-methylethyl)-2-methyl-2-cyclohexen-1-one	26.028	0.37	92	25.992	0.29	95	26.000	0.31	89
33	1-dodecanol							27.033	0.12	89
34	Eremophilene	27.333	0.62	92	27.327	0.26	91			
35	Caryophyllene oxide	29.646	0.59	95						
36	1-pentadecene							29.796	0.64	95

Table 3.6. (Continued).

Peak no.	Other Compounds	A			B			C		
		Ret. Time (min)	Area %	Sim. Index %	Ret. Time (min)	Area %	Sim. Index %	Ret. Time (min)	Area %	Sim. Index %
37	Epiglobulol	29.976	1.74	92	29.950	0.79	92	29.955	0.59	91
38	Ledol	30.191	0.57	93	30.175	0.18	92	30.188	0.1	89
39	Tau-Cadinol	31.051	1.28	89	31.035	0.59	90	31.044	0.86	90
40	Myristic acid	33.817	1.67	95	33.740	0.9	96	33.736	0.85	95
41	Ledene	34.125	0.56	88						
42	1-heptadecene							34.226	0.54	94
43	Neophytadiene				35.105	0.13	92	35.108	0.4	95
44	Hexahydrofarnesyl acetone				35.241	0.57	92	35.242	0.52	89
45	Dibutyl phthalate	37.587	0.22	92						
46	Palmitic acid				37.842	4.51	88	37.824	6.28	89
47	Palmitic acid ethyl ester	38.258	0.46	89						
48	Phytol	40.442	0.17	91	40.425	0.3	93	40.424	0.93	94
49	Linoleic acid	40.967	1.01	91	40.983	1.41	91	40.954	1.73	92
50	Steric acid	41.525	1.01	95	41.517	1.86	93	41.489	2.65	95
51	Octadecyl chloride			95	43.730	0.26	88			
52	Tetratetracontane							52.117	6.95	95
	Unidentified Paraffins	-	1.42	-	-	2.47	-	-	9.99	-
	Unidentified compounds		64.07 ⁺			75.08 ⁺			55.57 ⁺	
	TOTAL		100			100			100	

⁺Calculations performed excluding the saturated peaks.

The identification of the compounds present in the fractions obtained for this extract was extremely difficult, since the chromatograms of the *Lavandula stoechas* extract were found to be much more complex in terms of composition than the others and the base line assumed a bell form. There were even some peaks that stood out from the others, but it was not possible to identify them through the library of spectra.

Still, the major components identified in fraction A were eucalyptol, D-fenchone, L-fenchone, camphor and linalool. All the compounds referred, have revealed to be saturated in the chromatograms obtained. Therefore, the percentages presented might be higher.

In fraction B, camphor continued to show the most intense peak, followed by L-fenchone and palmitic acid. Both camphor and L-fenchone peaks remained saturated, as in fraction A.

The major components identified in fraction C were camphor, palmitic acid and tetratetracontane. In this fraction, there were no saturated peaks.

The chemical compositions of the fractions A and B revealed to be mainly composed of oxygenated monoterpenes (eucalyptol, fenchone, linalool and camphor), whereas in fraction C the most prominent peaks were fatty acids and higher molecular weight compounds (paraffins or saturated hydrocarbons). Results obtained for fraction A are according to results reported by

Zuzarte et al. (2013) and Giray et al. (2008). These authors prepared essential oils extracts from *Lavandula stoechas* using hydrodistillation and subcritical water extraction respectively. They found that the major compounds present in the oil were camphor, fenchone and eucalyptol.

Mentha spicata

A total of 65 compounds were identified in the fractions of the extract of *Mentha spicata*. The results are summarized in Tables 3.7 and 3.8, and the main compounds are highlighted in bold.

Table 3.7 Major extract constituents of *M. spicata* determined by GC-MS.

Peak no.	Major Compounds *	A			B			C		
		Ret. Time (min)	Area %	Sim. Index %	Ret. Time (min)	Area %	Sim. Index %	Ret. Time (min)	Area %	Sim. Index %
17	Carvone	21.033	> 26.9	94	21.175	> 15.42	92			
55	Phytol				40.425	> 2.46	94	40.407	> 4.53	96
	Other compounds		< 73.1			< 82.12			< 95.47	
	TOTAL		100			100			100	

*Saturated peaks

Table 3.8 Other extract constituents of *M. spicata* determined by GC-MS.

Peak no.	Other Compounds	A			B			C		
		Ret. Time (min)	Area %	Sim. Index %	Ret. Time (min)	Area %	Sim. Index %	Ret. Time (min)	Area %	Sim. Index %
1	3-octanol	13.108	0.15	97						
2	Limonene	14.049	0.6	95	14.058	0.34	95			
3	Eucalyptol	14.158	1.45	95	14.172	0.62	95			
4	Trans-sabinene hydrate	15.495	1.84	93	15.524	1.05	92	15.494	0.11	92
5	Cis-linalool oxide	16.034	0.18	92						
6	Linalool	16.520	7.62	96	16.579	4.35	96	16.486	0.72	97
7	Nonanal	16.649	0.15	93	16.667	0.16	96			
8	Camphor	17.933	2.25	97	17.949	1.11	96	17.928	0.13	95
9	Lavandulol	18.491	0.68	96	18.532	0.59	96			
10	Borneol	18.733	1.33	95	18.783	1.13	95	18.733	0.18	95
11	Menthol							18.925	0.45	96
12	4-terpineol	18.975	1.27	95	19.003	1.17	94			
13	Dihydrocarvone	19.521	2.53	92	19.550	1.76	90			
14	Dihydrocarveol	19.663	10.42	96	19.842	7.74	95	19.599	1.27	96
15	Trans-Carveol	20.266	0.5	95	20.444	0.42	95			
16	Cis-carveol	20.712	1.68	95	20.734	0.13	88	20.576	0.19	96
17	Carvone							20.909	3.51	94
18	Linalyl acetate							20.967	0.18	94
19	Dihydrocarvyl acetate	23.080	2.94	94	23.115	2	94	23.075	0.36	93
20	Piperitenone	23.508	0.39	88	23.533	0.38	88			
21	Trans-carvyl acetate	24.000	1.77	94	24.030	1.36	94	23.998	0.19	95

Table 3.8 (Continued).

Peak no.	Other Compounds	A			B			C		
		Ret. Time (min)	Area %	Sim. Index %	Ret. Time (min)	Area %	Sim. Index %	Ret. Time (min)	Area %	Sim. Index %
22	Piperitenone oxide	24.093	0.16	89						
23	Beta-bourbonene	24.625	1.5	97	24.646	0.95	97	24.626	0.13	96
24	Beta-elemene	24.775	0.35	92	24.789	0.33	90			
25	1-tridecene			94	24.850	0.15	97	24.833	0.27	97
26	Cis-Jasmone	24.935	0.34	91	24.956	0.38	94			
27	(-)-Isoledene	25.238	0.17	94						
28	Cis-caryophyllene	25.567	2.23	93	25.589	1.48	95	25.566	0.24	94
29	Coumarin				26.107	0.14	96	26.650	0.12	
30	Alpha-Cubebene				26.235	0.55	90			
31	(Z)-beta-Farnesene	26.383	1.02	94	26.403	0.93	94			
32	Alpha-humulene	26.480	0.32	93	26.493	0.28	93			
33	Beta-Cubebene	26.646	0.65	94	26.659	0.57	92			
34	1-dodecanol							26.994	0.12	97
35	Germacrene-d	27.133	3.68	93	27.172	2.56	94	27.129	0.47	93
36	Bicyclogermacrene	27.490	0.29	91	27.503	0.28	93			
37	Gamma-Murolene				27.931	0.12	91			
38	Germacrene D-4-ol	29.461	0.55	93	29.486	0.62	91			
39	Caryophyllene oxide	29.596	0.67	90	29.617	0.69	93	29.606	0.19	92
40	1-pentadecene				29.769	0.23	97	29.767	0.32	97
41	Tau-Cadinol				30.996	0.14	88			
42	Alpha-Cadinol	31.292	0.37	95	31.312	0.4	89			
43	Myristic acid				33.699	0.4	95	33.700	0.5	95
44	1-heptadecene							34.200	0.3	94
45	Neophytadiene	35.067	0.7	95	35.079	0.68	95	35.123	7.17	95
46	Farnesyl acetone				36.612	0.12	90			
47	Palmitic acid	37.725	4.39	96	38.025	8.86	96	37.901	8.06	96
48	Palmitic acid ethyl ester	38.218	3.32	96	38.266	2.52	95			
49	Dodcosanoic acid ethyl ester							38.225	0.71	90
50	Oleic acid				39.642	0.36	88			
51	Squalene							39.683	12.26	95
52	Palmityl alcohol							39.959	0.77	91
53	Stenol	39.942	2.35	95	39.994	2.65	97			
54	Heptadecanoic acid ethyl ester				40.106	0.23	95			
56	Linoleic acid	41.021	9	92	41.389	14.55	92	41.225	15.72	92
55	Phytol	40.367	1.89	93						
57	Linoleic acid ethyl ester	41.392	4.15	92	41.456	2.17	89	41.406	1.15	91
58	Stearic acid				41.644	2.6	94	41.529	2.27	96
59	Stearic acid ethyl ester	41.881	1.22	95	41.925	1.27	92	41.892	0.25	89
60	1-nonadecene	43.525	0.59	93	43.567	1.11	96	43.546	0.33	92
61	Linoleic acid methyl ester				43.976	0.66	90			
62	Arachidic acid	44.844	3.56	90	45.070	2.43	92	44.967	2.61	91

Table 3.8 (Continued).

Peak no.	Other Compounds	A			B			C		
		Ret. Time (min)	Area %	Sim. Index %	Ret. Time (min)	Area %	Sim. Index %	Ret. Time (min)	Area %	Sim. Index %
63	Arachidic acid ethyl ester	45.413	5.92	90	45.503	4.51	88	45.417	1.2	91
64	Tetratriacontane							48.075	5.75	93
65	Tetratetracontane							51.815	7.89	96
	Unidentified Paraffins	-	2.47	-	-	2.29	-	-	9.45	-
	Unidentified compounds		10.39 ⁺			17.48 ⁺			14.46 ⁺	
	TOTAL		100			100			100	

⁺Calculations performed excluding the saturated peaks.

The major component identified in fraction A was carvone. Moreover, this peak was saturated and, therefore, it is likely that carvone represents a large part of the composition of this fraction of the extract. Linalool, dihydrocarveol, palmitic acid, linoleic acid, its ethyl ester and arachidic acid ethyl ester also represent a large part of the constitution of this fraction of the extract.

The major components identified in fraction B were the same, but in different percentages (see Tables 3.7 and 3.8). In this portion, there was a reduction of the importance of oxygenated monoterpenes (carvone, dihydrocarveol and linalool) in terms of percentage, and an increase of the importance of diterpenes (phytol) and fatty acids (linoleic and palmitic acids). Nevertheless, the peak of carvone was still saturated in this fraction, as well as the peak of phytol.

The major components identified in fraction C were neophytadiene, palmitic acid, squalene, linoleic acid, tetratricontane and tetratetracontane. In this fraction, only the peak of phytol remained saturated.

The chemical compositions of the three fractions revealed to be mainly composed of oxygenated monoterpenes (carvone, dihydrocarveol and linalool), diterpenes (neophytadiene and phytol), triterpenes (squalene), fatty acids (palmitic and linoleic acids) and higher molecular weight compounds (tetratricontane and tetratetracontane). It seems that the peaks of oxygenated monoterpenes gradually lose intensity with time, and/or with the introduction of ethanol as co-solvent, and in the peaks of fatty acids and other higher molecular weight compounds the intensity increases.

Zhao et al. (2013) obtained the essential oil of several different geographical populations of *Mentha spicata* by hydrodistillation and carvone was consistently the major compound in the oils, as happened especially in fraction A of the extract obtained by SFE in this work.

Mentha x piperita var. citrata

In the fractions of the extract of *Mentha x piperita var. citrata*, a total of 57 compounds were identified. The results are summarized in Tables 3.9 and 3.10.

Table 3.9 Major extract constituents of *M. piperita var. citrata* determined by GC-MS.

Peak no.	Major Compounds *	A			B			C		
		Ret. Time (min)	Area %	Sim. Index %	Ret. Time (min)	Area %	Sim. Index %	Ret. Time (min)	Area %	Sim. Index %
3	Eucalyptol	14.213	> 4.12	97						
7	Linalool	16.988	> 27.66	96	16.782	> 17.78	95			
20	Linalyl acetate	21.422	> 25.68	92	21.234	> 20.09	93			
52	Phytol							40.446	> 5.07	96
	Other compounds		< 42.54			< 62.13			< 94.93	
	TOTAL		100			100			100	

*Saturated peaks.

Table 3.10 Other extract constituents of *M. piperita var. citrata* determined by GC-MS.

Peak no.	Other Compounds	A			B			C		
		Ret. Time (min)	Area %	Sim. Index %	Ret. Time (min)	Area %	Sim. Index %	Ret. Time (min)	Area %	Sim. Index %
1	Beta-Pinene	12.217	0.23	96						
2	Myrcene	12.758	1.93	96	12.758	0.22	97			
3	Eucalyptol				14.182	1.8	96			
4	Alpha-Pinene	14.373	1.4	96						
5	Beta-Ocimene	14.708	0.96	96						
6	Cis-Linalol oxide	16.077	0.81	92						
7	Linalool							16.538	2.48	97
8	3-Octanol acetate	17.242	0.74	90	16.841	0.28				
9	Camphor	18.060	1.05	97	17.989	0.29	96			
10	Isomenthone	18.304	0.48	96						
11	Lavandulol				18.526	0.21	89			
12	(-)-alpha-Terpineol	18.781	2.02	90						
13	Menthol				18.976	0.73	97	18.949	0.6	97
14	4-terpineol	19.050	0.84	94						
15	1-dodecene				19.279	0.22	93	19.273	0.23	96
16	(+)-alpha-Terpineol	19.621	3.6	96	19.520	1.38	93			
17	Linalyl formate	19.943	2.39	95	19.912	0.61	94			
18	Beta-Citronellol				20.583	0.21	94			
19	Pulegone	20.757	2.12	95	20.720	0.58	96			
20	Linalyl acetate							21.010	3.96	96
21	Citronellyl acetate	23.758	0.44	95	23.747	0.16	96			
22	Neryl acetate	24.004	0.64	96	23.990	0.3	95			
23	Geranyl acetate	24.531	0.83	94	24.517	0.27	97			
24	Beta-Bourbonene	24.662	0.36	96						
25	Beta-Elemene	24.815	0.77	94						

Table 3.10. (Continued).

Peak no.	Other Compounds	A			B			C		
		Ret. Time (min)	Area %	Sim. Index %	Ret. Time (min)	Area %	Sim. Index %	Ret. Time (min)	Area %	Sim. Index %
26	1-tetradecene				24.854	0.82	96			
27	1-tridecene							24.856	0.53	97
28	Jasmone	24.967	0.29	94						
29	Tridecane							25.059	0.1	95
30	Caryophyllene	25.634	4.78	95	25.605	2.34	95	25.588	0.15	94
31	Alpha-cubebene	26.269	1.51	88	26.260	0.68	89			
32	Beta-Farnesene	26.422	1.17	92	26.407	0.53	93			
33	Alpha-Humulene	26.518	0.62	96	26.508	0.26	96			
34	Beta-Cubebene	26.688	1.38	93	26.675	0.75	92			
35	Germacrene-D	27.205	5.69	94	27.175	3.19	93	27.150	0.22	93
36	Bicyclogermacrene	27.530	1.07	94	27.519	0.5	94			
37	Alpha-Murolene	28.517	0.24	91						
38	Caryophyllene oxide	29.625	0.35	92	29.620	0.25	93			
39	1-pentadecene				29.785	0.38	97	29.791	0.62	97
40	Epiglobulol	29.936	1.73	92	29.936	1.22	91			
41	Alpha-Cadinol	31.325	0.41	90	31.327	0.36	90			
42	Myristic acid	33.650	0.36	96	33.678	0.52	96	33.733	0.57	94
43	Loliolide	33.850	0.24	93						
44	1-heptadecene				34.217	0.32	93	34.224	0.5	96
45	Neophytadiene	35.093	0.52	96	35.102	1.65	95	35.174	10.41	95
46	Hexahydrofarnesyl acetone	35.220	0.36	95	35.223	0.61	92			
47	Pentadecanoic acid							35.756	0.29	92
48	Palmitic acid	37.955	11.56	95	37.982	12.45	95	37.950	9.09	95
49	Palmitic acid ethyl ester	38.246	0.74	96	38.247	0.75	93			
50	Oleic acid	39.617	0.29	90						
51	Squalene				39.742	9.93	95	39.742	9.2	95
52	Phytol	40.413	3.13	96	40.427	4.16	96			
53	Linoleic acid	41.258	17.01	93	41.283	17.03	92	41.238	13.22	92
54	Linoleic acid ethyl ester	41.425	1.11	89	41.433	0.94	89	41.434	0.68	91
55	Stearic acid	41.558	2.34	96	41.567	2.23	95	41.552	2.11	95
56	Tetratricontane							48.317	9.03	96
57	Nonacosane	54.808	1.75	96	54.868	5.84	95	54.889	5.97	93
	Unidentified Paraffins	-	6.8	-	-	7.7	-	-	8.23	-
	Unidentified compounds		12.94 ⁺			17.33 ⁺			21.81 ⁺	
	TOTAL		100			100			100	

⁺Calculations performed excluding the saturated peaks.

The major components identified in fraction A were eucalyptol, linalool, linalyl acetate, caryophyllene, palmitic acid and linoleic acid. The peaks that correspond to linalool, linalyl acetate and eucalyptol revealed to be saturated in this fraction.

In fraction B, linalool, linalyl acetate, palmitic acid, squalene, linoleic acid and nonacosane were the main compounds identified. Both linalyl acetate and linalool peaks remained saturated.

The major components identified in fraction C were neophytadiene, palmitic acid, squalene, linoleic acid, tetratricontane and nonacosane. In this fraction, phytol also had an intense peak and was the only one which remained saturated.

The chemical compositions of the three fractions revealed to be mainly composed of oxygenated monoterpenes (linalool, linalyl acetate and eucalyptol), sesquiterpenes (caryophyllene), diterpenes (neophytadiene and phytol), triterpenes (squalene), fatty acids (palmitic and linoleic acids) and higher molecular weight compounds (nonacosane and tetratetracontane). Just as with the *Mentha spicata* extract, it seems that the oxygenated monoterpenes and sesquiterpenes lose importance with time and/or with the introduction of ethanol as co-solvent, and diterpenes, triterpenes, fatty acids and other higher molecular weight compounds gain importance.

Initially, due to the physical similarities of the plants, it was thought that *Mentha x piperita var. citrata* was *Mentha x piperita*. However, Kumar et al. (2012) compared *Mentha x piperita* to *Mentha x piperita var. citrata*, which is one of its varieties, and found that the commercial essential oil of *Mentha x piperita* was rich in menthol and menthone. As can be seen in Tables 3.9 and 3.10, there are only traces of menthol, and menthone was not identified at all. However, according to the same authors, the essential oil of this specific variety of *Mentha x piperita*, *Mentha x piperita var. citrata*, revealed to be rich in linalyl acetate and linalool, which correspond to the profile obtained by GC-MS analysis. Thus, it is likely that *Mentha x piperita var. citrata* was the variety studied and analyzed in this report.

As hybridization is frequent in the genus *Mentha* both in wild populations and in cultivation, to future work, it would be important to identify more carefully the matrices, at least the taxonomically complex genus. Voirin and Faure (1999) had suggested studying the external lipophilic methylated flavonoids, but GC-MS does not seem a bad alternative either.

Mentha pulegium

A total of 45 compounds were identified in the fractions of the extract of *Mentha spicata*. The results are summarized in Tables 3.11 and 3.12, and the main compounds are highlighted in bold.

Table 3.11 Major extract constituents of *M. pulegium* determined by GC-MS.

Peak no.	Major Compounds *	A			B			C		
		Ret. Time (min)	Area %	Sim. Index %	Ret. Time (min)	Area %	Sim. Index %	Ret. Time (min)	Area %	Sim. Index %
5	Menthone	18.339	> 9.45	95						
14	Pulegone	21.088	> 25.06	95						
17	Menthyl acetate	21.679	> 2.26	96						
	Other compounds		< 63.23			100			100	
	TOTAL		100			100			100	

*Saturated peaks.

Table 3.12 Other extract constituents of *M. pulegium* determined by GC-MS.

Peak no.	Other Compounds	A			B			C		
		Ret. Time (min)	Area %	Sim. Index %	Ret. Time (min)	Area %	Sim. Index %	Ret. Time (min)	Area %	Sim. Index %
1	3-octanol	13.108	1.25	97	13.125	0.12	97			
2	Linalool	16.551	4.57	96	16.497	0.54	96	16.505	0.2	96
3	3-Octanol acetate	17.094	0.62	92						
4	Camphor	17.936	0.63	96	17.936	0.1	96			
5	Menthone				18.234	4.05	95	18.225	1.42	95
6	Menthofurane	18.467	0.24	95						
7	Isomenthone	18.525	2.38	96	18.493	0.4	95	18.500	0.15	89
8	Isomenthol	18.722	6.14	97	18.696	2.67	97	18.692	0.61	94
9	Isopulegone				18.838	0.45	93	18.954	0.5	94
10	Menthol	18.883	10.44	93	18.974	0.23	90			
11	4-terpineol	19.006	0.64	92						
12	(Z)-3-tetradecene				19.262	0.14	89			
13	Alpha-Terpineol	19.733	0.33	92						
14	Pulegone				20.804	16.12	95	20.742	5.9	96
15	Carvone				20.895	0.2	93			
16	Linalyl acetate				20.972	0.23	96			
17	Menthyl acetate				21.626	1.12	95	21.631	0.35	94
18	Isomenthyl acetate	22.555	0.85	90	22.539	0.16	93			
19	Piperitone	23.547	1.77	89	23.516	0.48	88			
20	Caryophyllene	25.584	0.87	95	25.577	0.32	94			
21	Alpha-humulene	26.509	1.56	96	26.499	0.67	96			
22	Hexadecane				26.567	0.1	91			
23	Mint furanone	27.659	0.51	90	27.642	0.2	88			
24	Dodecanoic acid							29.340	0.19	88
25	Isovanillic acid							29.525	0.18	88
26	Caryophyllene oxide	29.622	0.92	93	29.617	0.31	93	29.625	0.12	89
27	Myristyl aldehyde							32.594	0.27	93
28	Myristic acid	33.685	0.7	95	33.694	0.55	95	33.754	0.67	93
29	Neophytadiene	35.085	0.59	96	35.097	2.56	96	35.120	6.42	96
30	Hexahydrofarnesyl acetone				35.218	1.03	88			

Table 3.12 (Continued).

Peak no.	Compound	A			B			C		
		Ret. Time (min)	Area %	Sim. Index %	Ret. Time (min)	Area %	Sim. Index %	Ret. Time (min)	Area %	Sim. Index %
31	3.7.11.15-Tetramethyl-2-hexadecen-1-ol							35.608	1.55	93
32	Pentadecanoic acid							35.787	0.15	93
33	Palmitic acid	37.933	9.17	95	37.846	6.56	93	37.876	5.95	94
34	Palmitic acid ethyl ester	38.233	0.42	95	38.233	0.33	92			
35	Behenic acid ethyl ester							38.242	0.32	88
36	Margaric acid				39.618	0.11	92	39.660	0.11	94
37	Phytol	40.392	1.2	95	40.397	0.97	95	40.412	1.54	95
38	Linoleic acid	41.257	14.4	90	41.150	13.6	92	41.186	13.49	93
39	Linoleic acid chloride				41.299	1.12	92	41.320	1.51	92
40	Linoleic acid ethyl ester	41.416	1.01	89	41.414	1	93	41.422	0.91	92
41	Stearic acid	41.562	2.34	96	41.499	2.23	94	41.531	2.33	95
42	Stearic acid ethyl ester				41.900	0.1	88			
43	Tetratricontane				48.317	16.15	96	48.333	16.29	95
44	Tetracontane							52.502	19.31	96
45	Nonacosane	54.858	3.83	96	54.844	4.92	95	54.825	0.73	93
46	Unidentified Paraffins	-	2.97	-	-	6.14	-	-	6.24	-
	Unidentified compounds		29.65 ⁺			14.02 ⁺			12.59 ⁺	
	TOTAL		100			100			100	

⁺Calculations performed excluding the saturated peaks.

The major components identified in fraction A were linalool, menthone, isomenthol, menthol, pulegone, palmitic acid and linoleic acid. The peaks that correspond to pulegone, menthone and methyl acetate revealed to be saturated in this fraction.

In fraction B, pulegone, palmitic acid, linoleic acid, tetratricontane and nonacosane were the main compounds identified. In this fraction, there were no saturated peaks.

The major components identified in fraction C were pulegone, neophytadiene, palmitic acid, linoleic acid, tetratricontane and tetracontane. As in fraction B, there were no saturated peaks.

The chemical compositions of the three fractions revealed to be mainly composed of oxygenated monoterpenes (pulegone, menthol, menthone, isomenthol and linalool), diterpenes (neophytadiene), fatty acids (palmitic and linoleic acids) and higher molecular weight compounds (nonacosane, tetracontane and tetratricontane). Just as with the *Mentha spicata* and the *Mentha x piperita* var. *citrata* extracts, it seems that the oxygenated monoterpenes vanish with time and/or with the introduction of ethanol as co-solvent, and diterpenes, fatty acids and other higher molecular weight compounds appear.

Teixeira et al. (2012) and Aghel et al. (2004), which obtained *Mentha pulegium* essential oil by hydrodistillation and SFE respectively, reported that the major compounds

present in the oil were pulegone and menthone, which correspond to the major compounds identified especially in fraction A.

By looking to the chromatograms in Appendix B, the peaks seem to lose intensity with time of extraction and/or with the addition of co-solvent and, in general, in fraction C, the peaks with higher intensity are shifted to higher retention times. The peaks with higher retention times correspond to the less volatile compounds that are present in the extracts including saturated hydrocarbons (paraffins), which are not of much interest to this work. Hence, the last 1.5 hours of extraction does not appear to be necessary.

It is important to refer that the three fractions of the extract of *Lavandula angustifolia* were injected again after 3 months (see chromatograms in Appendix B) and the chromatogram obtained was a bit different: the peaks were less intense and poorly resolved. This might be due to degradation of the extract and/or due to a lower efficiency of the column. However with other samples this effect was not noticed so there may be a stability problem with the extracts. Furthermore, seems to have been formation of some other compounds which did not exist in the fresh extracts. In future work it would be important to find a way to ensure the stability of the extracts, since the degraded extract will probably not demonstrate the same bioactivities than the ones presented by the fresh extract.

3.3. Evaluation of the antioxidant activity of the natural extracts using chemical assays

In order to evaluate the antioxidant activities of the natural extracts obtained by supercritical fluid extraction, three different assays were performed, namely ORAC, HORAC and HOSC. These three assays are complementary, since they measure different capacities towards different free radicals.

As explained in chapter 2, the ORAC assay measures the peroxy radicals scavenging capacity of the antioxidant species. In its turn, HORAC assay measures the ability of the samples to prevent the hydroxyl radicals from being generated. Finally, the HOSC assay measures the antioxidant species capacity of scavenging hydroxyl radicals.

The results obtained for each extract in each assay were quite different. ORAC, HORAC and HOSC values of the aromatic plants extracts varied from 139 to 514 $\mu\text{mol TE/g}$ extract, 23 to 1580 $\mu\text{mol CAE/g}$ and 152 to 1381 $\mu\text{mol TE/g}$, respectively. The results obtained for each sample in each assay are shown in Table 3.13.

Table 3.13 Antioxidant activity of the fractions of the natural extracts obtained by SFE.

Sample ID	ORAC ($\mu\text{mol TE/g extract}$)			HORAC ($\mu\text{mol CAE/g extract}$)			HOSC ($\mu\text{mol TE/g extract}$)		
	A	B	C	A	B	C	A	B	C
<i>L. angustifolia</i>	438.0 \pm 45.0	456.4 \pm 46.0	240.8 \pm 23.2	195.6 \pm 25.7	239.6 \pm 24.8	263.8 \pm 40.0	1139.4 \pm 135.3	866.2 \pm 82.5	449.8 \pm 60.9
<i>L. stoechas</i>	138.7 \pm 17.8	138.7 \pm 18.1	152.1 \pm 19.5	22.9 \pm 3.4	30.6 \pm 4.2	123.7 \pm 17.7	203.7 \pm 18.5	151.9 \pm 19.3	159.4 \pm 19.5
<i>M. spicata</i>	305.3 \pm 43.0	372.8 \pm 34.1	360.5 \pm 33.8	213.4 \pm 31.1	188.0 \pm 20.2	388.9 \pm 62.5	549.4 \pm 42.1	441.8 \pm 42.9	475.5 \pm 58.1
<i>M. piperita</i> var. <i>citrata</i>	415.9 \pm 49.7	513.7 \pm 40.2	258.7 \pm 34.0	1036.6 \pm 155.2	1580.0 \pm 252.0	765.0 \pm 114.8	1380.5 \pm 125.2	902.4 \pm 111.7	445.8 \pm 66.4
<i>M. pulegium</i>	193.6 \pm 23.5	143.6 \pm 12.2	355.0 \pm 34.9	202.9 \pm 33.9	110.4 \pm 14.5	230.5 \pm 54.06	340.2 \pm 34.3	450.7 \pm 58.1	357.9 \pm 57.1

A graphical representation of the values presented in Table 3.13 can be seen in Figure 3.2.

The extract of *Mentha x piperita* var. *citrata* presented the most promising results in all three assays. Still, the *Lavandula angustifolia* extract also exhibited good results on both assays that measured the ability of the samples in scavenging harmful reactive oxygen species (ORAC and HOSC). The lowest results were presented by *Lavandula stoechas* in all three assays. The extracts of *Mentha spicata* and *Mentha pulegium* presented moderate antioxidant capacities in the three assays, when compared to the remaining extracts.

These data suggests that the fraction B of *Mentha x piperita* var. *citrata* extract exhibited the most promising antioxidant activity on ORAC and HORAC, while the fraction A presented the highest antioxidant capacity on HOSC assay. This might mean that the effect observed is not always triggered by the same antioxidant species. In other words, different antioxidant species present different capacities towards different free radicals. It is likely that the species responsible for the effect presented on HOSC assay are mainly the constituents of its essential oil, since the best effect was shown by fraction A, which corresponds to the extraction with supercritical CO₂.

Regarding to *Lavandula angustifolia* extract, the effect of both A and B fractions seemed to be quite similar on ORAC assay. However, on HOSC assay, there was a noticeable difference between those two fractions. The lowest result for this extract was presented on HORAC assay.

The antioxidant activity in plants is commonly attributed to phenolic compounds, which are broadly distributed in the plant kingdom and are the most abundant secondary metabolites of plants. (Zitka et al., 2011) However, as studied by other authors like El-Massry et al. (2002) and Bagheri et al. (2014), it is possible that extracts rich in nonphenolic compounds also have

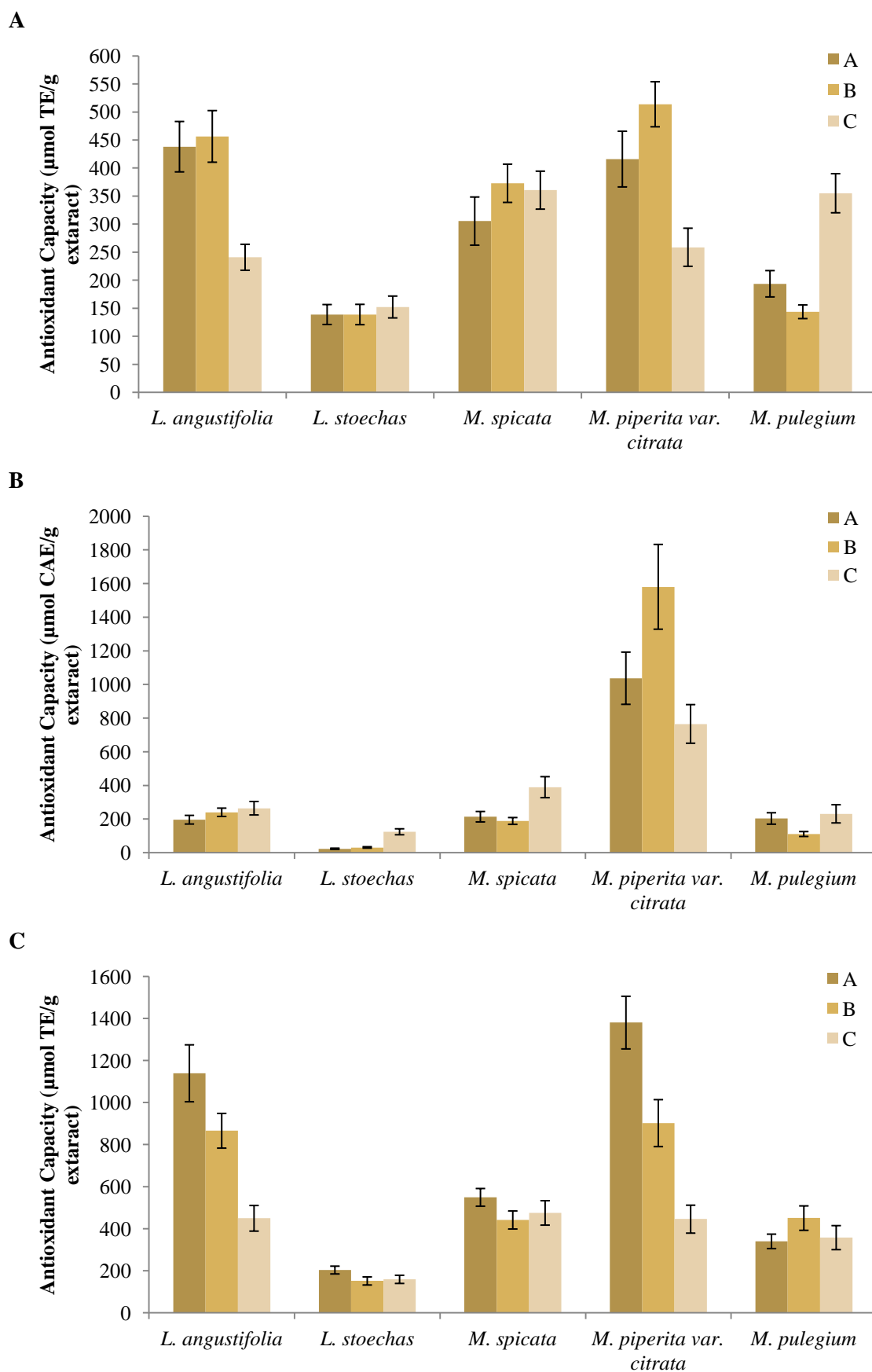

Figure 3.2 Antioxidant capacity of the fractions A, B and C of *Lavandula* and *Mentha* extracts. Legend: A – ORAC assay; B – HORAC assay; C – HOSC assay.

antioxidant potential. Moreover, Ruberto & Baratta (2000) studied the antioxidant activity of 98 typical chemical components of essential oils, showing that some monoterpene hydrocarbons, oxygenated monoterpenes and sesquiterpenes have significant antioxidant effects. According to Richard et al. (2008), some polyunsaturated fatty acids, such as oleic, linoleic or stearic acids, can also act as antioxidants.

As shown in section 3.2., these two species have on their composition high concentrations of similar chemical substances namely linalool, linalyl acetate, eucalyptol, and camphor (at higher concentration in *Lavandula angustifolia* extract). According to the literature, linalool does not present any antioxidant capacity. (Tepe et al., 2007) Moreover, in the study conducted by Ruberto & Baratta (2000) even revealed having a pro-oxidant effect. Among the three remaining compounds, linalyl acetate is the one that presents a higher antioxidant activity, according to Ruberto & Baratta (2000), which may explain the higher antioxidant activity of fraction A showed by the *Mentha x piperita* var. *citrata* extract on HOSC assay, since it is one of its major constituents. It is also shown in section 3.2., that the fraction B contains squalene in its composition. The results obtained by Dessì et al. (2002) suggest that squalene acts mainly as a peroxy radical scavenger, which may explain the higher antioxidant capacity of fraction B on ORAC assay. To my knowledge, there are no studies of the ability of squalene in preventing the hydroxyl radicals from being generated. However, it is possible that squalene also acts in the effect shown by the fraction B in HORAC assay.

Better results shown for fractions B might also be explained by an increase of the polyphenols content in the extract, by adding ethanol as co-solvent. However, this is merely a hypothesis, since no assays were performed in order to evaluate the polyphenols content, due to the lipophilicity of the extract and the aqueous systems of the assays. To future works it would be interesting to explore these results.

The *Lavandula angustifolia* extract also have in its composition 4-terpineol and lavandulol, which are oxygenated monoterpenes with recognized moderate antioxidant activity, when compared to α -tocopherol. (Ruberto & Baratta, 2000) This compound might eventually compensate the high content of the extract in camphor, which is also an oxygenated monoterpene, but has demonstrated poor antioxidant capacity. (Ruberto & Baratta, 2000)

In this case, the antioxidant capacity of the samples would be considered to be concentration-dependent. However, according to several authors, such as Hussain et al. (2008), Tepe et al. (2004) and Vardar-Ünlü et al. (2003), it is also possible that there is a synergistic interaction between the extract constituents. Thus, the entire extract can show a greater antioxidant capacity than the individual components itself. This is probably what is happening, since, the antioxidant activity of pure squalene assayed by the L-ORAC method, exhibited an antioxidant activity of 0.74 $\mu\text{mol TE/g}$ (Tikekar et al., 2008), which is a very low value when

compared to the extracts results obtained in ORAC assay. This is just an example, but other cases should be explored and considered for a future work.

With respect to the extracts of *Mentha spicata* and *Mentha pulegium*, they presented moderate antioxidant capacities in all three assays. The main constituents of these extracts are carvone and pulegone, respectively, which also have exhibited moderate antioxidant activities. (Ruberto & Baratta, 2000) Again, it is possible that the antioxidant activity is due to a synergistic interaction between these and other compounds.

Finally, regarding to *Lavandula stoechas* extract, its main constituents, such as camphor, linalool, fenchone and eucalyptol, have poor antioxidant activities, according to Ruberto & Baratta (2000), and that might be the reason for the low results presented in all three assays.

Overall, the natural extracts exhibited better antioxidant capacity results on HOSC assay, suggesting that the natural extracts are more promising as free radical scavengers, being constituted mainly by radical chain breaking antioxidants, than by preventive antioxidants, at least with respect to the hydroxyl radical generation prevention.

Again, as can be seen in section 3.2., the extracts are a very complex mixture of compounds with different functional groups and, consequently, present different chemical behaviors. Thus, it is important to highlight that, given the chemical complexity of the extracts, it is possible to obtain a wide range of different results, depending on the antioxidant test applied. This difference is explicit if we compare the lower results obtained in HORAC assay with the two other tests (except for the extract of *Mentha x piperita* var. *citrata* which presented a lower result on ORAC assay).

To my knowledge, there are no works in which supercritical fluid extracts of these particular species are tested for these three specific assays.

Though ethanol had been added as a co-solvent, the percentage added was quite small to achieve a high increase in the polarity of the solvent mixture. Hence, the extract obtained by SFE was mainly lipophilic. Therefore, all of the methods that were performed were not suitable for lipophilic antioxidants, since they are conducted in aqueous systems. Thus, a fourth method was performed in order to understand the importance of the lipophilic antioxidants in the extract.

To do so, a random sample, in this case the fraction A of the *Mentha spicata* extract, was properly diluted in mixtures of acetone and water (50:50) with 4%, 7% and 10% of HP- β -CD. Cyclodextrins are cyclic (α -1,4)-linked oligosaccharides of α -D-glucopyranose containing a relatively hydrophobic (fatlike) central cavity and hydrophilic (waterlike) outer surface. This property of CD has made it a vehicle for enhancing the solubility of fat soluble compounds in an

aqueous environment. (Huang et al., 2002) Specifically, HP- β -CD, is a hydroxyalkylated CD derivative and is widely used to increase the solubility. (Hsu et al., 2013)

The results are presented in Figure 3.3.

It is visible that HP- β -CD solvent as increased about seven times the antioxidant activity of the sample of *Mentha spicata* extract in the results obtained with the 7% of HP- β -CD solvent, comparing with the ORAC assay. In this sample, for the three solvents that were used (with different percentages of HP- β -CD), the results seem to be identical, and differences appear to be contained in error.

However, to understand how would be the behavior of a non lipophilic antioxidant, the same assay was carried out using ascorbic acid, a widely known antioxidant. In this case, the results were quite strange since there was not a dose-dependent effect (ascorbic acid in 7% of HP- β -CD solvent presented a lower result), and the differences between the results for each solvent concentration, were not contained in error. This is a phenomenon that is hard to explain. Might have been just an error, but there was no time to correct it or to explore and implement the method. Still, these were very interesting results, which should be further explored in future works.

A

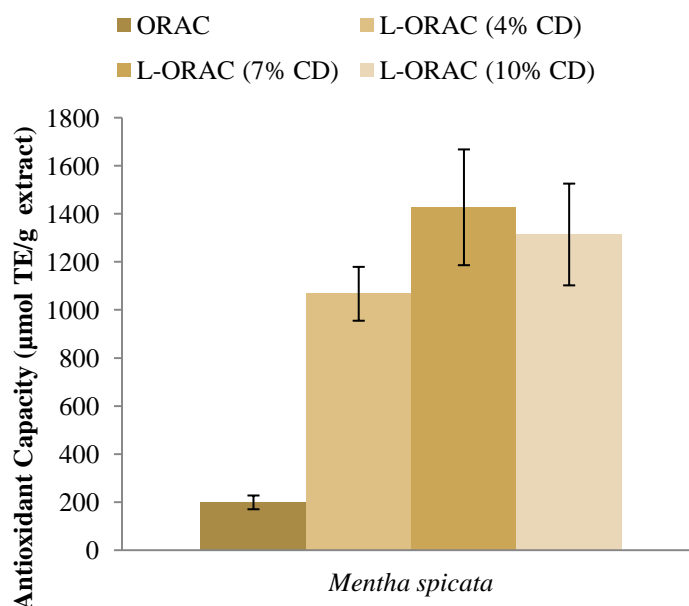

B

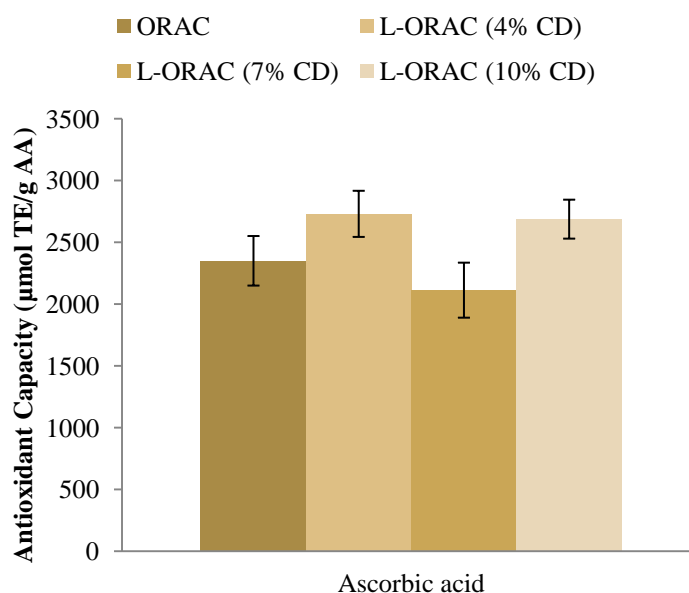

Figure 3.3 Hydrophilic and lipophilic antioxidant capacities tested by ORAC and L-ORAC assays. Legend: A – fraction A of *Mentha spicata* extract; B – ascorbic acid.

3.4. Evaluation of the antiproliferative effect of the natural extracts in HT-29 cells

In order to examine the anticancer potential of the extracts obtained by SFE, antiproliferative assays were conducted in human colorectal adenocarcinoma cells (HT-29). The cells were exposed to the natural extracts for 24h and the percentage of viable cells was evaluated using MTT assay.

The results obtained for the three fractions (A, B and C) of the natural extracts are presented in Figure 3.4 as dose-response curves.

The results showed that the fractions A and B of the extract of *Lavandula angustifolia* along with the extract of *Lavandula stoechas* presented the highest antiproliferative activities on human colorectal cancer cells. The same fractions of the extract of *Mentha spicata* also exhibited good results. The lowest antiproliferative capacities were presented by the extract of *Mentha x piperita* var. *citrata* followed by the extract of *Mentha pulegium*.

The concentrations of extract required to decrease 50% of the cell viability (EC50) were also determined and are shown in Table 3.14.

Table 3.14 Concentrations of SFE natural extract required to decrease 50% of the cell viability (EC50), after an incubation period of 24h. (Data are means \pm SD (n=2)).

Sample ID	EC50 (mg extract/mL)		
	A	B	C
<i>L. angustifolia</i>	0.112 \pm 0.011	0.095 \pm 0.017	0.166 \pm 0.011
<i>L. stoechas</i>	0.124 \pm 0.020	0.094 \pm 0.018	0.235 \pm 0.031
<i>M. spicata</i>	0.126 \pm 0.012	0.087 \pm 0.015	0.269*
<i>M. piperita</i> var. <i>citrata</i>	0.339 \pm 0.071	0.152 \pm 0.020	0.283 \pm 0.037
<i>M. pulegium</i>	0.225 \pm 0.037	0.184 \pm 0.095	0.304 \pm 0.049

*For this fraction of the extract of *Mentha spicata* it was only possible to calculate the EC50 value with n=1.

A graphical representation of the values presented in Table 3.14 can be seen in Figure 3.5.

Moreover, it is important to emphasize that, at this concentration, the SFE extracts did not exhibit cytotoxicity in Caco-2 cells (data not shown), which are a good model of the human intestinal barrier.

It is clear that the extracts of the species of the genus *Lavandula* were more effective in inhibiting colorectal cancer cells than the extracts of the species of the genus *Mentha*. In other words, and looking to EC50 values presented in Table 3.14, a lesser amount of *Lavandula* extracts is needed to inhibit half of the cell viability. In addition, it seems that the more promising results are presented by fraction B. Better results shown for fractions B might eventually be explained by an increase of the polyphenols content in the extract, by adding ethanol as co-solvent. Again, this is merely a hypothesis, since no assays were performed in order to evaluate the polyphenols content.

Surprisingly, the fractions A and B of the extract obtained from *Lavandula stoechas*, which had showed the lowest antioxidant capacity, were the second fractions most effective in inhibiting HT-29 cells growth. These results suggest that there are some compounds that are present in the extract that contribute to this effect, but do not have antioxidant properties.

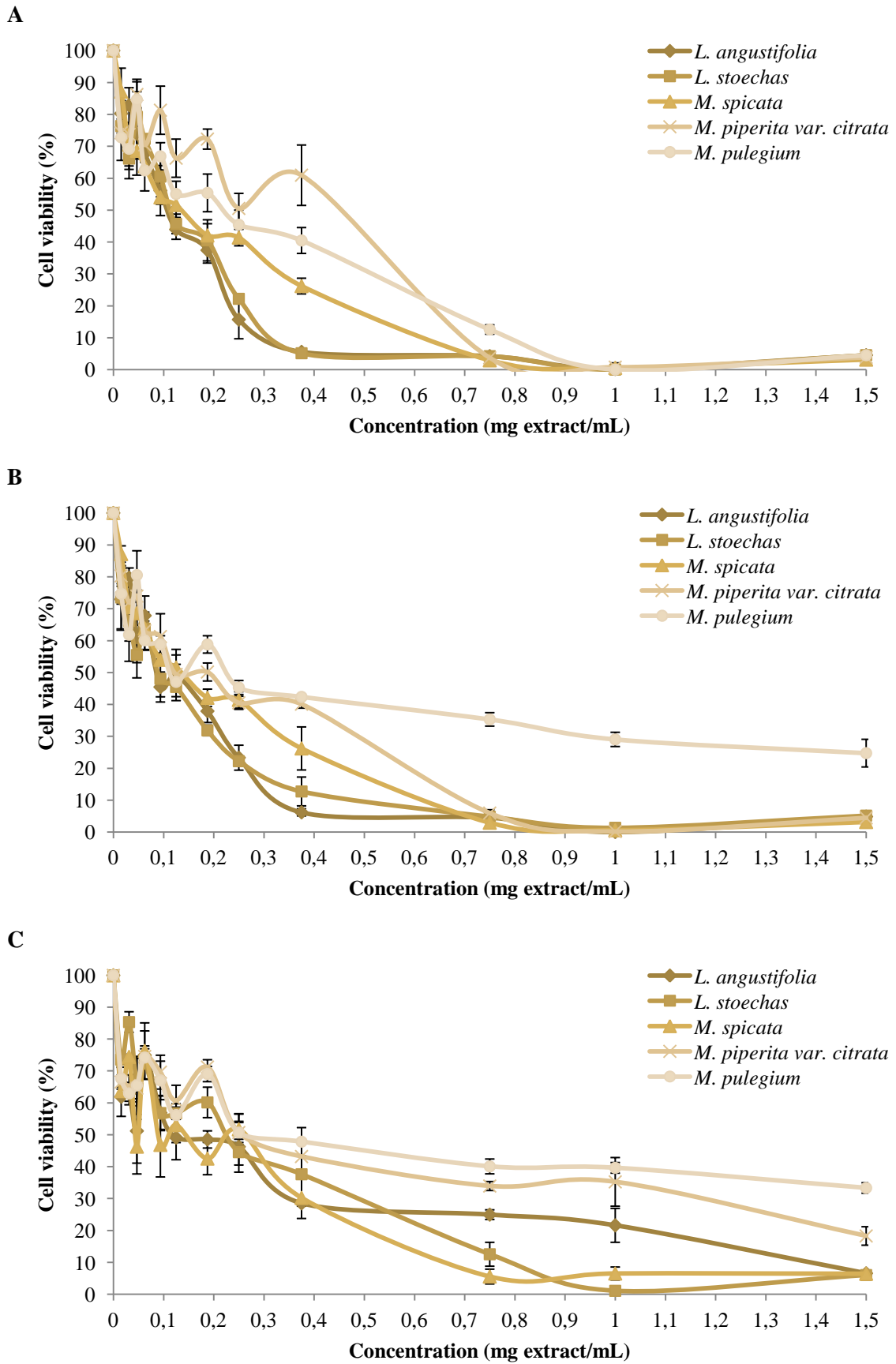

Figure 3.4 Antiproliferative effect of the fractions A, B and C of *Lavandula* and *Mentha* extracts on HT-29 human colorectal adenocarcinoma cells (n=2).

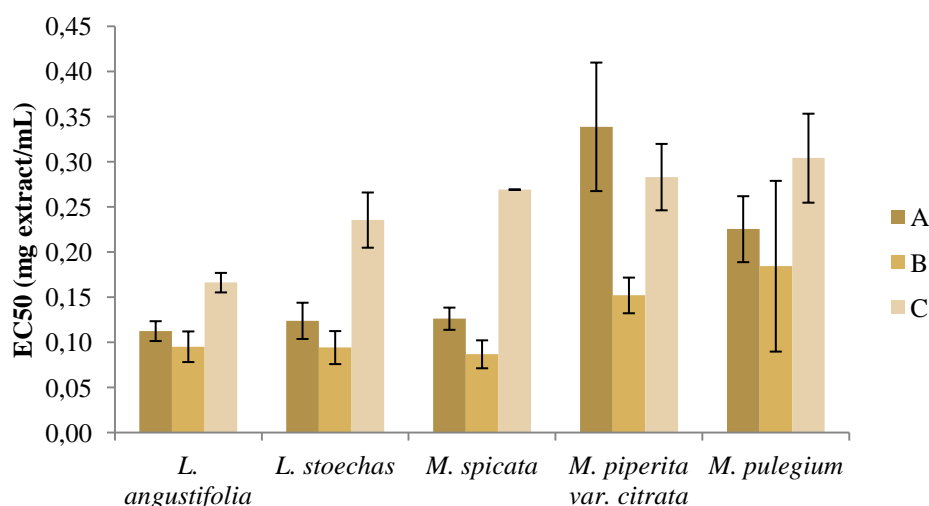

Figure 3.5 Concentrations of the fractions A, B and C of the natural extracts required to decrease 50% of the cell viability (EC50), after an incubation period of 24h. (Data are means \pm SD (n=2)).

It is also noticeable that the fraction C presented the worst results for all the natural extracts. Additionally, it appears to be an interference of some compound or a mixture of compounds present in fraction C with MTT method. In fact, and especially in the *Mentha* extracts, the fractions C are composed by high molecular weight compounds such as paraffins, which clearly did not presented the expected effect. Again, it seems that the last 1.5 hours of extraction did not produce any further benefits.

To my knowledge, this is the first time that extracts of this species of the *Lamiaceae* family are tested in HT-29 cells and, in this work, the anticancer effect of each compound present in the extracts was not evaluated against the cell line. Therefore, at this stage, it is not possible to conclude with certainty about which compounds are responsible for the observed activity. However, it is possible to hypothesize, based on the data available in the literature for specific compounds that are present in the extracts.

For instance, all the major compounds of the fractions A and B of the extracts of *Lavandula angustifolia*, *Lavandula stoechas* and *Mentha spicata* were reported as having some kind of antiproliferative effect. Among others, Tatman et al. 2002, studied the effect of several volatile isoprenoids on murine B16 melanoma and HL-60 leukemia cells. Among them linalool, fenchone and α -terpineol; camphor, caryophyllene oxide, 4-terpineol and eucalyptol showed cytotoxic activity against HL-60 leukemia cells according to Nibret and Wink (2010); Hayashi et al. (1992) and Ip et al. (1999) studied the anti-hepatic and anti-mammary cancer effects, respectively, of linoleic acid; carvone effect against P-815 (mastocytoma), K-562 (chronic myelogenous leukemia) and CEM (acute lymphocytic leukemia) tumor cell lines was also studied by Jaafari et al. (2012).

However, most of these compounds are also present in the extract of *Mentha x piperita var. citrata*, for example, which revealed a lower toxicity to HT-29 cells. This might suggest

that the activity is not confined to one specific compound, but occurs due to synergies between compounds. In fact, according to Itani et al. (2008), three sage bioactive compounds, namely α -terpineol, linalyl acetate and camphor, synergise to induce cell cycle arrest and apoptosis, mainly via mitochondrial damage (cytochrome c release), caspase activation, and poly(ADP-ribose)-polymerase cleavage, in human colorectal cancer cells. That and other synergies between compounds might be what is causing the cytotoxic effect of the extracts in HT-29 human colorectal adenocarcinoma cells.

4. Conclusions

In this work, two species of the genus *Lavandula* (*Lavandula angustifolia* and *Lavandula stoechas*) and three other species of the genus *Mentha* (*Mentha spicata*, *Mentha x piperita* var. *citrata* and *Mentha pulegium*) were submitted to supercritical fluid extraction, in order to isolate phytochemical rich fractions with potential anticancer activity.

All extractions were performed at 50°C and 250 bar in a two step methodology. A first step with supercritical CO₂ for 60 minutes, followed by a second step with a mixture of CO₂ and ethanol (90:10 v/v), for 180 minutes. By applying these conditions, it was possible to obtain different fractions of extracts rich in terpenes and fatty acids, which are known biologically active compounds. After TLC analysis, the similar fractions were combined into 3 different samples: fraction A, which corresponded to the fractions of the extract obtained in the first step of SFE with supercritical CO₂ during 60 minutes; fraction B, which corresponded to the fractions of the extract obtained in the first 90 minutes of the second step of extraction with a mixture of CO₂ and ethanol (90:10 v/v); and fraction C, which corresponded to the fractions of the extract obtained in the last 90 minutes of the second step of extraction. By using these different fractions of the SFE, it was possible to obtain samples with different compositions, and consequently, different antioxidant and antiproliferative activities.

Among the fifteen fractions of the five extracts that were analyzed, both samples A and B of the extracts of *Lavandula angustifolia*, *Lavandula stoechas* and *Mentha spicata* have demonstrated a powerful anticancer activity. Even so, the fraction B of each extract revealed to be the most effective in inhibiting colorectal cancer cell growth. The biological activities were correlated with the phytochemical composition of each fraction, and their major terpenes and fatty acids were pointed out as being the main responsible for the anticancer and the antioxidant effects. Terpenes like linalool, camphor, fenchone, eucalyptol, carvone, linalyl acetate, and squalene, among others and fatty acids, such as linoleic acid, might be responsible for those biological effects. However, the synergistic effects between several compounds were also pointed as a possibility. Moreover, the introduction of a small quantity of ethanol as co-solvent (10% in volume) has enhanced the antiproliferative effect of the extracts, possibly due to the promotion of the extraction of more polar compounds, such as polyphenols. The sample C of all five extracts, presented the lowest results, which might suggest that the last 90 minutes of extraction are dispensable, since they did not produce any further benefits.

Overall, this thesis revealed that supercritical fluid technology is a reliable process to isolate promising anticancer bioactive compounds from natural sources, namely terpenes

(linalool, camphor, fenchone, carvone, etc.) and fatty acids (linoleic acid) from plants of *Lavandula* and *Mentha* species growing in Portugal.

In future work, it would be interesting to explore other conditions of SFE, such as lower densities of CO₂, which are reported to be more suitable to selectively extract terpenes. If the extracts were retested for the studied biological activities, it might give a better idea of the role of the biological effects of terpenes on their own, without the aid of the fatty acids, and vice versa. Perhaps if some of them were in higher concentrations in the extracts, the anticancer effect could be further enhanced. Moreover, it would be important to find a way to optimize the analytical procedures, so that further tests, such as HPLC analysis, L-ORAC assay, among others, could be performed, and the extracts could be fully characterized. In this case, the application of cyclodextrins as solubility enhancers should be explored. Furthermore, some pure components of the most promising extracts should be tested for their anticancer effectiveness, in this particular cell line (HT-29). It would also be important to study the synergies between compounds, to further understand the antiproliferative effect that was observed and the mechanisms which could have led to it. To do so, further fractionate the extracts could help, as well as test extracts with different compositions for their biological activities.

5. References

- Aghel, N., Yamini, Y., Hadjiakhoondi, A., & Pourmortazavi, S. M. (2004). Supercritical carbon dioxide extraction of *Mentha pulegium* L. essential oil. *Talanta*, 62 (2), 407–11.
- ACS, American Cancer Society (2012). Global Cancer Burden to Nearly Double by 2030. Retrieved in January 6, 2014, from <http://www.cancer.org/myacs/newengland/global-cancer-burden-to-double-by-2030>
- ACS, American Cancer Society (2012). What is cancer? Retrieved in January 6, 2014, from <http://www.cancer.org/cancer/cancerbasics/what-is-cancer>
- ACS, American Cancer Society (2014). What is colorectal cancer? Retrieved in January 6, 2014, from <http://www.cancer.org/cancer/colonandrectumcancer/detailedguide/colorectal-cancer-what-is-colorectal-cancer>
- AICR, American Institute for Cancer Research (2013). What Is Cancer? Retrieved in January 6, 2014, from http://www.aicr.org/reduce-your-cancer-risk/tell-me-about/tellmeabout_what_is_cancer.html
- Andlauer, W., & Fu, P. (2002). Nutraceuticals: a piece of history, present status and outlook. *Food Research International*, 35, 171–176.
- Ansari, K., & Goodarznia, I. (2012). Optimization of supercritical carbon dioxide extraction of essential oil from spearmint (*Mentha spicata* L.) leaves by using Taguchi methodology. *The Journal of Supercritical Fluids*, 67, 123–130.
- Araus, K., Uquiche, E., & del Valle, J. M. (2009). Matrix effects in supercritical CO₂ extraction of essential oils from plant material. *Journal of Food Engineering*, 92 (4), 438–447.
- Azmir, J., Zaidul, I. S. M., Rahman, M. M., Sharif, K. M., Mohamed, A., Sahena, F., Jahurul, M.H.A., Ghafoor, K., Norulaini, N.A.N., & Omar, A. K. M. (2013). Techniques for extraction of bioactive compounds from plant materials: A review. *Journal of Food Engineering*, 117 (4), 426–436.
- Bagheri, H., Abdul Manap, M. Y. B., & Solati, Z. (2014). Antioxidant activity of *Piper nigrum* L. essential oil extracted by supercritical CO₂ extraction and hydro-distillation. *Talanta*, 121, 220–228.
- Bardon, S., Foussard, V., Fournel, S., & Loubat, A. (2002). Monoterpenes inhibit proliferation of human colon cancer cells by modulating cell cycle-related protein expression. *Cancer Letters*, 181 (2), 187–94.
- Barton, P., Hughes, R. E., M. T., & Hussein, M. M. (1992). Supercritical Carbon Dioxide Extraction of Peppermint and Spearmint. *The Journal of Supercritical Fluids*, 5, 157–162.
- Bernal, J., Mendiola, J. a, Ibáñez, E., & Cifuentes, A. (2011). Advanced analysis of nutraceuticals. *Journal of Pharmaceutical and Biomedical Analysis*, 55 (4), 758–74.
- Bimakr, M., Rahman, R. A., Taip, F. S., Ganjloo, A., Salleh, L. M., Selamat, J., Hamid, A., Zaidul, I. S. M. (2011). Comparison of different extraction methods for the extraction of major

bioactive flavonoid compounds from spearmint (*Mentha spicata* L.) leaves. *Food and Bioproducts Processing*, 89 (1), 67–72.

Boivin, D., Lamy, S., Lord-Dufour, S., Jackson, J., Beaulieu, E., Côté, M., Moghrabi, A., Barrette S., Gingras, D., & Béliveau, R. (2009). Antiproliferative and antioxidant activities of common vegetables: A comparative study. *Food Chemistry*, 112 (2), 374–380.

Bolling, B. W., Chen, Y.-Y., Kamil, A. G., & Oliver Chen, C.-Y. (2012). Assay dilution factors confound measures of total antioxidant capacity in polyphenol-rich juices. *Journal of Food Science*, 77(2), H69–75.

Botelho, J. R. S., Medeiros, N. G., Rodrigues, A. M. C., Araújo, M. E., Machado, N. T., Guimarães Santos, A., Santos, I. R., Gomes-Leal, W., Carvalho Júnior, R. N. (2014). Black sesame (*Sesamum indicum* L) seeds extracts by CO₂ supercritical fluid extraction: Isotherms of global yield, kinetics data, total fatty acids, phytosterols and neuroprotective effects. *The Journal of Supercritical Fluids*.

Burke, Y. D., Stark, M. J., Roach, S. L., Sen, S. E., & Crowell, P. L. (1997). Inhibition of pancreatic cancer growth by the dietary isoprenoids farnesol and geraniol. *Lipids*, 32 (2), 151–6.

Cavanagh, H. M. a, & Wilkinson, J. M. (2002). Biological activities of lavender essential oil. *Phytotherapy Research*, 16 (4), 301–8.

Chen, X., Zhang, F., & Yao, L. (2012). Chloroplast DNA molecular characterization and leaf volatiles analysis of mint (*Mentha*; Lamiaceae) populations in China. *Industrial Crops and Products*, 37 (1), 270–274.

Cheung, P. C. K. (1999). Temperature and pressure effects on supercritical carbon dioxide extraction of n-3 fatty acids from red seaweed. *Food Chemistry*, 65, 399–403.

Combest W. L. (2002). U.S. Pharmacist. Alternative Therapies: Lavender. Retrieved in February 5, 2014, from http://legacy.uspharmacist.com/oldformat.asp?url=newlook/files/Alte/lavender.cfm&pub_id=8&article_id=401

Coulson, J. M., & Richardson, J. F. (2002) *Chemical Engineering*. Vol. 2. 5th Edition. Massachusetts: Butterworth-Heinemann.

Croteau, R., Kutchan, T. M., & Lewis, N. G. (2000). Natural Products (Secondary Metabolites). In B. Buchanan, W. Gruissem, & R. Jones (Eds.). *Biochemistry & Molecular Biology of Plants*. (pp.1250–1318). American Society of Plant Physiologists.

Crowell, P. L. (1999). Prevention and Therapy of Cancer by Dietary Monoterpenes. *The Journal of Nutrition*, 775S–78.

Curutchet, A., Dellacassa, E., Ringuet, J. a, Chaves, A. R., & Viña, S. Z. (2014). Nutritional and sensory quality during refrigerated storage of fresh-cut mints (*Mentha × piperita* and *M. spicata*). *Food chemistry*, 143, 231–8.

Da Porto, C., Decorti, D., & Kikic, I. (2009). Flavour compounds of *Lavandula angustifolia* L. to use in food manufacturing: Comparison of three different extraction methods. *Food Chemistry*, 112 (4), 1072–1078.

- Damien Dorman, H. J., Kosar, M., Kahlos, K., Holm, Y., & Hiltunen, R. (2003). Antioxidant Properties and Composition of Aqueous Extracts from *Mentha* Species, Hybrids, Varieties, and Cultivars. *Journal of Agriculture and Food Chemistry*, *51*, 4563–4569.
- Danh, L. T., Triet, N. D. A., Han, L. T. N., Zhao, J., Mammucari, R., & Foster, N. (2012). Antioxidant activity, yield and chemical composition of lavender essential oil extracted by supercritical CO₂. *The Journal of Supercritical Fluids*, *70*, 27–34.
- Desai, A. G., Qazi, G. N., Ganju, R. K., El-Tamer, M., Singh, J., Saxena, A. K., Bedi, Y. S., Taneja, S. C., Bhat, H. K. (2008). Medicinal plants and cancer chemoprevention. *Current Drug Metabolism*, *9* (7), 581–591.
- Dessi, M. A., Deiana, M., Day, B. W., Rosa, A., Banni, S., & Corongiu F. P. (2002). Oxidative stability of polyunsaturated fatty acids: effect of squalene. *Eur. J. Lipid Sci. Technol.*, *104*, 506–512.
- Dillard, C. J., & German, J. B. (2000). Review Phytochemicals: nutraceuticals and human health, *Journal of Science of Food and Agriculture*, *80*, 174–1756.
- Durante, M., Lenucci, M. S., D'Amico, L., Piro, G., & Mita, G. (2014). Effect of drying and co-matrix addition on the yield and quality of supercritical CO₂ extracted pumpkin (*Cucurbita moschata* Duch.) oil. *Food Chemistry*, *148*, 314–20.
- El-Massry, K. F., El-Ghorab, A. H., & Farouk, A. (2002). Antioxidant activity and volatile components of Egyptian *Artemisia judaica* L.. *Food Chemistry*, *79*, 331–336.
- Erhan, M. K., Bölükbaşı, Ş. C., & Ürüşan, H. (2012). Biological activities of pennyroyal (*Mentha pulegium* L.) in broilers. *Livestock Science*, *146* (2-3), 189–192.
- Espín, J. C., García-Conesa, M. T., & Tomás-Barberán, F. A. (2007). Nutraceuticals: facts and fiction. *Phytochemistry*, *68* (22-24), 2986–3008.
- Fabricant, D. S., & Farnsworth, N. R. (2001). The value of plants used in traditional medicine for drug discovery. *Environmental Health Perspectives*, *109*, Suppl. 1, 69–75.
- Feliciano, R. P., Bravo, M. N., Pires, M. M., Serra, A. T., Duarte, C. M., Boas, L. V., & Bronze, M. R. (2008). Phenolic Content and Antioxidant Activity of Moscatel Dessert Wines from the Setúbal Region in Portugal. *Food Analytical Methods*, *2* (2), 149–161.
- Ferlay, J., Shin, H. R., Bray, F., Forman, D., Mathers, C. D., Parkin, D. M. (2012). International Agency for Research on Cancer. GLOBOCAN 2012: Estimated Cancer Incidence, Mortality and Prevalence Worldwide in 2012. Retrieved in January 6, 2014, from http://globocan.iarc.fr/Pages/fact_sheets_cancer.aspx
- Filip, S., Vidović, S., Adamović, D., & Zeković, Z. (2013). Fractionation of non-polar compounds of basil (*Ocimum basilicum* L.) by supercritical fluid extraction (SFE). *The Journal of Supercritical Fluids*, *86*, 85–90.
- Fismer, K. L., & Pilkington, K. (2012). Lavender and sleep: A systematic review of the evidence. *European Journal of Integrative Medicine*, *4* (4), e436–e447.

- Fornari, T., Vicente, G., Vázquez, E., García-Risco, M. R., & Reglero, G. (2012). Isolation of essential oil from different plants and herbs by supercritical fluid extraction. *Journal of Chromatography A*, *1250*, 34–48.
- Garlet, T. M. B., Paulus, D., & Flores, R. (2013). Production and chemical composition of *Mentha x piperita* var . *citrate* (Ehrh .) Briq essential oil regarding to different potassium concentrations in the hydroponic solution. *Journal of Biotechnology and Biodiversity*, *4*, 200–206.
- Giray, E. S., Kirici, S., Kaya, D. A., Türk, M., Sönmez, O., & Inan, M. (2008). Comparing the effect of sub-critical water extraction with conventional extraction methods on the chemical composition of *Lavandula stoechas*. *Talanta*, *74* (4), 930–5.
- Goldberg I. (1994). *Functional Foods: Designer Foods, Pharmafoods, Nutraceuticals*. New York: Chapman & Hall.
- Gonçalves, S., & Romano, A. (2013). In vitro culture of lavenders (*Lavandula* spp.) and the production of secondary metabolites. *Biotechnology Advances*, *31* (2), 166–74.
- Gotti, R. (2011). Capillary electrophoresis of phytochemical substances in herbal drugs and medicinal plants. *Journal of Pharmaceutical and Biomedical Analysis*, *55* (4), 775–801.
- Gould, M. N. (1995). Prevention and therapy of mammary cancer by monoterpenes. *Journal of Cellular Biochemistry. Suppl.* *22*, 139–44.
- Gould, M. N. (1997). Cancer chemoprevention and therapy by monoterpenes. *Environmental Health Perspectives*, *105*, *Suppl. 4*, 977–9.
- Greenlee, H. (2012). Natural products for cancer prevention. *Seminars in Oncology Nursing*, *28* (1), 29–44.
- Harborne, J. B.(1999). Classes and Functions of Secondary Products from Plants. In N. J., Walton, & D. E. Brown (Eds.). *Chemicals from Plants: Perspectives on Plant Secondary Products*. (pp.1–25) London: Imperial College Press.
- Hassan, S. B., Gali-Muhtasib, H., Göransson, H., & Larsson, R. (2010). Alpha terpineol: A potential anticancer agent which acts through suppressing NF-κB signalling. *Anticancer Research*, *30* (6), 1911–9.
- Hayashi, Y., Fukushima, S., Kishimoto, S., Kawguachi, T., Numata, M., Isoda, Y., Hirano, J., & Nakano, M. (1992). Anticancer Effects of Free Polyunsaturated Fatty Acids in an Oily Lymphographic Agent following Intrahepatic Arterial Administration to a Rabbit Bearing VX-2 Tumor. *Cancer Research*, *52*, 400–405.
- Herrero, M., Castro-Puyana, M., Mendiola, J. A., & Ibañez, E. (2013). Compressed fluids for the extraction of bioactive compounds. *Trends in Analytical Chemistry*, *43* (2), 67–83.
- Herrero, M., Cifuentes, A, & Ibanez, E. (2006). Sub- and supercritical fluid extraction of functional ingredients from different natural sources: Plants, food-by-products, algae and microalgae: A review. *Food Chemistry*, *98* (1), 136–148.
- Hitchcock, C.; Nichols, B. W. (1971). *Plant lipid biochemistry: The biochemistry of fatty acids and acyl lipids with particular reference to higher plants and algae*. Vol. 4. Academic Press.

- Hritcu, L., Cioanca, O., & Hancianu, M. (2012). Effects of lavender oil inhalation on improving scopolamine-induced spatial memory impairment in laboratory rats. *Phytomedicine*, *19* (6), 529–34.
- Hsu, C.-M., Yu, S.-C., Tsai, F.-J., & Tsai, Y. (2013). Enhancement of rhubarb extract solubility and bioactivity by 2-hydroxypropyl- β -cyclodextrin. *Carbohydrate Polymers*, *98* (2), 1422–9.
- Huang, D., Ou, B., Hampsch-Woodill, M., Flanagan, J. A., & Deemer, E. K. (2002). Development and validation of oxygen radical absorbance capacity assay for lipophilic antioxidants using randomly methylated β -cyclodextrin as the solubility enhancer. *Journal of Agricultural and Food Chemistry*, *50*(7), 1815–21.
- Huang, D., Ou, B., Hampsch-Woodill, M., Flanagan, J. A., & Prior, R. L. (2002). High-throughput assay of oxygen radical absorbance capacity (ORAC) using a multichannel liquid handling system coupled with a microplate fluorescence reader in 96-well format. *Journal of Agricultural and Food Chemistry*, *50*(16), 4437–44.
- Hussain, A. I., Anwar, F., Hussain Sherazi, S. T., & Przybylski, R. (2008). Chemical composition, antioxidant and antimicrobial activities of basil (*Ocimum basilicum*) essential oils depends on seasonal variations. *Food Chemistry*, *108* (3), 986–995.
- Ip, C., Banni, S., Angioni, E., Carta, G., Mcginley, J., Thompson, H. J., Barbano, D., & Bauman, D. (1999). Conjugated Linoleic Acid – Enriched Butter Fat Alters Mammary Gland Morphogenesis and Reduces Cancer Risk in Rats. *The Journal of Nutrition*, *129*, 2135–2142.
- Itani, W. S., El-banna, S. H., Hassan, S. B., Larsson, R. L., Bazarbachi, A., & Gali-Muhtasib, H. U. (2008). *Cancer Biology & Therapy*, *7* (11), 1765–1773.
- Jaafari, A., Tilaoui, M., Mouse, H. A., M'bark, L. A., Aboufatima, R., Chait, A., Lepoivre, M., & Ziad, A. (2012). Comparative study of the antitumor effect of natural monoterpenes: relationship to cell cycle analysis. *Brazilian Journal of Pharmacognosy*, *22* (3), 534–540.
- Jacobs, M.B. (1939). *The Chemical Analysis of Foods and Food Products*. 2nd printing. New York: D. Van Nostrand Company, Inc.
- Jayaprakasha, G. K., Murthy, K. N. C., Uckoo, R. M., & Patil, B. S. (2013). Chemical composition of volatile oil from *Citrus limettioides* and their inhibition of colon cancer cell proliferation. *Industrial Crops and Products*, *45*, 200–207.
- Kaefer, C. M., & Milner, J. A. (2008). The role of herbs and spices in cancer prevention. *The Journal of Nutritional Biochemistry*, *19* (6), 347–61.
- Kaliora, A. C., Kogiannou, D. A. A., Kefalas, P., Papassideri, I. S., & Kalogeropoulos, N. (2014). Phenolic profiles and antioxidant and anticarcinogenic activities of Greek herbal infusions; balancing delight and chemoprevention? *Food Chemistry*, *142*, 233–41.
- Kedia, A., Prakash, B., Mishra, P. K., Chanotiya, C. S., & Dubey, N. K. (2014). Antifungal, antiaflatoxigenic, and insecticidal efficacy of spearmint (*Mentha spicata* L.) essential oil. *International Biodeterioration & Biodegradation*, *89*, 29–36.
- Khanuja, S. P. S., Shasany, A. K., Srivastava, A., & Kumar, S. (2000). Assessment of genetic relationships in *Mentha* species. *Euphytica*, *111*, 121–125.

- Kim, D. J., Shin, D. H., Ahn, B., Kang, J. S., Nam, K. T., Park, C. B., Kim C. K., Hong, J. T., Kim, Y.-B., Yun, Y. W., Jang, D. D., & Yang, K.-H. (2003). Chemoprevention of colon cancer by Korean food plant components. *Mutation Research*, 523-524, 99–107.
- Kim, E., Coelho, D., & Blachier, F. (2013). Review of the association between meat consumption and risk of colorectal cancer. *Nutrition Research*, 33 (12), 983–94.
- King, M. B., & Bott, T. R. (1993). *Extraction of Natural Products Using Near-Critical Solvents*. Glasgow: Blackie Academic & Professional.
- Krzyzanowska, J., Czubacka, A., & Oleszek, W. (2010). Dietary Phytochemicals and Human Health. In M.T. Giardi, G. Rea, & B. Berra (Eds.). *Bio-Farms for Nutraceuticals: Functional Food and Safety Control by Biosensors*. (pp.74-98). Landes Bioscience and Springer Science+Business Media.
- Kumar, P., Mishra, S., Malik, A., & Satya, S. (2012). Efficacy of *Mentha × piperita* and *Mentha citrata* essential oils against housefly, *Musca domestica* L. *Industrial Crops and Products*, 39, 106–112.
- Kumazaki, M., Noguchi, S., Yasui, Y., Iwasaki, J., Shinohara, H., Yamada, N., & Akao, Y. (2013). Anti-cancer effects of naturally occurring compounds through modulation of signal transduction and miRNA expression in human colon cancer cells. *The Journal of Nutritional Biochemistry*, 24 (11), 1849–58.
- Lang, Q., & Wai, C. M. (2001). Supercritical fluid extraction in herbal and natural product studies – a practical review. *Talanta*, 53 (4), 771–82.
- Lawrence, B. M. (2007). *Mint: The genus Mentha*. Florida: CRC Press.
- Lee, C. H., Lee, Y.-W., Kim, J.-D., & Row, K. H. (2001). Separation of perillyl alcohol from the peel of citrus unshiu by supercritical CO₂ and preparative high-performance liquid chromatography. *Korean Journal of Chemical Engineering*, 18 (3), 352–356.
- Mahboubi, M., & Haghi, G. (2008). Antimicrobial activity and chemical composition of *Mentha pulegium* L. essential oil. *Journal of Ethnopharmacology*, 119 (2), 325–7.
- Mazzutti, S., Ferreira, S. R. S., Riehl, C. A. S., Smania, A., Smania, F. A., & Martínez, J. (2012). Supercritical fluid extraction of *Agaricus brasiliensis*: Antioxidant and antimicrobial activities. *The Journal of Supercritical Fluids*, 70, 48–56.
- Mehta, R. G., Murillo, G., Naithani, R., & Peng, X. (2010). Cancer chemoprevention by natural products: how far have we come? *Pharmaceutical Research*, 27, 950–961.
- Moore, J., Yin, J.-J., & Yu, L. L. (2006). Novel fluorometric assay for hydroxyl radical scavenging capacity (HOOSC) estimation. *Journal of Agricultural and Food Chemistry*, 54 (3), 617–26.
- Mukhopadhyay, M. (2000). *Natural Extracts Using Supercritical Carbon Dioxide*. Florida: CRC Press.
- Nanekarani, S., Goodarzi, M., Heidari, M., & Landy, N. (2012). Efficiency of ethanolic extract of peppermint (*Mentha piperita*) as an antibiotic growth promoter substitution on performance, and carcass characteristics in broiler chickens. *Asian Pacific Journal of Tropical Biomedicine*, 2 (3), S1611–S1614.

NCI, National Cancer Institute (2006). What You Need To Know About Cancer of the Colon and Rectum.

Retrieved in January 6, 2014, from

<http://www.cancer.gov/cancertopics/wyntk/colon-and-rectal/page2>

Neergheen, V. S., Bahorun, T., Taylor, E. W., Jen, L.-S., & Aruoma, O. I. (2010). Targeting specific cell signaling transduction pathways by dietary and medicinal phytochemicals in cancer chemoprevention. *Toxicology*, 278 (2), 229–41.

Nibret, E., & Wink, M. (2010). Trypanocidal and antileukaemic effects of the essential oils of *Hagenia abyssinica*, *Leonotis ocymifolia*, *Moringa stenopetala*, and their main individual constituents. *Phytomedicine*, 17 (12), 911–20.

Nobre, B. P., Palavra, A. F., Pessoa, F. L. P., & Mendes, R. L. (2009). Supercritical CO₂ extraction of *trans*-lycopene from Portuguese tomato industrial waste. *Food Chemistry*, 116 (3), 680–685.

Ortega-Ramirez, L. A., Rodriguez-Garcia, I., Leyva, J. M., Cruz-Valenzuela, M. R., Silva-Espinoza, B. A., Gonzalez-Aguilar, G. A., Siddiqui, M. W., Ayala-Zavala, J. F. (2014). Potential of medicinal plants as antimicrobial and antioxidant agents in food industry: a hypothesis. *Journal of Food Science*, 79 (2), R129–37.

Ou, B., Hampsch-Woodill, M., Flanagan, J., Deemer, E. K., Prior, R. L., & Huang, D. (2002). Novel fluorometric assay for hydroxyl radical prevention capacity using fluorescein as the probe. *Journal of Agricultural and Food Chemistry*, 50 (10), 2772–7.

Palmer, M. V., & Ting, S. S. T. (1995). Applications for supercritical fluid technology in food processing. *Food Chemistry*, 52 (4), 345–352.

Patil, B. S., Jayaprakasha, G. K., Chidambara Murthy, K. N., & Vikram A. (2009). Bioactive Compounds: Historical Perspectives, Opportunities, and Challenges. *Journal of Agricultural and Food Chemistry*, 57, 8142–8160.

Perrut, M. (2000). Supercritical Fluid Applications: Industrial Developments and Economic Issues. *Industrial & Engineering Chemistry Research*, 39 (12), 4531–4535.

Platt, E. S. (2009). *Lavender: How to Grow and Use the Fragrant Herb*. 2nd edition. Mechanicsburg, PA: Stackpole Books.

Pourmortazavi, S. M., & Hajimirsadeghi, S. S. (2007). Supercritical fluid extraction in plant essential and volatile oil analysis. *Journal of Chromatography. A*, 1163 (1-2), 2–24.

Rafter, J. J. (2002). Scientific basis of biomarkers and benefits of functional foods for reduction of disease risk: cancer. *British Journal of Nutrition*, 88, Suppl. 2, 219–224.

Raisi Dehkordi, Z., Hosseini Baharanchi, F. S., & Bekhradi, R. (2014). Effect of lavender inhalation on the symptoms of primary dysmenorrhea and the amount of menstrual bleeding: A randomized clinical trial. *Complementary Therapies in Medicine*.

Raskin, I., Ribnicky, D. M., Komarnytsky, S., Ilic, N., Poulev, A., Borisjuk, N., Brinker, A., Moreno, D. A., Ripoll, C., Yakoby, N., O'Neal, J. M., Cornwell, T., Pastor, I., & Fridlender, B. (2002). Plants and human health in the twenty-first century. *Trends in Biotechnology*, 20 (12), 522–31.

- Reverchon, E. (1997). Supercritical fluid extraction and fractionation related products. *The Journal of Supercritical Fluids*, 10, 1–37.
- Reverchon, E., & De Marco, I. (2006). Supercritical fluid extraction and fractionation of natural matter. *The Journal of Supercritical Fluids*, 38 (2), 146–166.
- Riahi, L., Elferchichi, M., Ghazghazi, H., Jebali, J., Ziadi, S., Aouadhi, C., Chogranif, H., Zaoualif, Y., Zoghلامي, N., & Mliki, A. (2013). Phytochemistry, antioxidant and antimicrobial activities of the essential oils of *Mentha rotundifolia* L. in Tunisia. *Industrial Crops and Products*, 49, 883–889.
- Ricchi, M., Odoardi, M. R., Carulli, L., Anzivino, C., Ballestri, S., Pinetti, A., Fantoni, L. I., Marra, F., Bertolotti, M., Banni, S., Lonardo, A., Carulli, N., & Loria, P. (2009). Differential effect of oleic and palmitic acid on lipid accumulation and apoptosis in cultured hepatocytes. *Journal of Gastroenterology and Hepatology*, 24 (5), 830–40.
- Richard, D., Kefi, K., Barbe, U., Bausero, P., & Visioli, F. (2008). Polyunsaturated fatty acids as antioxidants. *Pharmacological Research*, 57 (6), 451–5.
- Ruberto, G., & Baratta, M. T. (2000). Antioxidant activity of selected essential oil components in two lipid model systems. *Food Chemistry*, 69 (2), 167–174.
- Rubio, C., Lucas, J. R. D., Gutiérrez, a J., Glez-Weller, D., Pérez Marrero, B., Caballero, J. M., Revert, C., & Hardisson, A. (2012). Evaluation of metal concentrations in mentha herbal teas (*Mentha piperita*, *Mentha pulegium* and *Mentha species*) by inductively coupled plasma spectrometry. *Journal of pharmaceutical and biomedical analysis*, 71, 11–7.
- Sahena, F., Zaidul, I. S. M., Jinap, S., Karim, A. A., Abbas, K. A., Norulaini, N. A. N., & Omar, A. K. M. (2009). Application of supercritical CO₂ in lipid extraction – A review. *Journal of Food Engineering*, 95 (2), 240–253.
- Sambuy, Y., De Angelis, I., Ranaldi, G., Scarino, M. L., Stamatii, A., & Zucco, F. (2005). The Caco-2 cell line as a model of the intestinal barrier: influence of cell and culture-related factors on Caco-2 cell functional characteristics. *Cell Biology and Toxicology*, 21 (1), 1–26.
- Sánchez-Camargo, A. P., Meireles, M. A. A., Ferreira, A. L. K., Saito, E., & Cabral, F. A. (2012). Extraction of ω-3 fatty acids and astaxanthin from Brazilian redspotted shrimp waste using supercritical CO₂+ethanol mixtures. *The Journal of Supercritical Fluids*, 61, 71–77.
- Sánchez-González, L., Vargas, M., González-Martínez, C., Chiralt, A., & Cháfer, M. (2011). Use of Essential Oils in Bioactive Edible Coatings: A Review. *Food Engineering Reviews*, 3 (1), 1–16.
- Santana, A., Jesus, S., Larrayoz, M. A., & Filho, R. M. (2012). Supercritical Carbon Dioxide Extraction of Algal Lipids for the Biodiesel Production. *Procedia Engineering*, 42, 1755–1761.
- Serra, A. T. (2010). Valorization of traditional Portuguese apples and cherries. Biochemical characterization and development of functional ingredients. (PhD thesis).
- Serra, A. T., Poejo, J., Matias, A. A., Bronze, M. R., & Duarte, C. M. M. (2013). Evaluation of *Opuntia* spp. derived products as antiproliferative agents in human colon cancer cell line (HT29). *Food Research International*, 54 (1), 892–901.

- Shahidi, F. (2009). Nutraceuticals and functional foods: whole versus processed foods. *Trends in Food Science & Technology*, 20 (9), 376–387.
- Shehzad, A., Wahid, F., & Lee, Y. S. (2010). Curcumin in cancer chemoprevention: molecular targets, pharmacokinetics, bioavailability, and clinical trials. *Archiv Der Pharmazie*, 343 (9), 489–99.
- Shilpi, A., Shivhare, U. S., & Basu, S. (2013). Supercritical CO₂ Extraction of Compounds with Antioxidant Activity from Fruits and Vegetables Waste – A Review. Focusing on Modern Food Industry, 2 (1), 43–62.
- Sihvonen, M., Järvenpää, E., Hietniemi, V., & Huopalahti, R. (1999). Advances in supercritical carbon dioxide technologies. *Trends in Food Science & Technology*, 10, 217–222.
- Sun, M., & Temelli, F. (2006). Supercritical carbon dioxide extraction of carotenoids from carrot using canola oil as a continuous co-solvent. *The Journal of Supercritical Fluids*, 37 (3), 397–408.
- Sundin, T., Peffley, D. M., Gauthier, D., & Hentosh, P. (2012). The isoprenoid perillyl alcohol inhibits telomerase activity in prostate cancer cells. *Biochimie*, 94 (12), 2639–48.
- Talpur, A. D. (2014). *Mentha piperita* (Peppermint) as feed additive enhanced growth performance, survival, immune response and disease resistance of Asian seabass, *Lates calcarifer* (Bloch) against *Vibrio harveyi* infection. *Aquaculture*, 420-421, 71–78.
- Tatman, D., & Mo, H. (2002). Volatile isoprenoid constituents of fruits, vegetables and herbs cumulatively suppress the proliferation of murine B16 melanoma and human HL-60 leukemia cells. *Cancer Letters*, 175 (2), 129–39.
- Tavakoli, R., Mohadjerani, M., Hosseinzadeh, R., Tajbakhsh, M., & Naqinezhad, A. (2012). Essential-oil and fatty-acid composition, and antioxidant activity of extracts of *Ficaria kochii*. *Chemistry & Biodiversity*, 9 (12), 2732–41.
- Teixeira, B., Marques, A., Ramos, C., Batista, I., Serrano, C., Matos, O., Neng, N. R., Nogueira, J. M. F., Saraiva, J. A., & Nunes, M. L. (2012). European pennyroyal (*Mentha pulegium*) from Portugal: Chemical composition of essential oil and antioxidant and antimicrobial properties of extracts and essential oil. *Industrial Crops and Products*, 36 (1), 81–87.
- Telci, I., Demirtas, I., Bayram, E., Arabaci, O., & Kacar, O. (2010). Environmental variation on aroma components of pulegone/piperitone rich spearmint (*Mentha spicata* L.). *Industrial Crops and Products*, 32 (3), 588–592.
- Tepe, B., Daferera, D., Tepe, A.-S., Polissiou, M., & Sokmen, A. (2007). Antioxidant activity of the essential oil and various extracts of *Nepeta flavida* Hub.-Mor. from Turkey. *Food Chemistry*, 103 (4), 1358–1364.
- Tepe, B., Donmez, E., Unlu, M., Candan, F., Daferera, D., Vardar-Unlu, G., Polissiu, M., & Sokmen, A. (2004). Antimicrobial and antioxidative activities of the essential oils and methanol extracts of *Salvia cryptantha* (Montbret et Aucher ex Benth.) and *Salvia multicaulis* (Vahl). *Food Chemistry*, 84 (4), 519–525.
- Tikekar, R. V., Ludescher, R. D., & Karwe, M. V. (2008). Processing Stability of Squalene in Amaranth and Antioxidant Potential of Amaranth Extract. *Journal of Agricultural and Food Chemistry*, 56 (22), 10675–8.

Tvrzicka, E., Kremmyda, L.-S., Stankova, B., & Zak, A. (2011). Fatty acids as biocompounds: their role in human metabolism, health and disease – a review. Part 1: classification, dietary sources and biological functions. *Biomedical Papers*, 155 (2), 117–130.

Vakili, A., Sharifat, S., Akhavan, M. M., & Bandegi, A. R. (2014). Effect of lavender oil (*Lavandula angustifolia*) on cerebral edema and its possible mechanisms in an experimental model of stroke. *Brain Research*, 1548, 56–62.

Vardar-Ünlü, G., Candan, F., Sökmen, A., Daferera, D., Polissiou, M., Sökmen, M., Dönmez, E., & Tepe, B. (2003). Antimicrobial and antioxidant activity of the essential oil and methanol extracts of *Thymus pectinatus* Fisch. et Mey. Var. *pectinatus* (Lamiaceae). *Journal of Agricultural and Food Chemistry*, 51 (1), 63–7.

Voirin, B., Bayet, C., Faure, O., & Jullien F. (1999) Free flavonoid aglycones as markers of parentage in *Mentha aquatic*, *M. citrata*, *M. spicata* and *M. x piperita*. *Phytochemistry*, 50, 1189–1193.

Wagner, H. & Bladt, S. (2001). Plant Drug Analysis – A Thin Layer Chromatography Atlas. 2nd edition. New York: Springer-Verlag.

Wang, L., & Weller, C. L. (2006). Recent advances in extraction of nutraceuticals from plants. *Trends in Food Science & Technology*, 17 (6), 300–312.

Waters (2010). Supercritical Fluid Extraction Systems

WCRF / AICR, World Cancer Research Fund / American Institute for Cancer Research (2007). Food, Nutrition, Physical Activity, and the Prevention of Cancer: a Global Perspective.

World Health Organization (2014). Fact Sheet on Cancer.
Retrieved in January 6, 2014, from
<http://www.who.int/mediacentre/factsheets/fs297/en/>

Yang, M. H., Kim, J., Khan, I. a., Walker, L. a., & Khan, S. I. (2014). Nonsteroidal anti-inflammatory drug activated gene-1 (NAG-1) modulators from natural products as anti-cancer agents. *Life Sciences*.

Yoo, Y.-C., Shin, B.-H., Hong, J.-H., Lee, J., Chee, H.-Y., Song, K.-S., & Lee, K.-B. (2007). Isolation of fatty acids with anticancer activity from *Protaetia brevitarsis* larva. *Archives of Pharmacal Research*, 30 (3), 361–5.

Yoshida, N., Takada, T., Yamamura, Y. Adachi, I., Suzuki, H., & Kawakami, J. (2008). Inhibitory Effects of Terpenoids on Multidrug Resistance-Associated Protein 2- and Breast Cancer Resistance Protein-Mediated Transport. *Drug Metabolism and Disposition*, 36 (7), 1206–1211.

Zhao, D., Xu, Y. W., Yang, G. L., Husaini, A. M., & Wu, W. (2013). Variation of essential oil of *Mentha haplocalyx* Briq. and *Mentha spicata* L. from China. *Industrial Crops and Products*, 42, 251–260.

Zhou, S., Koh, H., Gao, Y., Gong, Z., Jon, E., & Lee, D. (2004). Herbal bioactivation : The good, the bad and the ugly. *Life Sciences*, 74, 935–968.

Ziech, D., Anastopoulos, I., Hanafi, R., Voulgaridou, G. P., Franco, R., Georgakilas, A. G., Pappa, A., & Panayiotidis, M. I. (2012). Pleiotrophic effects of natural products in ROS-induced carcinogenesis: the role of plant-derived natural products in oral cancer chemoprevention. *Cancer Letters*, 327 (1-2), 16–25.

Zitka, O., Sochor, J., Rop, O., Skalickova, S., Sobrova, P., Zehnalek, J., Beklova, M., Krska, B., Adam, V. & Kizek, R. (2011). Comparison of various easy-to-use procedures for extraction of phenols from apricot fruits. *Molecules*, 16 (4), 2914–36.

Zuzarte, M., Gonçalves, M. J., Cavaleiro, C., Cruz, M. T., Benzarti, A., Marongiu, B., Maxia, A., Piras, A., & Salgueiro, L. (2013). Antifungal and anti-inflammatory potential of *Lavandula stoechas* and *Thymus herba-barona* essential oils. *Industrial Crops and Products*, 44, 97–103.

6. Appendix

Appendix A – Thin Layer Chromatography

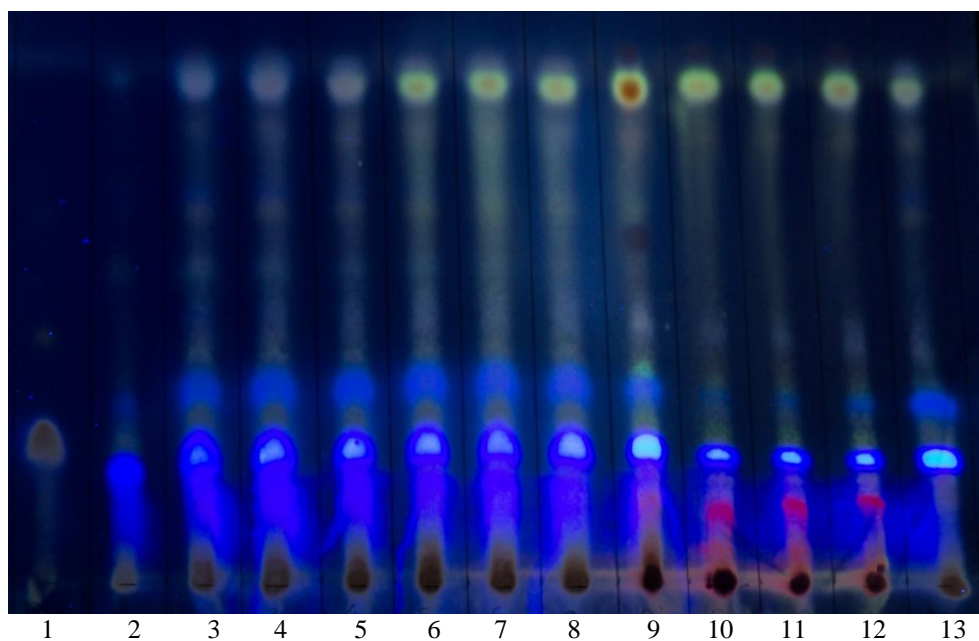

Figure 6.1 TLC analysis of the *L. angustifolia* extract, obtained by SFE, to reveal terpenes and steroids. Legend: 1 – perillyl alcohol standard; 2 – 1st fraction (0 – 60 min; 2nd fraction collector); 3 – 1st fraction (0 – 30 min; 1st fraction collector); 4 – 2nd fraction (30 – 60 min; 1st fraction collector); 5 – 2nd fraction (60 – 180 min; 2nd fraction collector); 6 – 3rd fraction (60 – 90 min; 1st fraction collector); 7 – 4th fraction (90 – 120 min; 1st fraction collector); 8 – 5th fraction (120 – 150 min; 1st fraction collector); 9 – 6th fraction (150 – 180 min; 1st fraction collector); 10 – 7th fraction (180 – 210 min; 1st fraction collector); 11 – 8th fraction (210 – 240 min; 1st fraction collector); 12 – Depressurization / Cleaning (1st fraction collector); 13 – Depressurization / Cleaning (2nd fraction collector).

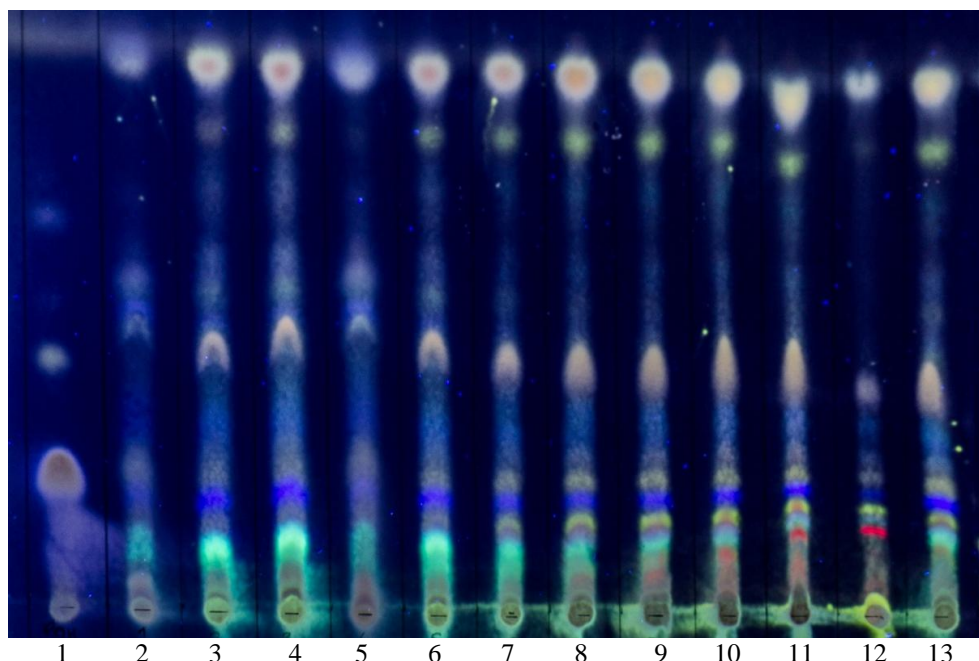

Figure 6.2 TLC analysis of the *L. stoechas* extract, obtained by SFE, to reveal terpenes and steroids.
 Legend: 1 – perillyl alcohol standard; 2 – 1st fraction (0 – 60 min; 2nd fraction collector); 3 – 1st fraction (0 – 30 min; 1st fraction collector); 4 – 2nd fraction (30 – 60 min; 1st fraction collector); 5 – 2nd fraction (60 – 180 min; 2nd fraction collector); 6 – 3rd fraction (60 – 90 min; 1st fraction collector); 7 – 4th fraction (90 – 120 min; 1st fraction collector); 8 – 5th fraction (120 – 150 min; 1st fraction collector); 9 – 6th fraction (150 – 180 min; 1st fraction collector); 10 – 7th fraction (180 – 210 min; 1st fraction collector); 11 – 8th fraction (210 – 240 min; 1st fraction collector); 12 – Depressurization / Cleaning (1st fraction collector); 13 – Depressurization / Cleaning (2nd fraction collector).

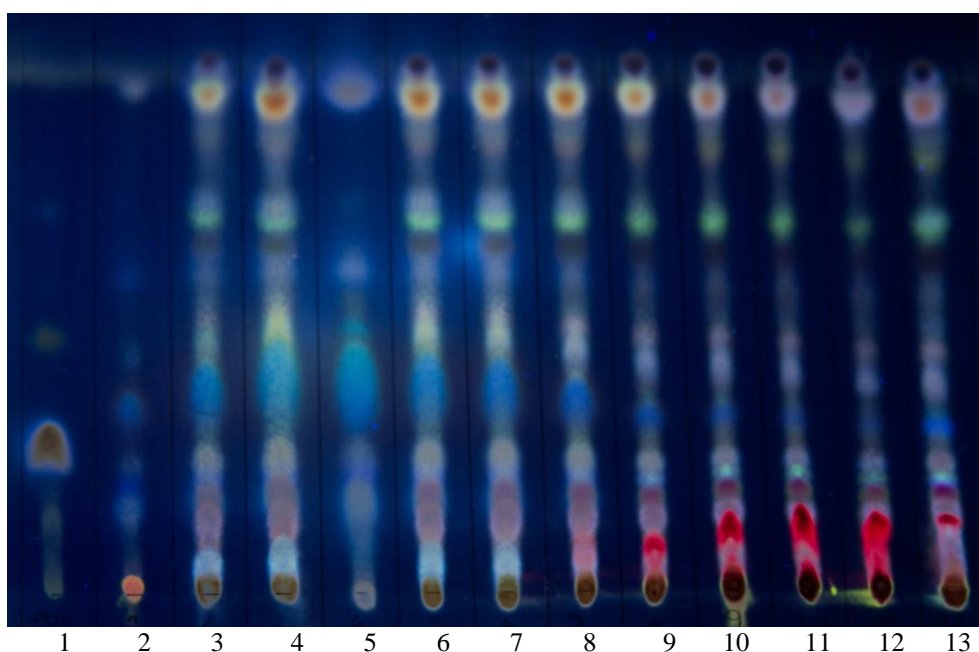

Figure 6.3 TLC analysis of the *M. spicata* extract, obtained by SFE, to reveal terpenes and steroids.
 Legend: 1 – perillyl alcohol standard; 2 – 1st fraction (0 – 60 min; 2nd fraction collector); 3 – 1st fraction (0 – 30 min; 1st fraction collector); 4 – 2nd fraction (30 – 60 min; 1st fraction collector); 5 – 2nd fraction (60 – 180 min; 2nd fraction collector); 6 – 3rd fraction (60 – 90 min; 1st fraction collector); 7 – 4th fraction (90 – 120 min; 1st fraction collector); 8 – 5th fraction (120 – 150 min; 1st fraction collector); 9 – 6th fraction (150 – 180 min; 1st fraction collector); 10 – 7th fraction (180 – 210 min; 1st fraction collector); 11 – 8th fraction (210 – 240 min; 1st fraction collector); 12 – Depressurization / Cleaning (1st fraction collector); 13 – Depressurization / Cleaning (2nd fraction collector).

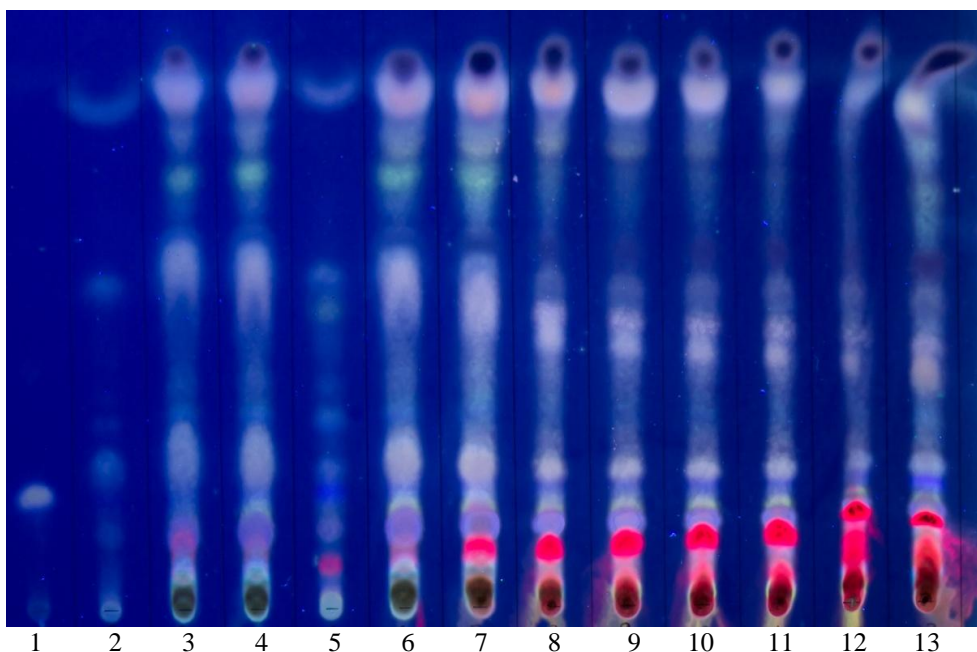

Figure 6.4 TLC analysis of the *M. piperita* var. *citrata* extract, obtained by SFE, to reveal terpenes and steroids. Legend: 1 – perillyl alcohol standard; 2 – 1st fraction (0 – 60 min; 2nd fraction collector); 3 – 1st fraction (0 – 30 min; 1st fraction collector); 4 – 2nd fraction (30 – 60 min; 1st fraction collector); 5 – 2nd fraction (60 – 180 min; 2nd fraction collector); 6 – 3rd fraction (60 – 90 min; 1st fraction collector); 7 – 4th fraction (90 – 120 min; 1st fraction collector); 8 – 5th fraction (120 – 150 min; 1st fraction collector); 9 – 6th fraction (150 – 180 min; 1st fraction collector); 10 – 7th fraction (180 – 210 min; 1st fraction collector); 11 – 8th fraction (210 – 240 min; 1st fraction collector); 12 – Depressurization / Cleaning (1st fraction collector); 13 – Depressurization / Cleaning (2nd fraction collector).

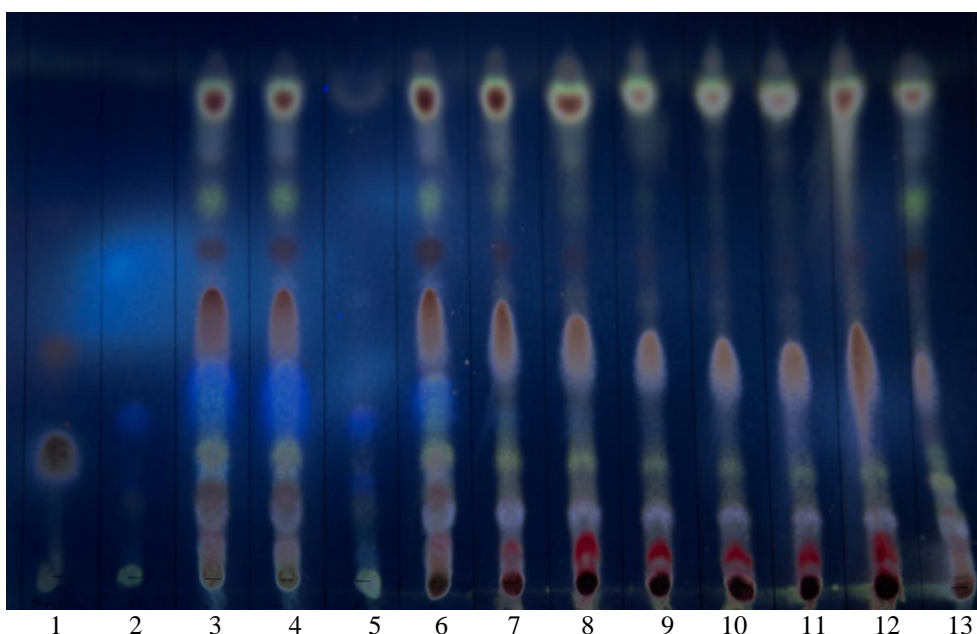

Figure 6.5 TLC analysis of the *M. pulegium* extract, obtained by SFE, to reveal terpenes and steroids. Legend: 1 – perillyl alcohol standard; 2 – 1st fraction (0 – 60 min; 2nd fraction collector); 3 – 1st fraction (0 – 30 min; 1st fraction collector); 4 – 2nd fraction (30 – 60 min; 1st fraction collector); 5 – 2nd fraction (60 – 180 min; 2nd fraction collector); 6 – 3rd fraction (60 – 90 min; 1st fraction collector); 7 – 4th fraction (90 – 120 min; 1st fraction collector); 8 – 5th fraction (120 – 150 min; 1st fraction collector); 9 – 6th fraction (150 – 180 min; 1st fraction collector); 10 – 7th fraction (180 – 210 min; 1st fraction collector); 11 – 8th fraction (210 – 240 min; 1st fraction collector); 12 – Depressurization / Cleaning (1st fraction collector); 13 – Depressurization / Cleaning (2nd fraction collector).

Appendix B – GC chromatograms

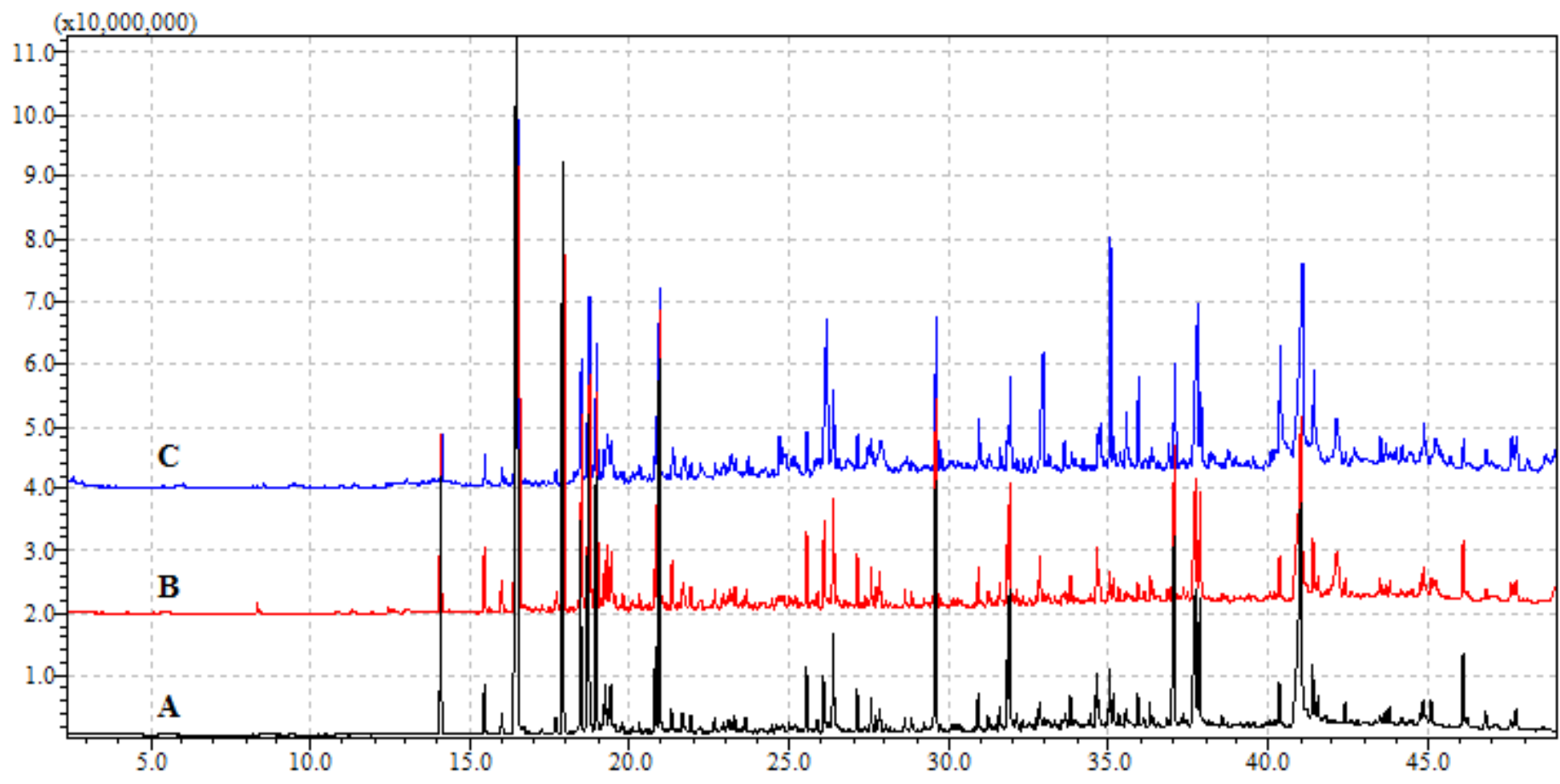

Figure 6.6 Chromatograms of the fractions of fresh extract of *L. angustifolia*. Legend: A – Fraction A; B – Fraction B; C – Fraction C.

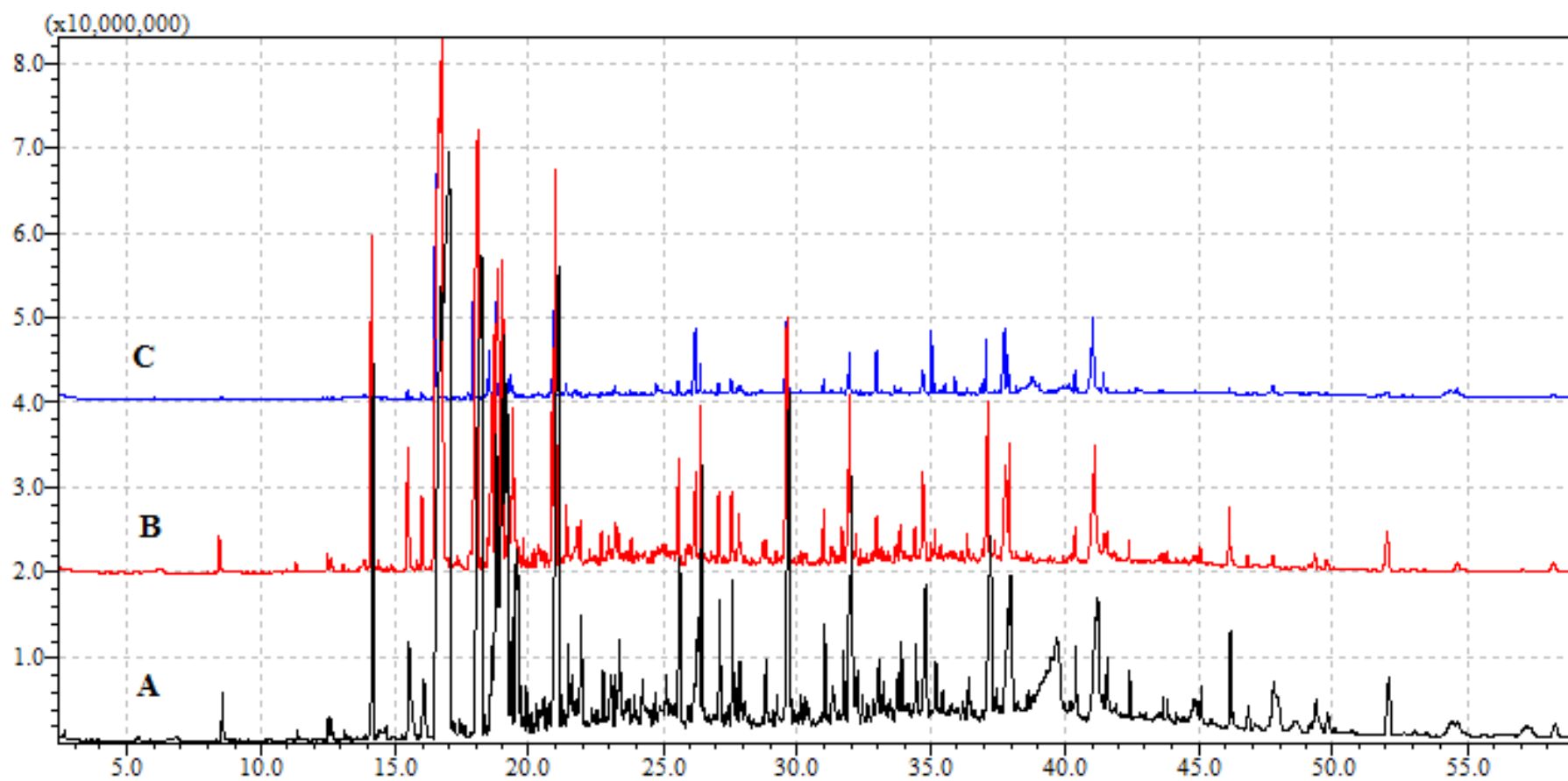

Figure 6.7 Chromatograms of the fractions of the not fresh extract of *L. angustifolia*. Legend: A – Fraction A; B – Fraction B; C – Fraction C.

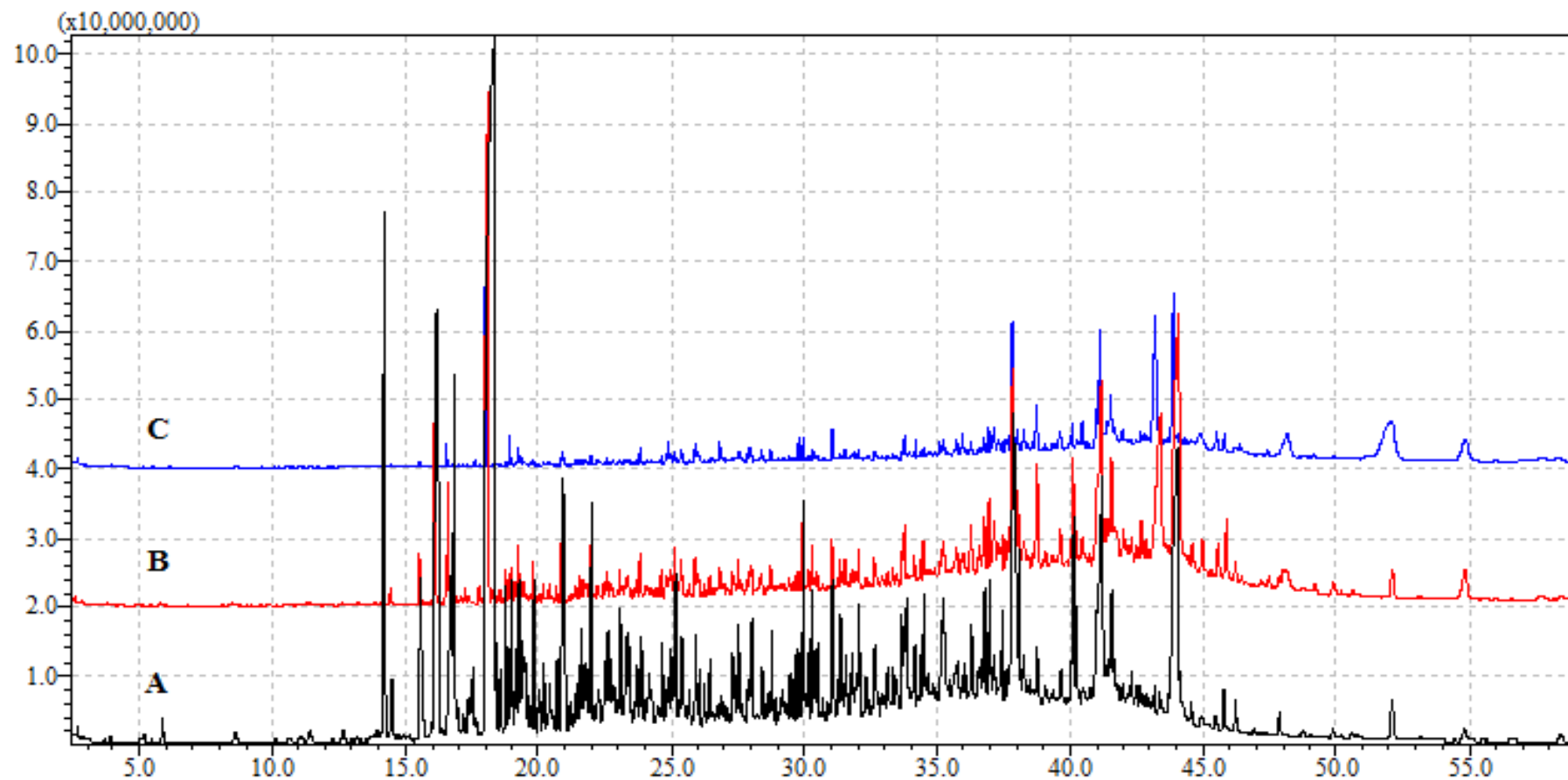

Figure 6.8 Chromatograms of the fractions of the extract of *L. stoechas*. Legend: A – Fraction A; B – Fraction B; C – Fraction C.

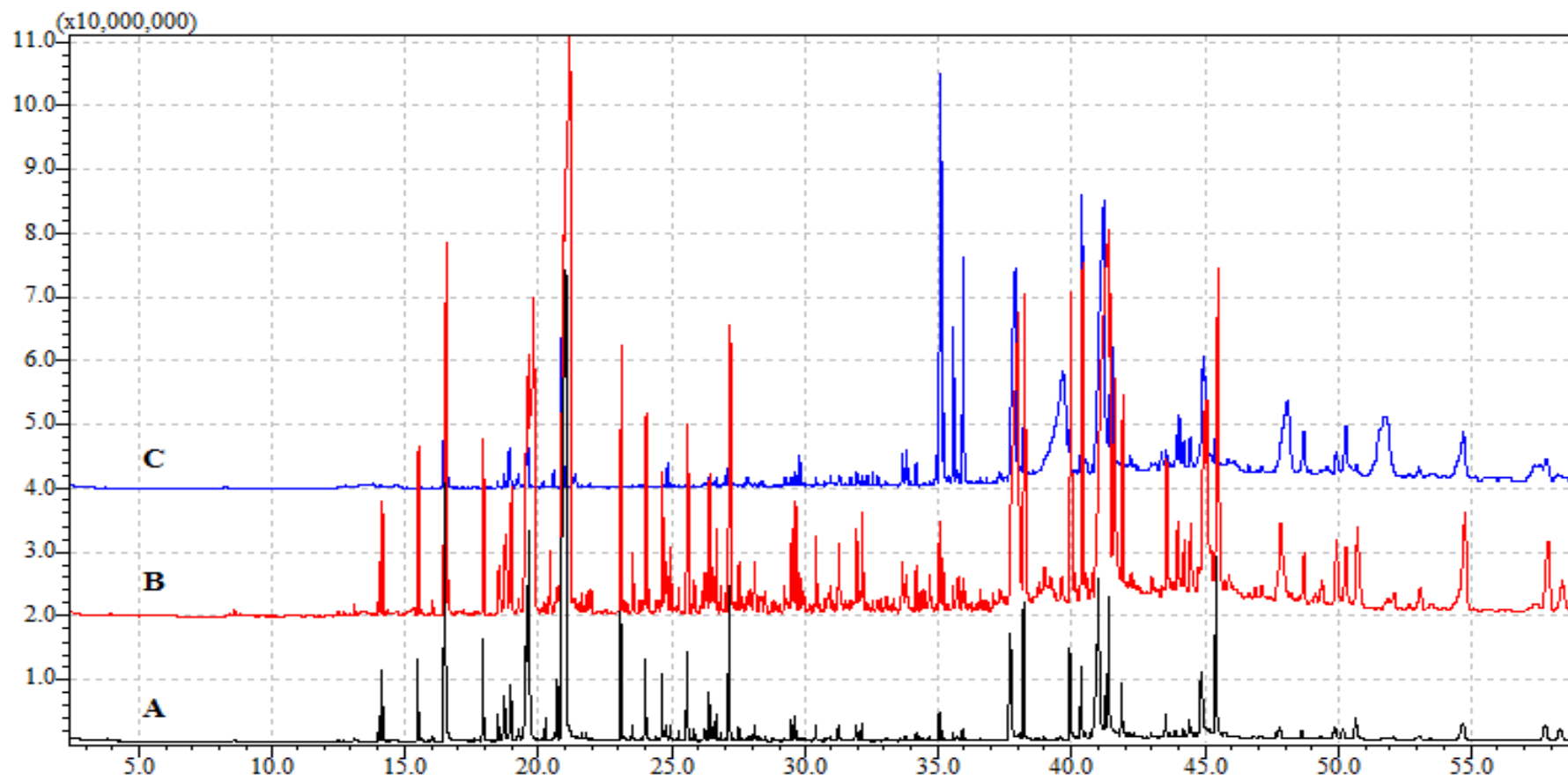

Figure 6.9 Chromatograms of the fractions of the extract of *M. spicata*. Legend: A – Fraction A; B – Fraction B; C – Fraction C.

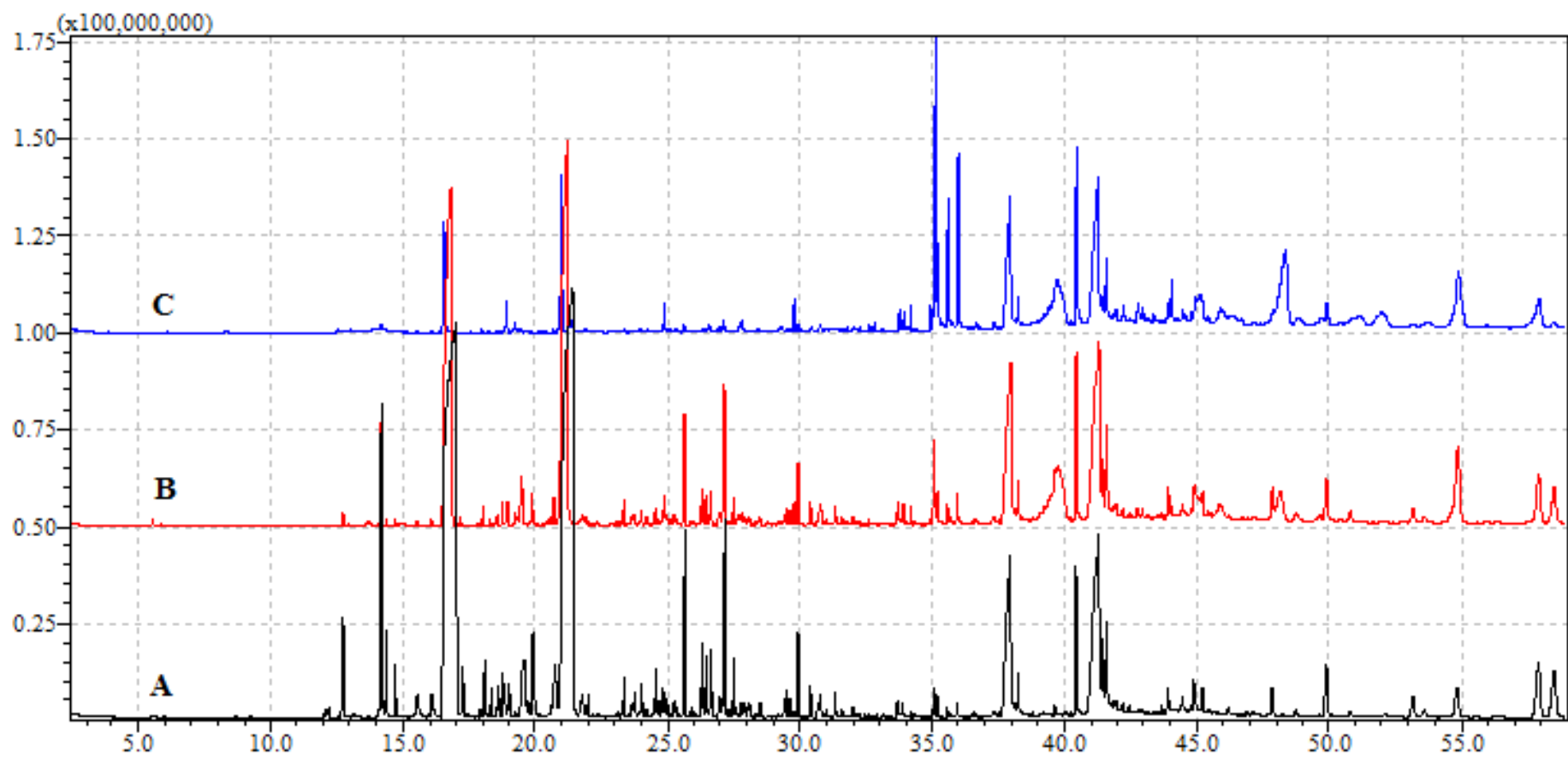

Figure 6.10 Chromatograms of the fractions of the extract of *M. piperita* var. *citrate*. Legend: A – Fraction A; B – Fraction B; C – Fraction C.

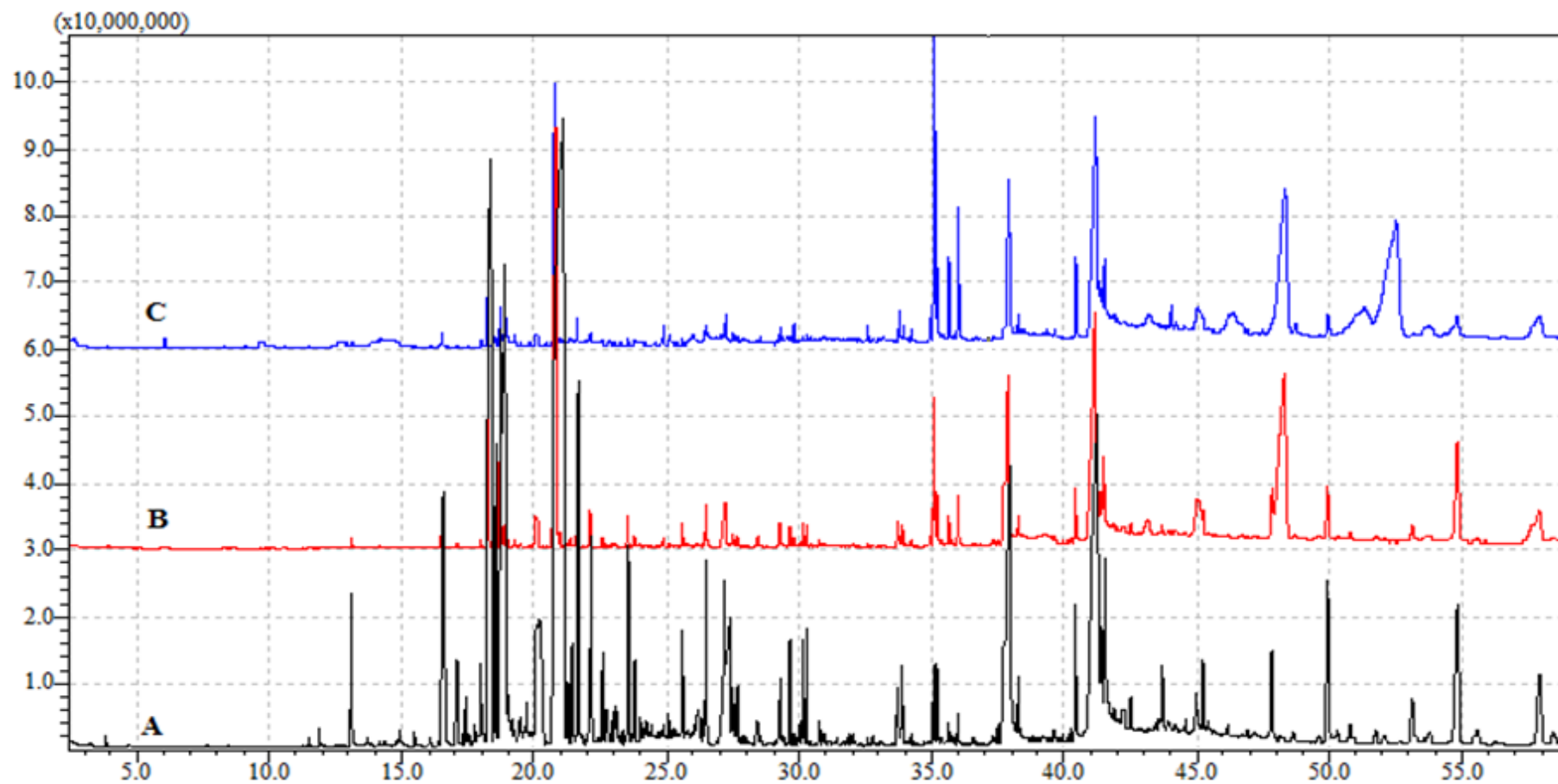

Figure 6.11 Chromatograms of the fractions of the extract of *M. pulegium*. Legend: A – Fraction A; B – Fraction B; C – Fraction.

